



**TRANE®**

# Installation Operation Maintenance

---

## Series R Helical Rotary Liquid Chillers



Models RTHD  
175-450 ton units (60 Hz)  
125-450 ton units (50 Hz)

---

November 2006

RTHD-SVX01D-EN



**NOTICE:** Warnings and Cautions appear at appropriate sections throughout this literature. Read these carefully.

**⚠ WARNING:** Indicates a potentially hazardous situation which, if not avoided, could result in death or serious injury.

**⚠ CAUTION:** Indicates a potentially hazardous situation which, if not avoided, may result in minor or moderate injury. It may also be used to alert against unsafe practices.

**CAUTION:** Indicates a situation that may result in equipment or property-damage only accidents.

## **Important Environmental Concerns!**

**Scientific research has shown that certain man-made chemicals can affect the earth's naturally occurring stratospheric ozone layer when released to the atmosphere. In particular, several of the identified chemicals that may affect the ozone layer are refrigerants that contain Chlorine, Fluorine and Carbon (CFCs) and those containing Hydrogen, Chlorine, Fluorine and Carbon (HCFCs). Not all refrigerants containing these compounds have the same potential impact to the environment. Trane advocates the responsible handling of all refrigerants—including industry replacements for CFCs such as and HCFCs and HFCs.**

## **Responsible Refrigerant Practices!**

**Trane believes that responsible refrigerant practices are important to the environment, our customers, and the air conditioning industry. All technicians who handle refrigerants must be certified. The Federal Clean Air Act (Section 608) sets forth the requirements for handling, reclaiming, recovering and recycling of certain refrigerants and the equipment that is used in these service procedures. In addition, some states or municipalities may have additional requirements that must also be adhered to for responsible management of refrigerants. Know the applicable laws and follow them.**

## **⚠ WARNING Contains Refrigerant!**

**System contains oil and refrigerant under high pressure. Recover refrigerant to relieve pressure before opening the system. See unit nameplate for refrigerant type. Do not use non-approved refrigerants, refrigerant substitutes, or refrigerant additives.**

**Failure to follow proper procedures or the use of non-approved refrigerants, refrigerant substitutes, or refrigerant additives could result in death or serious injury or equipment damage.**



# Table of Contents

<b>General Information.....</b>	<b>5</b>
Literature Change History .....	5
Unit Identification - Nameplates .....	5
Unit Inspection .....	6
Inspection Checklist .....	6
Loose Parts Inventory .....	6
Unit Description.....	6
Model Number Coding System.....	7
<b>Unit Model Number .....</b>	<b>7</b>
Installation Overview .....	12
<b>Installation Mechanical.....</b>	<b>19</b>
Storage .....	19
Location Requirements .....	19
Moving and Rigging.....	21
Lifting Procedure .....	25
Isolation Pads .....	29
Unit Leveling .....	30
Water Piping.....	31
Water Pressure Drop Data .....	39
Condenser Water Regulating Valve.....	49
Water Treatment.....	50
Water Pressure Gauges and Thermometers.....	51
Water Pressure Relief Valves.....	51
Flow Sensing Devices .....	51
Refrigerant Pressure Relief Valve Venting .....	52
Thermal Insulation .....	54
<b>Installation Electrical .....</b>	<b>57</b>
General Recommendations.....	57
Power Supply Wiring.....	57
Compressor Motor Phase Sequencing .....	59
Correcting Improper Electrical Phase Sequence .....	60
Application Of Solid-State Starters .....	63
Module Connections for Interconnecting Wiring .....	66
Interconnecting Wiring (Field Wiring Required).....	66
<b>Operating Principles Mechanical .....</b>	<b>75</b>
General .....	75
Refrigeration (Cooling) Cycle .....	75
Compressor Description.....	78
Oil Management System .....	80
Oil Cooler.....	82
<b>Operator Interface Controls .....</b>	<b>83</b>
CH530 Communications Overview .....	83
Controls Interface.....	83
DynaView Interface .....	84
Display Screens.....	85
Keypad/Display Lockout Feature .....	86
Main Screen .....	87
Reports Screen.....	92



# Table of Contents

---

Settings Screen .....	94
Diagnostic Screen .....	96
<b>TechView .....</b>	<b>97</b>
Minimum PC requirements to install and operate TechView .....	98
Unit View .....	99
Status View .....	100
Setpoint View .....	103
Manual Override View .....	107
Diagnostics View .....	109
Software View .....	113
Binding View .....	114
Software Download .....	115
<b>Unit Start-up .....</b>	<b>117</b>
Power Up .....	117
Power Up to Starting .....	117
Stopped to Starting: .....	119
Seasonal Unit Start-Up Procedure .....	121
<b>Unit Shutdown .....</b>	<b>125</b>
Normal Shutdown to Stopped .....	125
Seasonal Unit Shutdown .....	126
<b>Periodic Maintenance .....</b>	<b>127</b>
Overview .....	127
Weekly Maintenance and Checks .....	127
Monthly Maintenance and Checks .....	127
Annual Maintenance .....	128
Scheduling Other Maintenance .....	129
<b>Maintenance Procedures .....</b>	<b>133</b>
Cleaning the Condenser .....	133
Mechanical Cleaning Procedure .....	133
Chemical Cleaning Procedure .....	136
Cleaning the Evaporator .....	137
Compressor Oil .....	137
Oil Sump Level Check .....	137
Removing Compressor Oil .....	139
Oil Charging Procedure .....	139
Replacing the Main Oil Filter (Hot Filter) .....	140
Replacing the Gas Pump Oil Filter .....	141
Refrigerant Charge .....	141
Refrigerant Charging .....	142
<b>Diagnostics .....</b>	<b>145</b>
<b>Wiring Schematics .....</b>	<b>159</b>
Unit Electrical Data .....	159

# General Information

## Literature Change History

RTHD-SVX01D-EN Additional configurations available for 50 hz units. (Nov. 2006)

RTHD-SVX01C-EN New control panel design. (May 2005)

RTHD-SVX01B-EN New Evap/Cond configuration C2F2F3 and change to minimum flow rates. (June 2004)

RTHD-SVX01A-EN New manual describes installation, operation, and maintenance of RTHD units. (May 2003)

## Unit Identification - Nameplates

When the unit arrives, compare all nameplate data with ordering, submittal, and shipping information. A typical unit nameplate is shown in [Figure 1](#).

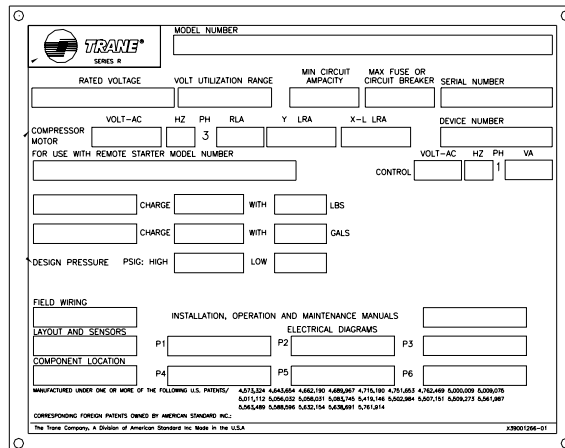

The nameplate form includes the following fields and sections:

- MODEL NUMBER**: [ ]
- RATED VOLTAGE**: [ ]
- VOLT UTILIZATION RANGE**: [ ]
- MIN CIRCUIT AMPACITY**: [ ]
- MAX FUSE OR CIRCUIT BREAKER**: [ ]
- SERIAL NUMBER**: [ ]
- COMPRESSOR MOTOR**: [ ]
- VOLT-AC**: [ ]
- HZ**: [ ]
- PH**: [ ]
- RLA**: [ ]
- Y LRA**: [ ]
- X-L LRA**: [ ]
- DEVICE NUMBER**: [ ]
- FOR USE WITH REMOTE STARTER MODEL NUMBER**: [ ]
- CONTROL**: [ ]
- VOLT-AC**: [ ]
- HZ**: [ ]
- PH**: [ ]
- VA**: [ ]
- CHARGE**: [ ] WITH [ ] LBS
- CHARGE**: [ ] WITH [ ] GALS
- DESIGN PRESSURE**: PSIG: HIGH [ ] LOW [ ]
- FIELD WIRING**: [ ]
- INSTALLATION, OPERATION AND MAINTENANCE MANUALS**: [ ]
- ELECTRICAL DIAGRAMS**: [ ]
- LAYOUT AND SENSORS**: P1 [ ] P2 [ ] P3 [ ]
- COMPONENT LOCATION**: P4 [ ] P5 [ ] P6 [ ]
- MANUFACTURED UNDER ONE OR MORE OF THE FOLLOWING U.S. PATENTS**: 4,574,524 4,644,884 4,662,190 4,699,987 4,716,190 4,751,654 4,762,489 5,000,000 5,008,076 5,017,112 5,056,032 5,096,031 5,098,140 5,419,144 5,522,364 5,527,151 5,599,273 5,641,987 5,654,480 5,696,990 5,623,104 5,630,891 5,731,814
- CORRESPONDING FOREIGN PATENTS OWNED BY AMERICAN STANDARD INC.**
- The Trane Company, A Division of American Standard Inc. Made in the U.S.A.**
- X3901226-01**

**Figure 1 Typical Unit Nameplate**

## Unit Nameplates

The RTHD "unit" nameplate is applied to the exterior surface of the starter/control panel. The "compressor" nameplate is applied to the compressor. The starter/control panel nameplate is located inside the panel.

The unit nameplate provides the following information:

- Unit model
- Unit Serial Number
- Unit device number.
  - Identifies unit electrical requirements
  - Lists correct operating charges of HFC-134a and refrigerant oil
  - Lists unit test pressures and maximum working pressures.

The starter/control panel nameplate provides the following information:

- Panel model number
- Rated load amps
- Voltage
- Electrical characteristics - starter type, wiring
- Options included.

The compressor nameplate provides the following information:



## General Information

---

- Compressor model descriptor
- Compressor serial number
- Compressor device number
- Motor serial number
- Compressor electrical characteristics
- Refrigerant.

### Unit Inspection

When the unit is delivered, verify that it is the correct unit and that it is properly equipped.

Inspect all exterior components for visible damage. Report any apparent damage or material shortage to the carrier and make a "unit damage" notation on the carrier's delivery receipt. Specify the extent and type of damage found and notify the appropriate Trane Sales Office.

Do not proceed with installation of a damaged unit without sales office approval.

### Inspection Checklist

To protect against loss due to damage incurred in transit, complete the following checklist upon receipt of the unit.

- Inspect the individual pieces of the shipment before accepting the unit. Check for obvious damage to the unit or packing material.
- Inspect the unit for concealed damage as soon as possible after delivery and before it is stored. Concealed damage must be reported within 10 days after receipt.
- If concealed damage is discovered, stop unpacking the shipment. Do not remove damaged material from the receiving location. Take photos of the damage, if possible. The owner must provide reasonable evidence that the damage did not occur after delivery.
- Notify the Trane sales representative and arrange for repair. Do not repair the unit, however, until damage is inspected by the transportation representative.

### Loose Parts Inventory

Check all items against the shipping list. Water vessel drain plugs, isolation pads, rigging and electrical diagrams, service literature and the starter/control panel wire pullbox (required on some starters) are shipped unassembled in the starter control panel.

### Unit Description

The RTHD units are single compressor, helical-rotary type, water-cooled liquid chillers designed for installation indoors. Each unit is a completely assembled, hermetic package that is factory-piped, wired, leak-tested, dehydrated, charged (optional), and tested for proper control operation before shipment.

Figure 2 and Figure 3 show a typical RTHD unit and its components. Water inlet and outlet openings are covered before shipment. The oil tank is factory charged with the proper amount of refrigeration oil. The unit can be factory charged with refrigerant.



# General Information

## Model Number Coding System

The model numbers for the unit and the compressor are composed of numbers and letters that represent features of the equipment. Shown in the three tables following are samples of typical unit, compressor, and panel model numbers, followed by the coding system for each.

Each position, or group of positions, in the model number is used to represent a feature. For example, in the first table, position 08 of the unit model number, Unit Voltage, contains the letter "F". An F in this position means that the unit voltage is 460/60/3.

## Unit Model Number

### Digit 1-4

#### Basic product line

RTHD Water-Cooled Series R

### Digit 5

#### Manufacturing Plant

U Water Chiller Business Unit,  
Pueblo CO USA  
E Epinal Business Unit, Charnes  
France  
C China Business Unit

### Digit 6 - Compressor Frame

B B compressor  
C C compressor  
D D compressor  
E E compressor

### Digit 7 - Compressor Capacity

1 Small capacity for frame  
2 Large capacity for frame  
3 For 50 hz units

### Digit 8 - Unit power supply

A 200V/60Hz/3Ph power  
C 230V/60Hz/3Ph power  
D 380V/60Hz/3Ph power  
R 380V/50Hz/3Ph power  
T 400V/50Hz/3Ph power  
U 415V/50Hz/3Ph power  
F 460V/60Hz/3Ph power  
H 575V/60Hz/3Ph power

### Digit 9 - Design Specials

X None  
C Specials denoted elsewhere  
S Specials not denoted elsewhere

### Digit 10,11 - Design sequence

\*\* First design, etc. increments when parts are affected for service purposes.

### Digit 12 - Agency listing

X No agency listing  
U C/UL listing  
3 CCC-Chinese Compulsory Code

### Digit 13 - Pressure vessel code

A ASME pressure vessel code  
L Chinese code  
S Special

### Digit 14 - Evaporator

B B evaporator  
C C evaporator  
D D evaporator  
E E evaporator  
F F evaporator  
G G evaporator

### Digit 15 - Evaporator Capacity

1 Tube count #1  
2 Tube count #2  
3 Tube count #3  
4 Tube count #4  
5 Tube count #5  
6 Tube count #6

### Digit 16 - Evap Tube type

A Enhanced Fin Copper

### Digit 17 - Evaporator passes

2 2 Pass evaporator  
3 3 Pass evaporator  
4 4 Pass evaporator

### Digit 18

#### Evaporator water connection

L Left hand evaporator connection  
R Right hand evaporator connection

### Digit 19

#### Evaporator connection type

A Standard grooved pipe  
S Special

### Digit 20

#### Evaporator water side pressure

L 150 PSI / 10.5 Bar evaporator water pressure  
H 300 PSI / 21 Bar evaporator water pressure

### Digit 21 - Condenser

B B Frame  
D D Frame  
E E Frame  
F F Frame  
G G Frame

### Digit 22 - Condenser Capacity

1 Tube count #1  
2 Tube count #2  
3 Tube count #3  
4 Tube count #4  
5 Tube count #5

### Digit 23 -Condenser tube type

A Enhanced fin - copper  
B Smooth bore - copper  
C Smooth bore - 90/10 Cu/Ni

### Digit 24 - Condenser passes

2 2 Pass

### Digit 25 -Condenser water connection

L Left hand condenser connection  
R Right hand condenser connection

### Digit 26 -Condenser connection type

A Standard grooved pipe  
C Marine  
S Special

### Digit 27

#### Condenser water side pressure

L 150 PSI / 10.5 Bar condenser water pressure  
H 300 PSI / 21 Bar condenser water pressure

### Digit 28

#### Condenser Leaving Water Temp

A Standard (<45 deg C)

### Digit 29 - Refrigerant specialties

X No refrigerant isolation valves  
V Refrigerant isolation valves

### Digit 30 - Oil Cooler

X without oil cooler  
C with oil cooler



# General Information

## Digit 31 -Thermal Insulation

- X No insulation
- Q Factory insulation cold parts

## Digit 32 -Sound Attenuator

- X No insulation
- A Standard attenuator

## Digit 33 -Control, Label, and Literature

- C Spanish
- E English
- F French

## Digit 34 -Safety Devices

- X Standard

## Digit 35 -Shipping Charge

- A Full Factory Charge (R134a)
- B Nitrogen

## Digit 36 -Shipping Package

- A No skid (standard)
- B Shrink Wrap
- C Skid
- D Skid + Shrink Wrap
- J Special

## Digit 37 -Flow Switch

- X Without
- A Evap (NEMA-1)
- B Evap & Cond (NEMA-1)
- C Evap (Vapor/NEMA -4)
- D Evap & Cond (Vapor/NEMA -4)

## Digit 38 -Factory Performance Test

- X Without
- C Witness test
- D Performance test w/report
- S Special

## Digit 39 -Starter type

- Y Wye-delta closed transition starter
- A Solid State starter

## Digit 40, 41, 42

### Design RLA (for starter)

- \*\*\* Selection RLA

## Digit 43

### Power line connection type

- A Terminal block connection for incoming line(s)
- B Mechanical disconnect switch
- D Circuit breaker
- F High interrupt circuit breaker
- H Ground fault circuit breaker
- J Ground fault high interrupt circuit breaker

## Digit 44 -Enclosure type

- F NEMA 1 - MRLA207
- G NEMA 1 - MRLA277
- H NEMA 1 - MRLA300
- J NEMA 1 - MRLA364
- K NEMA 1 - MRLA397
- L NEMA 1 - MRLA476
- M NEMA 1 - MRLA500
- N NEMA 1 - MRLA598
- P NEMA 1 - MRLA779

## Digit 45 -Under/over voltage protection

- X No under/over voltage protection
- U Under/over voltage protection

## Digit 46 -Unit operator interface

- A Dyna-View/English
- B Dyna-View/French
- C Dyna-View/Italian
- D Dyna-View/Spanish
- E Dyna-View/German
- F Dyna-View/Dutch
- G Dyna-View/Trad.Chinese
- H Dyna-View/Simp.Chinese
- J Dyna-View/Japanese
- K Dyna-View/Portugese(Brazil)
- L Dyna-View/Korean
- M Dyna-View/Thai

## Digit 47

### Remote Interfaces (digital comm)

- X No remote digital comm
- 4 Tracer Comm 4 Interface
- 5 Tracer Comm 5 LCI-C (LonTalk )

## Digit 48

### External Chilled Water & Current Limit Setpoint

- X None
- 4 4-20 mA input
- 2 2-10 Vdc input

## Digit 49

### External Base Loading

- X None
- 4 4-20 mA input
- 2 2-10 Vdc input

## Digit 50 -Icemaking

- X None
- A Icemaking with relay
- B Icemaking without relay

## Digit 51 -Programmable Relays

- X None
- R Programmable Relay

## Digit 52

### Chilled water reset

- X No Sensor (return water CHW reset standard)
- T Chilled water reset - outdoor air temp

## Digit 53 - Control Outputs

- X None
- V Condenser reg. Valve out & % RLA out
- P Condenser Pressure (%HPC) & % RLA out
- D Chiller Delta P & %RLA out

## Digit 54 -Refrigerant Monitor Input

- X None
- A 100 ppm / 4-20 mA
- B 1000 ppm / 4-20 mA
- C 100 ppm / 2-10 Vdc
- D 1000 ppm / 2-10 Vdc





# General Information

**Compressor Model Number (located on compressor nameplate):**

**Table 1 Compressor Model Number**

<b>Selection Category</b>	<b>M/N Digit</b>	<b>M/N Code</b>	<b>Description of Selection</b>
Compressor Series	1-4	CHHC	Semi-Hermetic Heli-Rotor Compressor
Design Control	5	1	Pueblo
Compressor Frame	6	B	B Frame
		C	C Frame
		D	D Frame
		E	E Frame
Compressor Capacity	7	1	Smaller capacity (minor)
		2	Larger capacity (major)
		3	Special 50 Hz capacity
Motor	8	A	200V/60Hz/3
		C	230V/60Hz/3
		D	380V/60Hz/3
		F	460V/60Hz/3 or 400V/50Hz/3
		H	575V/60Hz/3
Specials	9	O	No Specials
		C	Specials Denoted Elsewhere
		S	Uncategorized Special not denoted elsewhere
Design Sequence	10-11	AO	1st Design (Factory Input)

## General Information

---

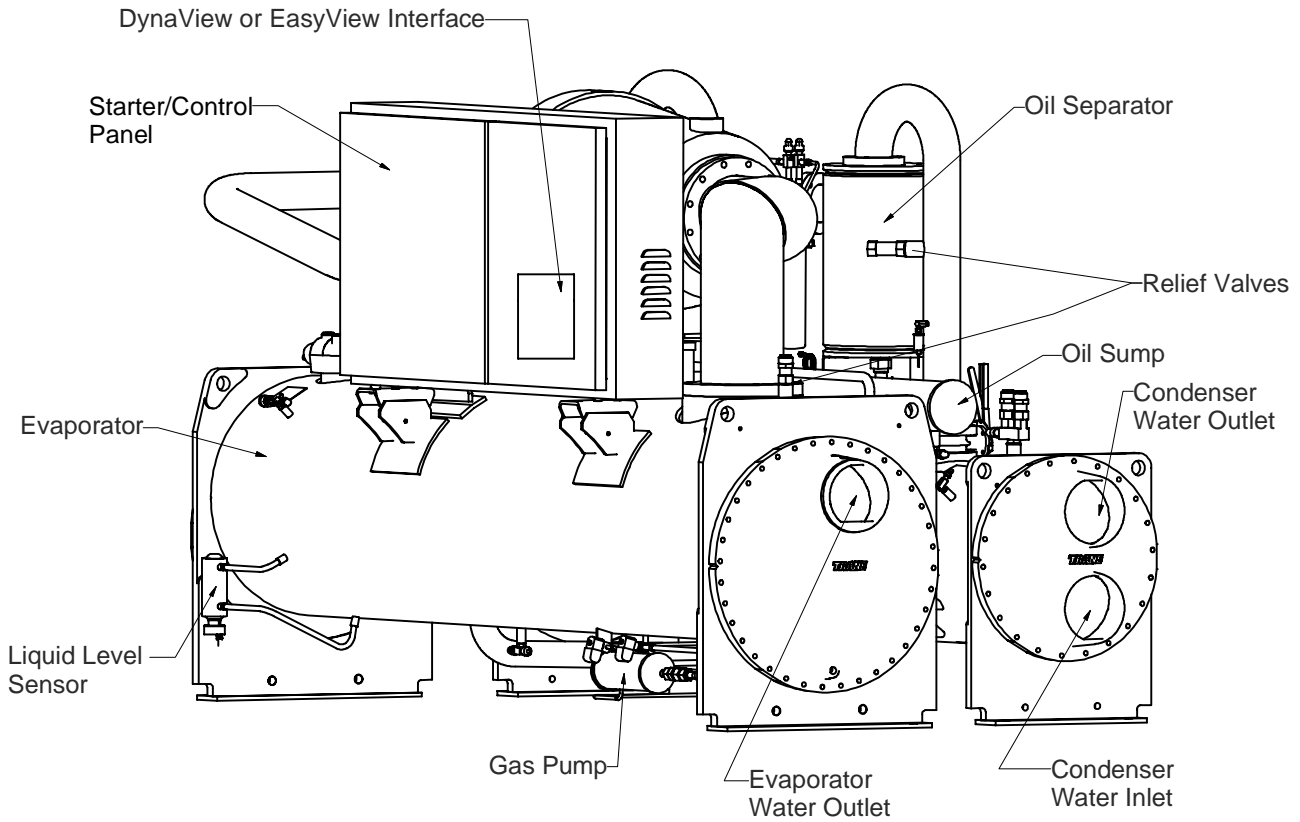

**Figure 2** Component Location for Typical RTHD Unit

## General Information

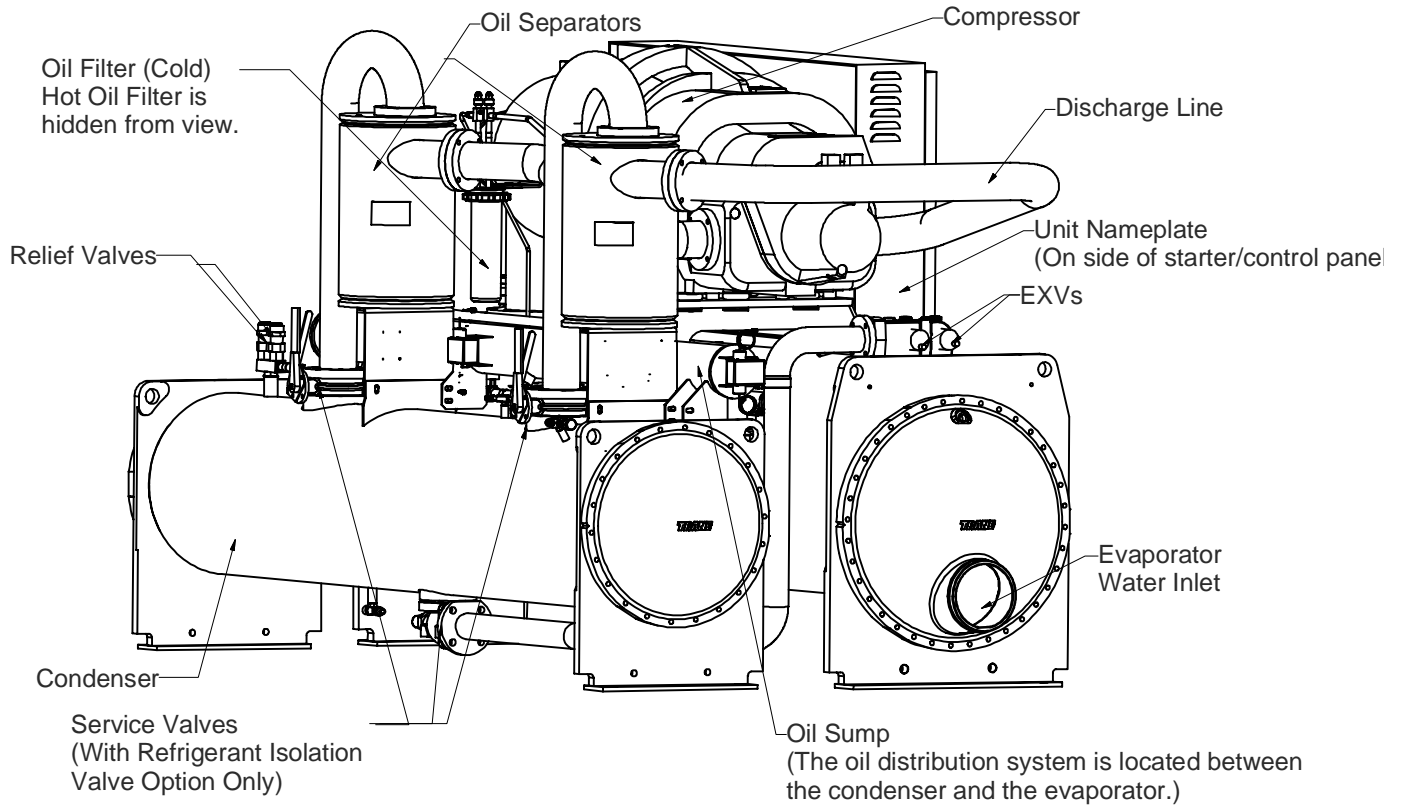

**Figure 3** Component Location for Typical RTHD Unit (Back View)



# General Information

## Installation Overview

For convenience, [Table 2](#) summarizes responsibilities that are typically associated with the RTHD chiller installation process.

**Table 2** Installation Responsibility Chart for RTHD Units

Requirement	Trane-supplied, Trane-installed	Trane-supplied, Field-installed	Field-supplied, Field-installed
Rigging			Safety chains Clevis connectors - Lifting beam
Isolation		Isolation pads	Isolation pads
Electrical	Circuit breakers or non-fused disconnects (optional) Unit-mounted starter	Circuit breaker or non-fused disconnect handle Temperature sensor (optional outdoor air) Flow switches (may be field-supplied) Condenser water regulating valve controller (optional: may be field-supplied)	Circuit breakers or fusible disconnects (optional) Terminal lugs Ground connection(s) Jumper bars BAS wiring (optional) IPC wiring Control voltage wiring High condenser pressure interlock wiring Chilled water pump contactor and wiring Condenser water pump contactor and wiring Optional relays and wiring
Water piping		Flow switches (may be field-supplied) Condenser water regulating valve controller (optional: may be field-supplied)	Thermometers Water flow pressure gauges Isolation and balancing valves water piping Vents and drain valves Pressure relief valves (for water boxes as required)
Pressure Relief	Relief valves		Vent line and flexible connector
Insulation	Insulation (optional)		Insulation

*Refer to the Installation Mechanical and Installation Electrical sections of this manual for detailed installation instructions.*

- Locate and maintain the loose parts, e.g. isolators, temperature sensors, flow sensors or other factory-ordered, field-installed options, for installation, as required. Loose parts are located in the starter/control panel.
- Install the unit on a foundation with flat support surfaces, level within 1/4" (6.35 mm) and of sufficient strength to support concentrated loading. Place the manufacturer-supplied isolation pad assemblies under the unit.
- Install the unit per the instructions outlined in the Mechanical Installation



## General Information

---

section.

- Complete all water piping and electrical connections.

*NOTE: Field piping must be arranged and supported to avoid stress on the equipment. It is strongly recommended that the piping contractor provide at least 3 feet (914 mm) of clearance between the pre-installation piping and the planned location of the unit. This will allow for proper fit-up upon arrival of the unit at the installation site. All necessary piping adjustments can be made at that time. Refer to the current engineering bulletin for further details on installation.*

- Where specified, supply and install valves in the water piping upstream and downstream of the evaporator and condenser water boxes, to isolate the shells for maintenance and to balance/trim the system.
- Supply and install condenser water control valve(s) per *Trane Engineering Bulletin -Water Cooled Series R<sup>®</sup> Condenser Water Control*.
- Supply and install flow switches or equivalent devices in both the chilled water and condenser water piping. Interlock each switch with the proper pump starter and CH530, to ensure that the unit can only operate when water flow is established.
- Supply and install taps for thermometers and pressure gauges in the water piping, adjacent to the inlet and outlet connections of both the evaporator and the condenser.
- Supply and install drain valves on each water box.
- Supply and install vent cocks on each water box.
- Where specified, supply and install strainers ahead of all pumps and automatic modulating valves.
- Supply and install refrigerant pressure relief piping from the pressure relief to the atmosphere.
- If necessary, supply enough HCFC-134 refrigerant and dry nitrogen (75 psig) for pressure testing.
- Start the unit under supervision of a qualified service technician.
- Where specified, supply and insulate the evaporator and any other portion of the unit, as required, to prevent sweating under normal operating conditions.
- For unit-mounted starters, cutouts are provided at the top of the panel for line-side wiring.
- Supply and install the wire terminal lugs to the starter.
- Supply and install field wiring to the line-side lugs of the starter.



# General Information

**Table 3 General Data**

	<b>Unit Designator (corresponds to digits 6, 7, 14, 15, 21, 22 of unit model number)</b>						
	<b>D1D1E1</b>	<b>D1F1F2</b>	<b>D1G1G1</b>	<b>D1G2G2</b>	<b>D2D2E2</b>	<b>D2F2F3</b>	<b>D2G3G3</b>
<b>General</b>							
Refrigerant Type	HFC-134a	HFC-134a	HFC-134a	HFC-134a	HFC-134a	HFC-134a	HFC-134a
Refrigerant Charge (lb (kg))	475 (216)	625 (284)	700 (318)	700 (318)	475 (216)	625 (284)	700 (318)
Oil Charge (gal (l))	6 (23)	10 (38)	11 (42)	11 (42)	6 (23)	10 (38)	11 (42)
Operating Weight (lb (kg))	15385 (6978)	17537 (7955)	20500 (9299)	21065 (9555)	15570 (7063)	18220 (8265)	21641 (9816)
Shipping Weight (lb (kg))	14443 (6551)	16187 (7342)	18600 (8437)	19107 (8667)	14562 (6605)	16820 (7630)	19508 (8849)
<b>Overall Dimensions</b>							
<b>Length (in (mm))*</b>	126 (3189)	144 (3669)	146 (3712)	146 (3712)	126 (3189)	144 (3669)	146 (3712)
<b>Width (in (mm))*</b>	68 (1717)	68 (1716)	70 (1771)	70 (1771)	68(1717)	68 (1716)	70 (1771)
<b>Height (in (mm))*</b>	76 (1717)	76 (1716)	80 (2033)	80 (2033)	76 (1937)	76 (1936)	80 (2033)
<b>Evaporator</b>							
Water Storage (gal (l))	69 (261)	102 (386)	136 (515)	144 (545)	74 (280)	107 (405)	159 (602)
Minimum Flow (gpm (l/s))	415 (26) for 2-pass	563 (36) 2-pass	505 (35) 3 pass	550 (35) for 3-pass	450 (28) for 2-pass	604 (38) for 2-pass	622 (39) for 3-pass
Water	275 (17) for 3-pass	376 (24) 3-pass	379 (24) 4 pass	411 (26) for 4-pass	300 (20) for 3-pass	404 (25) for 3-pass	466 (29) for 4-pass
Minimum Flow (gpm (l/s))Brine	498 (31) for 2-pass	676 (43) 2-pass	606 (38) 3 pass	660 (42) for 3-pass	541 (34) for 2-pass	725 (46) for 2-pass	747 (47) for 3-pass
	330 (21) for 3-pass	454 (29) 3-pass	454 (29) 4 pass	492 (31) for 4-pass	357 (23) for 3-pass	487 (31) for 3-pass	557 (35) for 4-pass
Maximum Flow (gpm (l/s))	1812 (114) for 2-pass	2478 (156) for 2-pass	2218 3 pass	2413 (152) for 3-pass	1980 (125) for 2-pass	2667 (168) for 2-pass	2732 (172) for 3-pass
	1206 (76) for 3-pass	1655 (104) for 3-pass	1666 4 pass	1807 (114) for 4-pass	1320 (83) for 3-pass	1780 (112) for 3-pass	2050 (129) for 4-pass
<b>Condenser (all are 2-pass)</b>							
<b>Water Storage (gal (l))</b>	44 (166)	57 (216)	79 (299)	91 (344)	47 (178)	61 (231)	97 (367)
<b>Minimum Flow (gpm (l/s))Water</b>	291 (18)	355 (22)	444 (28)	535 (34)	316 (20)	385 (24)	589 (37)
<b>Minimum Flow (gpm (l/s))Brine</b>	350 (22)	430 (27)	530 (33)	650 (41)	380 (24)	460 (29)	710 (45)
<b>Max Flow (gpm (l/s))</b>	1280 (81)	1560 (98)	1960 (124)	2360 (149)	1390 (88)	1700 (107)	2600 (164)

All weights ±3%, include standard 150 psig water boxes.

Operating weights include refrigerant, oil, and water charges.

If oil cooler is installed, add 1/4 gal (1 liter) to the oil charge value given for **B family** units; add 1.0 gal (4 liters) for all other units.

Overall dimensions are based on 3-pass evap/2 pass cond and LH/RH water connections. Refer to submittals for exact job conf.



# General Information

**Table 4 General Data**

	Unit Designator (corresponds to digits 6, 7, 14, 15, 21, 22 of unit model number)								
	D2G2G1	D3D2E2	D3F2F3	D3G2G1	D3G3G3	E3D2E2	E3F2F3	E3G2G1	E3G3G3
<b>General</b>									
<i>Refrigerant Type</i>	HFC-134a	HFC-134a	HFC-134a	HFC-134a	HFC-134a	HFC-134a	HFC-134a	HFC-134a	HFC-134a
<i>Rfgt Chg (lb (kg))</i>	700 (318)	475 (216)	625 (284)	700 (318)	700 (318)	475 (216)	625 (284)	700 (318)	700 (318)
<i>Oil Charge (gal (l))</i>	11 (42)	6 (23)	10 (38)	11 (42)	11 (42)	6 (23)	10 (38)	11 (42)	11 (42)
<i>Operating Weight (lb (kg))</i>	20700 (9389)	15570 (7063)	18220 (8265)	20700 (9389)	21641 (9816)	15728 (7134)	18356 (8326)	20800 (9435)	21786 (9882)
<i>Shipping Weight (lb (kg))</i>	18700 (8482)	14562 (6605)	16820 (7630)	18700 (8482)	19508 (8849)	14720 (6677)	16956 (7695)	18800 (85528)	19653 (8915)
<b>Overall Dimensions</b>									
<i>Length (in (mm))</i>	146 (3712)	126 (3189)	144 (3669)	146 (3712)	146 (3712)	126 (3189)	144 (3669)	146 (3712)	146 (3712)
<i>Width (in (mm))</i>	70 (1771)	68 (1717)	68 (1716)	70 (1771)	70 (1771)	68 (1717)	67 (7716)	70 (1771)	70 (1771)
<i>Height (in (mm))</i>	80 (2033)	76 (1937)	76 (1936)	80 (2033)	80 (2033)	76 (1937)	76 (1936)	80 (2033)	80 (2033)
<b>Evaporator</b>									
<i>Water Storage (gal (l))</i>	144 (545)	74 (280)	107 (405)	144 (545)	159 (602)	74 (280)	107 (405)	144 (545)	159 (602)
<i>Minimum Flow (gpm (l/s))Water</i>	550 (35) 3-pass	405 (28) for 2-pass	604 (38) 2-pass	550 (35) 3-pass	622 (39) 3-pass	405 (28) 2-pass	604 (38) 2-pass	550 (35) 3-pass	622 (39) 3-pass
	411 (26) 4-pass	300 (19) for 3-pass	404 (25) 3-pass	411 (26) 4-pass	466 (29) 4-pass	300 (19) 3-pass	404 (25) 3-pass	411 (26) 4-pass	466 (29) 4-pass
<i>Minimum Flow (gpm (l/s))Brine</i>	660 (42) 3-pass	541 (34) for 2-pass	725 (46) 2-pass	660 (42) 3-pass	747 (47) 3-pass	541 (34) 2-pass	725 (46) 2-pass	660 (42) 3-pass	747 (47) 3-pass
	492 (31) 4-pass	357 (23) for 3-pass	487 (31) 3-pass	492 (31) 4-pass	557 (35) 4-pass	357 (23) 3-pass	487 (31) 3-pass	492 (31) 4-pass	557 (35) 4-pass
<i>Max Flow (gpm (l/s))</i>	2413 (152) for 3-pass	1980 (125) for 2-pass	2667 (168) for 2-pass	2413 (152) for 3-pass	2732 (172) for 3-pass	1980 (125) 2-pass	2667 (168) for 2-pass	2413 (152) for 3-pass	2732 (172) for 3-pass
	1807 (114) for 4-pass	1320 (83) for 3-pass	1780 (112) for 3-pass	1807 (114) for 4-pass	2050 (129) for 4-pass	1320 (83) for 3-pass	1780 (112) for 3-pass	1807 (114) for 4-pass	2050 (129) for 4-pass
<b>Condenser (all are 2-pass)</b>									
<i>Water Storage (gal (l))</i>	79 (299)	47 (178)	61 (231)	79 (299)	97 (367)	47 (178)	61 (231)	79 (299)	97 (367)
<i>Minimum Flow (gpm (l/s))Water</i>	444 (28)	316 (20)	355 (22)	444 (28)	589 (37)	316 (20)	355 (22)	444 (28)	589 (37)
<i>Min Flow (gpm (l/s))Brine</i>	530 (33)	380 (24)	460 (29)	530 (33)	710 (45)	380 (24)	460 (29)	530 (33)	710 (45)
<i>Max Flow (gpm (l/s))</i>	1960 (124)	1390 (88)	1700 (107)	1960 (124)	2600 (164)	1390 (88)	1700 (107)	1960 (124)	2600 (164)

All weights ±3%, include standard 150 psig water boxes.

Operating weights include refrigerant, oil, and water charges.

If oil cooler is installed, add 1/4 gal (1 liter) to the oil charge value given for **B family** units; add 1.0 gal (4 liters) for all other units.

Overall dimensions are based on 3-pass evap/2 pass cond and LH/RH water connections. Refer to submittals for exact job configurations



# General Information

Table 5 General Data

	Unit Designator (corresponds to digits 6, 7, 14, 15, 21, 22 of unit model number)				
	C1D6E5	C1D5E4	C1E1F1	C2D4E4	C2D3E3
<b>General</b>					
Refrigerant Type	HFC-134a	HFC-134a	HFC-134a	HFC-134a	HFC-134a
Refrigerant Charge (lb (kg))	490 (222)	490 (222)	525 (238)	490 (222)	490 (222)
Oil Charge (gal (l))	6 (23)	6 (23)	10 (38)	6 (23)	6 (23)
Operating Weight (lb (kg))	13397 (6077)	13673 (6202)	15818 (7175)	13672 (6202)	15044 (6824)
Shipping Weight (lb (kg))	12780 (5797)	12973 (5885)	14718 (6675)	12972 (5884)	14002 (6351)
<b>Overall Dimensions</b>					
Length (in (mm))*	126 (3194)	126 (3194)	144 (3650)	126 (3194)	126 (3194)
Width (in (mm))*	68 (1717)	68 (1717)	68 (1715)	68 (1717)	68 (1717)
Height (in (mm))*	76 (1937)	76 (1937)	76 (1937)	76 (1937)	76 (1937)
<b>Evaporator</b>					
Water Storage (gal (l))	45 (170)	52 (197)	82 (311)	52 (197)	78 (295)
Minimum Flow (gpm (l/s)) Water	293 (18) for 2-pass	351 (21) for 2-pass	450 (28) for 2-pass	351 (21) for 2-pass	465 (31) for 2-pass
	196 (12) for 3-pass	234 (15) or 3-pass	300 (19) for 3-pass	234 (15) or 3-pass	324 (20) for 3-pass
Minimum Flow (gpm (l/s)) Brine	352 (22) for 2-pass	422 (27) for 2-pass	487 (31) for 2-pass	422 (27) for 2-pass	584 (37) for 2-pass
	233 (15) for 3-pass	281 (18) or 3-pass	357 (23) for 3-pass	281 (18) or 3-pass	389 (25) for 3-pass
Maximum Flow (gpm (l/s))	1287 (81) for 2-pass	1542 (97) or 2-pass	1980 (125) for 2-pass	1542 (97) or 2-pass	2131 (134) for 2-pass
	860 (54) for 3-pass	1028 (65) or 3-pass	1320 (83) for 3-pass	1028 (65) or 3-pass	1417 (89) for 3-pass
<b>Condenser</b>					
<b>(all are 2-pass)</b>					
Water Storage (gal (l))	29 (110)	32 (121)	60 (226)	32 (121)	47 (178)
Minimum Flow (gpm (l/s)) Water	206 (13)	245 (15)	375 (24)	245 (15)	325 (21)
Minimum Flow (gpm (l/s)) Brine	250 (16)	295 (19)	450 (28)	295 (19)	390 (25)
Maximum Flow (gpm (l/s))	910 (57)	1080 (68)	1650 (104)	1080 (68)	1420 (90)

All weights  $\pm 3\%$ , include standard 150 psig water boxes.

Operating weights include refrigerant, oil, and water charges.

If oil cooler is installed, add 1/4 gal (1 liter) to the oil charge value given for **B family** units; add 1.0 gal (4 liters) for all other units.

Overall dimensions are based on 3-pass evap/2 pass cond and LH/RH water connections. Refer to submittals for exact job configurations





# General Information

**Table 6 General Data**

	<b>Unit Designator (corresponds to digits 6, 7, 14, 15, 21, 22 of unit model number)</b>				
	<b>C2F2F3</b>	<b>B1B1B1</b>	<b>B1C1D1</b>	<b>B2B2B2</b>	<b>B2C2D2</b>
<b>General</b>					
<i>Refrigerant Type</i>	HFC-134a	HFC-134a	HFC-134a	HFC-134a	HFC-134a
<i>Refrigerant Charge (lb (kg))</i>	700 (318)	410 (186)	490 ((222)	410 (186)	490 ((222)
<i>Oil Charge (gal (l))</i>	11 (42)	4.5 (17.0)	4.5 (17.0)	4.5 (17.0)	4.5 (17.0)
<i>Operating Weight (lb (kg))</i>	17560 (7965)	9867 (4476)	10554 (4787)	10019 (4544)	10653 (4832)
<i>Shipping Weight (lb (kg))</i>	16168 (7334)	9292 (4215)	9837 (4462)	9402 (4265)	9953 (4515)
<b>Overall Dimensions</b>					
<i>Length (in (mm))*</i>	144 (3658)	124 (3160)	143 (3624)	124 (3160)	143 (3624)
<i>Width (in (mm))*</i>	68 (1727)	64 (1634)	64 (1634)	64 (1634)	64 (1634)
<i>Height (in (mm))*</i>	76 (1930)	73 (1849)	73 (1849)	73 (1849)	72 (1849)
<b>Evaporator</b>					
<i>Water Storage (gal (l))</i>	107 (405)	41 (155)	55 (208)	45 (170)	58 (220)
<i>Minimum Flow (gpm (l/s)) Water</i>	604 (38) for 2-pass	253 (16) for 2-pass	320 (18) for 2-pass	288 (22) for 2-pass	347 (22) for 2-pass
	404 (25) for 3-pass	168 (11) for 3-pass	213 (12) for 3-pass	192 (15) for 3-pass	232 (15) for 3-pass
<i>Minimum Flow (gpm (l/s)) Brine</i>	725 (46) for 2-pass	303 (19) for 2-pass	346 (22) for 2-pass	346 (22) for 2-pass	375 (24) for 2-pass
	487 (31) for 3-pass	200 (13) for 3-pass	254 (16) for 3-pass	233 (15) for 3-pass	276 (17) for 3-pass
<i>Maximum Flow (gpm (l/s))</i>	2667 (168) for 2-pass	1104 (70) for 2-pass	1412 (89) for 2-pass	1266 (80) for 2-pass	1531 (97) for 2-pass
	1780 (112) for 3-pass	736 (46) for 3-pass	941 (59) for 3-pass	844 (53) for 3-pass	1022 (65) for 3-pass
<b>Condenser</b>					
<b>(all are 2-pass)</b>					
<i>Water Storage (gal (l))</i>	61 (231)	28 (106)	31 (117)	29 (110)	34 (129)
<i>Minimum Flow (gpm (l/s)) Water</i>	355 (22)	193 (12)	193 (12)	212 (13)	212 (13)
<i>Minimum Flow (gpm (l/s)) Brine</i>	460 (29)	230 (15)	230 (15)	255 (16)	255 (16)
<i>Maximum Flow (gpm (l/s))</i>	1700 (107)	850 (54)	850 (54)	935 (59)	935 (59)

All weights  $\pm 3\%$ , include standard 150 psig water boxes.

Operating weights include refrigerant, oil, and water charges.

If oil cooler is installed, add 1/4 gal (1 liter) to the oil charge value given for **B family** units; add 1.0 gal (4 liters) for all other units.

Overall dimensions are based on 3-pass evap/2 pass cond and LH/RH water connections. Refer to submittals for exact job configurations



## **General Information**

---



# Installation Mechanical

---

## Storage

If the chiller is to be stored more than one month prior to installation, observe the following precautions:

- Do not remove the protective coverings from the electrical panel.
- Store the chiller in a dry, vibration-free, secure area.
- At least every three months, attach a gauge and manually check the pressure in the refrigerant circuit. If the refrigerant pressure is below 71 psig at 70°F (or 46 psig at 50°F), call a qualified service organization and the appropriate Trane sales office.

*NOTE: Pressure will be approximately 20 psig if shipped with the optional nitrogen charge.*

## Location Requirements

### Noise Considerations

- Refer to *Trane Engineering Bulletin -Series R<sup>®</sup> Chiller Sound Ratings and Installation Guide*.

for sound consideration applications.

- Locate the unit away from sound-sensitive areas.
- Install the isolation pads under the unit. Refer to "Unit Isolation."
- Install rubber vibration isolators in all water piping.
- Use flexible electrical conduit for final connection to the CH530.
- Seal all wall penetrations.

*NOTE: Consult an acoustical engineer for critical applications.*

### Foundation

Provide rigid, non-warping mounting pads or a concrete foundation of sufficient strength and mass to support the chiller operating weight (including completed piping and full operating charges of refrigerant, oil and water). Refer to [Table 7](#) for unit operating weights.

Once in place, level the chiller within 1/4" (6.35 mm) over its length and width.

The Trane Company is not responsible for equipment problems resulting from an improperly designed or constructed foundation.

### Vibration Eliminators

- Provide rubber boot type isolators for all water piping at the unit.
- Provide flexible conduit for electrical connections to the unit.
- Isolate all pipe hangers and be sure they are not supported by main structure beams that could introduce vibration into occupied spaces.
- Make sure that the piping does not put additional stress on the unit.

*NOTE: Do not use metal braided type eliminators on the water piping. Metal braided eliminators are not effective at the frequencies at which the unit will operate.*

# Installation Mechanical

## Clearances

Provide enough space around the unit to allow the installation and maintenance personnel unrestricted access to all service points. Refer to submittal drawings for the unit dimensions.

Allow adequate clearance for condenser and compressor servicing. A minimum of three feet is recommended for compressor service and to provide sufficient clearance for the opening of control panel doors. Refer to [Figure 4](#) for minimum clearances required for condenser tube service. In all cases, local codes will take precedence over these recommendations.

*NOTE: Required vertical clearance above the unit is 36" (914.4 mm). There should be no piping or conduit located over the compressor motor.*

If the room configuration requires a variance to the clearance dimensions, contact your Trane sales office representative.

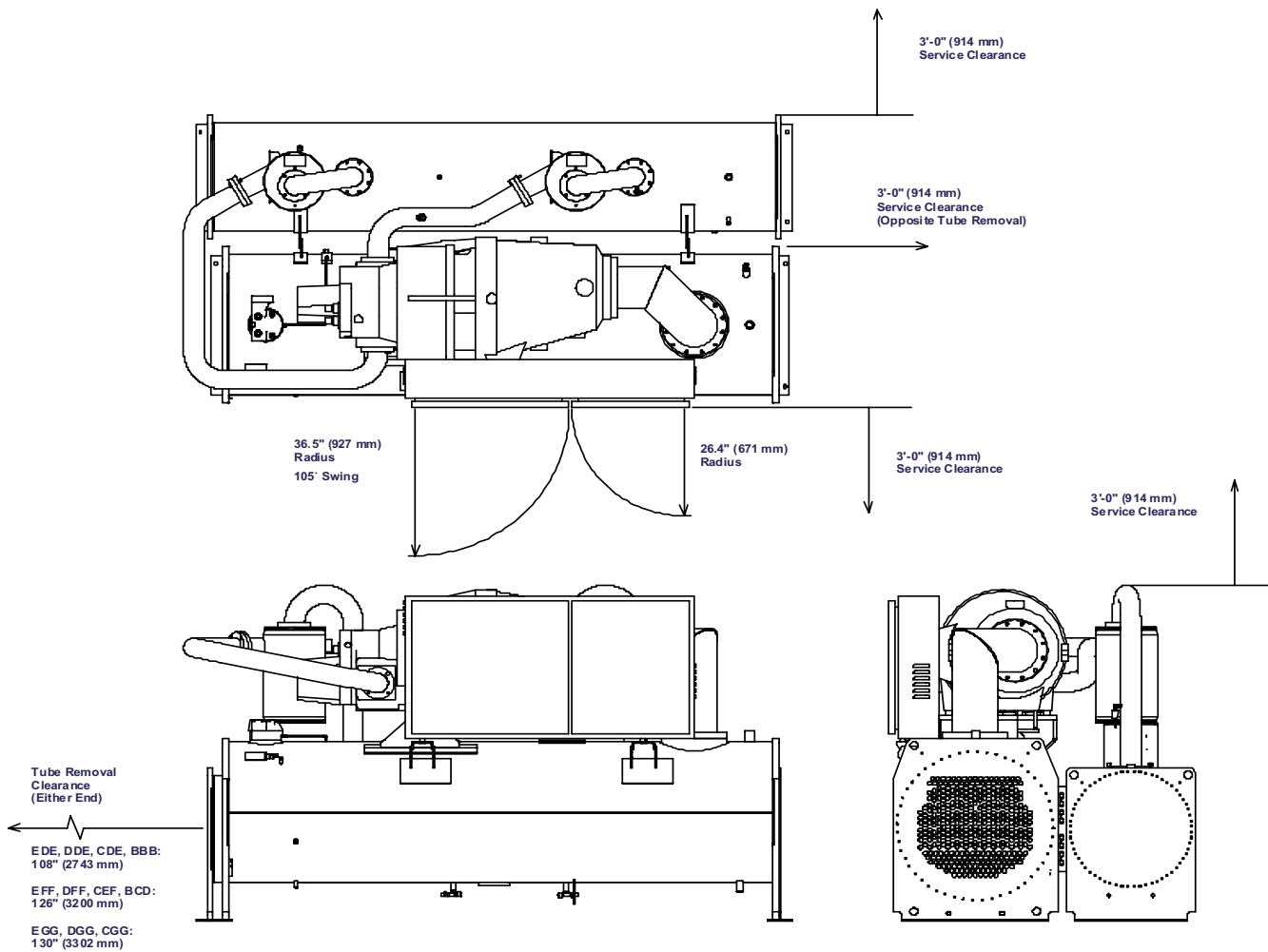

**Figure 4** Recommended Operating and Service Clearances



# Installation Mechanical

---

*NOTE: Maximum clearances are given. Depending on the unit configuration, some units may require less clearance than others in the same category.*

## **Ventilation**

The unit produces heat even though the compressor is cooled by the refrigerant. Make provisions to remove heat generated by unit operation from the equipment room. Ventilation must be adequate to maintain an ambient temperature lower than 122°F (50°C).

Vent the evaporator, condenser and compressor pressure relief valves in accordance with all local and national codes. Refer to [Table 11](#).

Make provisions in the equipment room to keep the chiller from being exposed to freezing temperatures (32°F/0°C).

## **Water Drainage**

Locate the unit near a large capacity drain for water vessel drain-down during shutdown or repair. Condensers and evaporators are provided with drain connections. Refer to "Water Piping." All local and national codes apply.

## **Access Restrictions**

Door clearances for the RTHD units are given in [Figure 5](#). Refer to the unit submittals for specific "per unit" dimensional information.

## **Moving and Rigging**

The Model RTHD chiller should be moved by lifting at designated lift points only. Refer to [Figure 6](#) and [Table 7](#) for typical unit lifting and operating weights. Refer to the rigging diagram that ships with each unit for specific "per unit" weight data.

## **⚠ WARNING**

### **Heavy Equipment!**

**Always use lifting equipment with a capacity exceeding unit lifting weight by an adequate safety factor. (+10%). Follow the procedures and diagrams in this manual and in the submittal. Failure to do so can result in death or serious injury.**

# Installation Mechanical

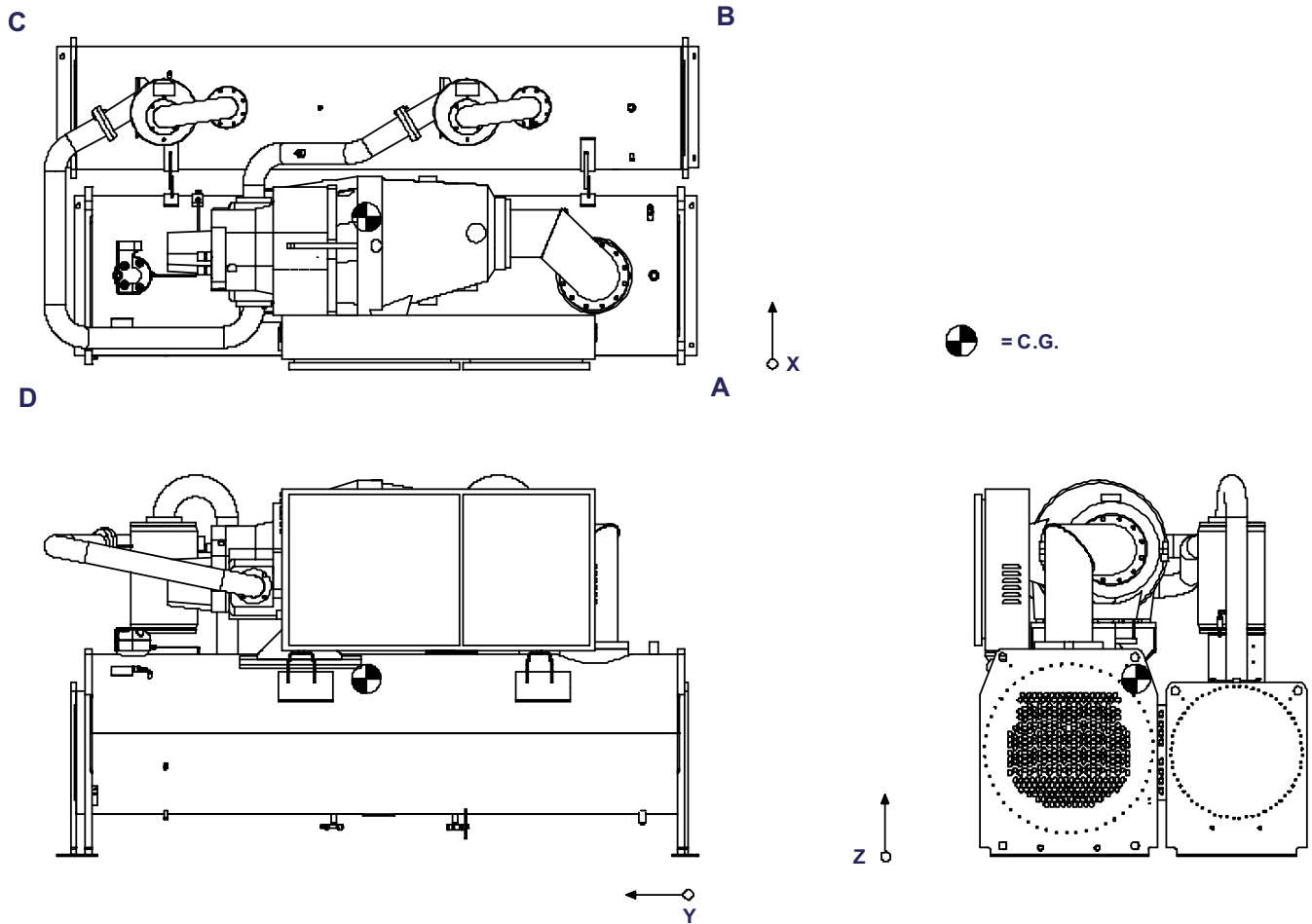

**Figure 5 Unit Weights and Dimensions for Rigging**

**Table 7 Unit Weights (lb (kg))**

Unit Designator *	Location (points)			
	A	B	C	D
E3G3G3	5339 (2422)	4455 (2021)	4374 (1984)	5486 (2488)
E3G2G1	5158 (2340)	4304 (1952)	4226 (1917)	5300 (2404)
E3F2F3	4781 (2169)	3582 (1625)	3750 (1701)	4851 (2200)
E3D2E2	3796 (1722)	2834 (1285)	3300 (1497)	4789 (2172)

\*Unit Designator (corresponds to digits 6, 7, 14, 15, 21, 22 of unit model number)



# Installation Mechanical

**Table 7 Unit Weights (lb (kg))**

Unit Designator *	Location (points)			
	A	B	C	D
D3G3G3	5320 (2413)	4451 (2019)	4327 (1963)	5140 (2331)
D3G2G1	5085 (2307)	4255 (1930)	4136 (1876)	5171 (2346)
D3F2F3	4737 (2149)	3563 (1616)	3722 (1688)	4797 (2176)
D3D2E2	3754 (1703)	2818 (1278)	3269 (1483)	4720 (2141)
D2G3G3	5320 (2413)	4451 (2019)	4327 (1963)	5140 (2331)
D2 G2G1	5085 (2307)	4255 (1930)	4136 (1876)	5171 (2346)
D2F2F3	4737 (2149)	3563 (1616)	3722 (1716)	4797 (2176)
D2D2E2	3754 (1703)	2818 (1278)	3269 (1483)	4720 (2141)
D1G1G1	4981 (2259)	4148 (1882)	4041 (1833)	5076 (2302)
D1G2G2	5216 (2366)	4344 (1970)	4231 (1919)	5316 (2411)
D1F1F2	4526 (2053)	3452 (1566)	3615 (1640)	4594 (2084)
D1D1E1	3728 (1691)	2758 (1251)	3236 (1468)	4694 (2129)
C2F2F3	4649 2109	3496 1586	4707 2135	4707 2135
C2D3E3	3612 (1638)	2738 (1242)	3148 (1428)	4503 (2043)
C2D4E4	3374 (1530)	2479 (1124)	2876 (1305)	4243 (1925)
C1E1F1	4205 (1907)	3046 (1382)	3196 (1450)	4271 (1937)
C1D5E4	3375 (1531)	2479 (1124)	2876 (1305)	4243 (1925)
C1D6E5	3330 (1510)	2430 (1102)	2825 (1281)	4195 (1903)
B2C2D2	3162 (1510)	2297 (1042)	1767 (802)	2726 (1237)
B2B2B2	2522 (1144)	1996 (905)	1926 (874)	2958 (1342)
B1C1D1	3136 (1422)	2264 (1027)	1739 (789)	2698 (1224)
B1B1B1	2495 (1132)	1969 (893)	1901 (862)	2928 (1328)

\*Unit Designator (corresponds to digits 6, 7, 14, 15, 21, 22 of unit model number)



# Installation Mechanical

**Table 8 Center of Gravity (in (mm))**

Unit Configuration*	X	Y	Z
E3G3G3	30.8 (782.32)	63.81 (1621)	37.62 (956)
E3G2G1	30.8 (782.32)	63.55 (1614)	38.70 (983)
E3F2F3	27.64 (702.056)	63.46 (1612)	38.33 (974)
E3D2E2	25.9 (658)	60.05 (1525)	40.5 (1029)
D3G3G3	30.85 (784)	63.48 (1612)	37.44 (951)
D3G2G1	30.58 (777)	68.56 (1741)	37.79 (960)
D3F2F3	27.7 (704)	63.4 (1610)	38.14 (969)
D3D2E2	25.97 (660)	59.95 (1523)	40.31 (1024)
D2G3G3	30.85 (784)	63.48 (1612)	37.44 (951)
D2G2G1	30.58 (777)	68.56 (1741)	37.79 (960)
D2F2F3	27.7 (704)	63.4 (1610)	38.14 (969)
D2D2E2	25.97 (660)	59.95 (1523)	40.31 (1024)
D1G1G1	30.58 (777)	68.56 (1741)	37.79 (960)
D1G2G2	30.77 (782)	63.55 (1614)	37.72 (958)
D1F1F2	27.92 (709)	63.47 (1612)	38.7 (9833)
D1D1E1	25.91 (658)	60 (1524)	40.47 (1028)
C2F2F3	27.92 (709)	63.47 (1612)	38.7 (9833)
C2D3E3	26.13 (664)	59.74 (1517)	40.08 (1018)
C2D4E4	26.13 (664)	59.74 (1517)	40.08 (1018)
C1E1F1	26.36 (670)	63.49 (1613)	40.95 (1040)
C1D5E4	26.13 (664)	59.74 (1517)	40.08 (1018)
C1D6E5	26.13 (664)	59.74 (1517)	40.08 (1018)
B2C2D2	22.4 (569)	58.29 (1481)	33.51 (851)
B2B2B2	22.88 (581)	58.11 (1476)	35.43 (900)
B1C1D1	22.32 (567)	58.23 (1479)	33.65 (855)
B1B1B1	22.84 (580)	58.13 (1477)	35.59 (904)

Designator corresponds to digits 6, 7, 14, 15, 21, 22 of model number



# Installation Mechanical

---

## Lifting Procedure

### **CAUTION** **Equipment Damage!**

**Never use a forklift to move the unit. The skid is not designed to support the unit at any one point and using a forklift to move the equipment may cause unit damage. Always position the lifting beam so that cables do not contact the unit. Failure to do so may result in unit damage.**

*NOTE: If absolutely necessary, the chiller can be pushed or pulled across a smooth surface if it is bolted to wood shipping mounts.*

### **⚠ WARNING** **Shipping Mounts!**

**Do not use the threaded holes in the compressor to lift or assist in lifting the unit. They are not intended for that purpose and could create a dangerous situation. Do not remove the wood mounts until the unit is in its final location. Removal of wood shipping mounts prior to unit final locating could result in death or serious injury or equipment damage.**

1. When the unit is at its final location, remove the shipping bolts that secure the unit to the wood base mounts.
2. Rig the unit properly and lift from above or jack the unit (alternate moving method). Use the points shown on the rigging diagram that ships with the unit as shown in [Figure 6](#). Remove the base mounts.
3. Install clevis connectors in lifting holes provided on the unit. Attach lifting chains or cables to clevis connectors as shown in [Figure 6](#). Each cable alone must be strong enough to lift the chiller.



# Installation Mechanical

**Table 9 Rigging**

Unit Configuration*	Dimension (mm (in))					
	A	B	C	D	E	F
E3G3G3	3658 (144.02)	3353 (132.01)	1621 (63.82)	20 (0.79)	661 (26.02)	610 (24.02)
E3G2G1	3658 (144.02)	3353 (132.01)	1621 (63.82)	20 (0.79)	661 (26.02)	610 (24.02)
E3F2F3	3658 (144.02)	3353 (132.01)	1612 (63.46)	29 (1.14)	615 (24.21)	610 (24.02)
E3D2E2	3048 (120.00)	2743 (107.99)	1525 (60.04)	116 (4.57)	612 (24.09)	610 (24.02)
D3G3G3	3658 (144.02)	3353 (132.01)	1612 (63.46)	99 (3.90)	654 (25.75)	610 (24.02)
D3G2G1	3658 (144.02)	3353 (132.01)	1612 (63.46)	99 (3.90)	654 (25.75)	610 (24.02)
D3F2F3	3658 (144.02)	3353 (132.01)	1610 (63.39)	101 (3.98)	617 (24.29)	610 (24.02)
D3D2E2	3048 (120.00)	2743 (107.99)	1523 (59.96)	188 (7.40)	614 (24.17)	610 (24.02)
D2G3G3	3658 (144.02)	3353 (132.01)	1612 (63.46)	99 (3.90)	654 (25.75)	610 (24.02)
D2G2G1	3658 (144.02)	3353 (132.01)	1612 (63.46)	99 (3.90)	654 (25.75)	610 (24.02)
D2F2F3	3658 (144.02)	3353 (132.01)	1610 (63.39)	101 (3.98)	617 (24.29)	610 (24.02)
D2D2E2	3048 (120.00)	2743 (107.99)	1523 (59.96)	188 (7.40)	614 (24.17)	610 (24.02)
D1G2G2	3658 (144.02)	3353 (132.01)	1614 (63.54)	97 (3.82)	661 (26.02)	610 (24.02)
D1G1G1	3658 (144.02)	3353 (132.01)	1612 (63.46)	99 (3.90)	654 (25.75)	610 (24.02)
D1F1F2	3658 (144.02)	3353 (132.01)	1612 (63.46)	99 (3.90)	622 (24.49)	610 (24.02)
D1D1E1	3048 (120.00)	2743 (107.99)	1524 (60.00)	187 (7.36)	612 (24.09)	610 (24.02)
C2F2F3	3658 (144.02)	3353 (132.01)	1610 (63.39)	101 (3.98)	617 (24.29)	610 (24.02)
C2D3E3	3048 (120.00)	2743 (107.99)	1517 (59.72)	225 (8.86)	618 (24.33)	610 (24.02)
C2D4E4	3048 (120.00)	2743 (107.99)	1523 (59.96)	219 (8.62)	584 (22.99)	610 (24.02)

\*Designator corresponds to digits 6, 7, 14, 15, 21, 22 of model number



# Installation Mechanical

**Table 9 Rigging**

Unit Configuration*	Dimension (mm (in))					
	A	B	C	D	E	F
C1E1F1	3658 (144.02)	3353 (132.01)	1613 (63.50)	129 (5.08)	624 (24.57)	610 (24.02)
C1D5E4	3048 (120.00)	2743 (107.99)	1523 (59.96)	219 (8.62)	584 (22.99)	610 (24.02)
C1D6E5	3048 (120.00)	2743 (107.99)	1524 (60.00)	218 (8.58)	582 (22.91)	610 (24.02)
B2C2D2	3658 (144.02)	3353 (132.01)	1481 (58.31)	93 (3.66)	523 (20.59)	610 (24.02)
B2B2B2	3048 (120.00)	2743 (107.99)	1476 (58.11)	98 (3.86)	535 (21.06)	610 (24.02)
B1C1D1	3658 (144.02)	3353 (132.01)	1479 (58.23)	95 (3.74)	521 (20.51)	610 (24.02)
B1B1B1	3048 (120.00)	2743 (107.99)	1447 (56.97)	97 (3.82)	534 (21.02)	610 (24.02)

\*Designator corresponds to digits 6, 7, 14, 15, 21, 22 of model number

# Installation Mechanical

**NOTES:**

1. LIFTING CABLES (CHAINS) WILL NOT BE THE SAME LENGTH. ADJUST TO KEEP UNIT LEVEL WHILE LIFTING.
2. ATTACH ANTI-ROLLING CABLE (CHAIN) AS SHOWN WITHOUT TENSION. NOT AS A LIFTING CABLE, BUT TO PREVENT UNIT FROM ROLLING.
3. DO NOT FORK LIFT UNIT.
4. WEIGHTS ARE TYPICAL FOR UNITS WITH R-134a CHARGE.
5. IF UNIT IS DISASSEMBLED, SEE SERVICE BULLETIN FOR LIFTING AND RIGGING OF COMPONENTS.

**WARNING:** DO NOT USE CABLES (CHAINS) OR SLINGS EXCEPT AS SHOWN. OTHER LIFTING ARRANGEMENTS MAY CAUSE EQUIPMENT DAMAGE OR SERIOUS PERSONAL INJURY.

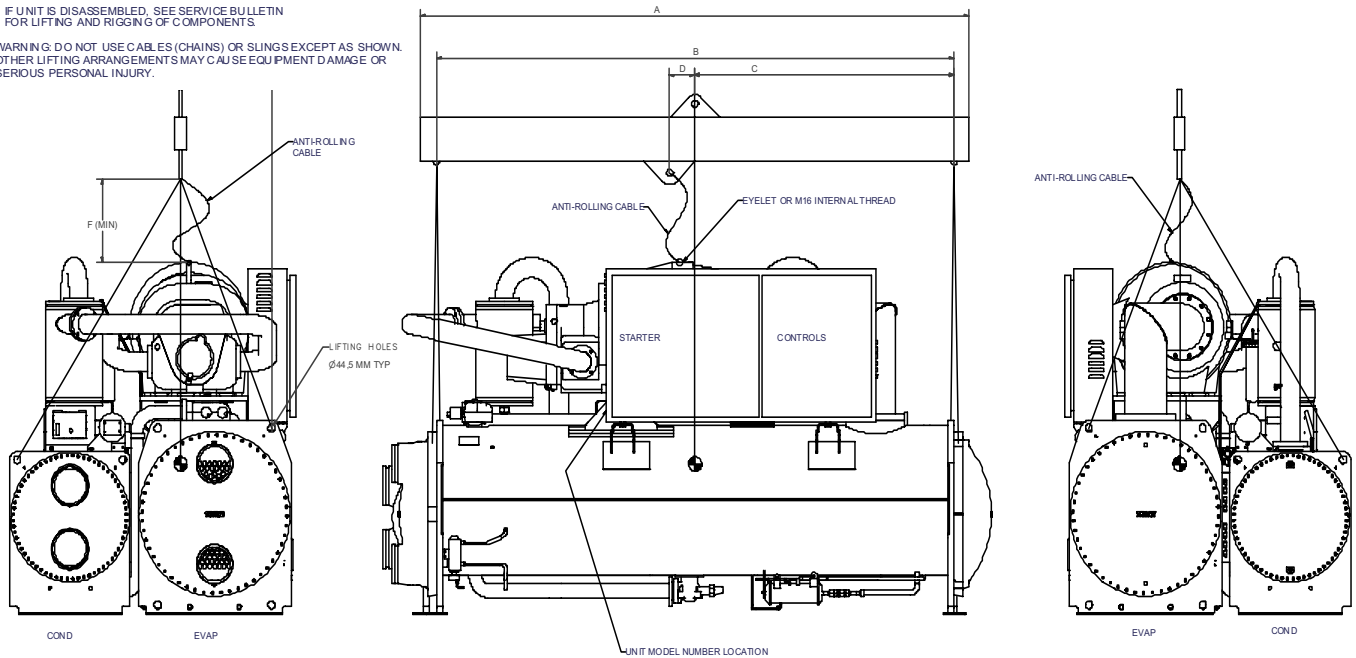

**Figure 6 Lifting the Unit**

4. Attach cables to lifting beam. Total lifting weight, lifting weight distribution and required lifting beam dimensions are shown in the rigging diagram shipped with each unit and in [Figure 6](#). The lifting beam crossbar must be positioned so the lifting cables do not contact unit piping or electrical panel enclosure.

## **⚠ WARNING** **Anti-rotation Strap!**

**Connect an anti-rotation strap between the lifting beam and compressor before lifting unit. Failure to do so may result in death or serious injury should a lifting cable fail.**

5. Connect an anti-rotation strap or cable loosely between the lifting beam and the threaded coupling or eyelet provided at the top of the compressor. Use an eyebolt or clevis to secure the strap at the coupling or eyelet.

*NOTE: The anti-rotation strap is not a lifting chain, but a safety device to ensure that the unit cannot tilt during lifting.*

# Installation Mechanical

## Alternate Moving Method

- If it is not possible to rig from above as shown in the figures, the unit may also be moved by jacking each end high enough to move an equipment dolly under each tube sheet support. Once securely mounted on the dollies, the unit may be rolled into position.

## Isolation Pads

The elastomeric pads shipped (as standard) are adequate for most installations. For additional details on isolation practices, refer to

Trane Engineering Bulletin -Series R<sup>®</sup> Chiller Sound Ratings and Installation Guide., or consult an acoustical engineer for sound-sensitive installations.

- During final positioning of the unit, place the isolation pads under the evaporator and condenser tube sheet supports as shown in Figure 7. Level the unit as described in the next main paragraph.

**NOTE:** Durometer values for isolator pads are a measure of resilience. See Figure 7.

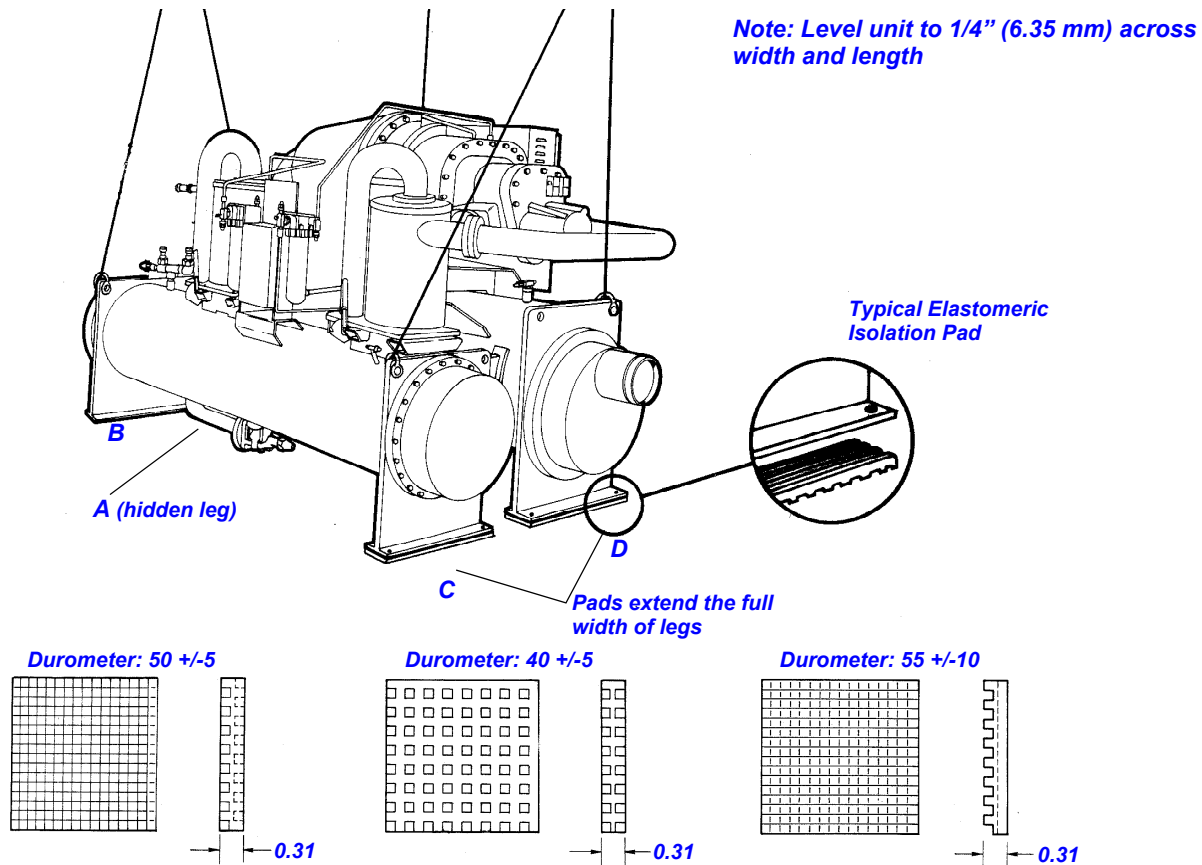
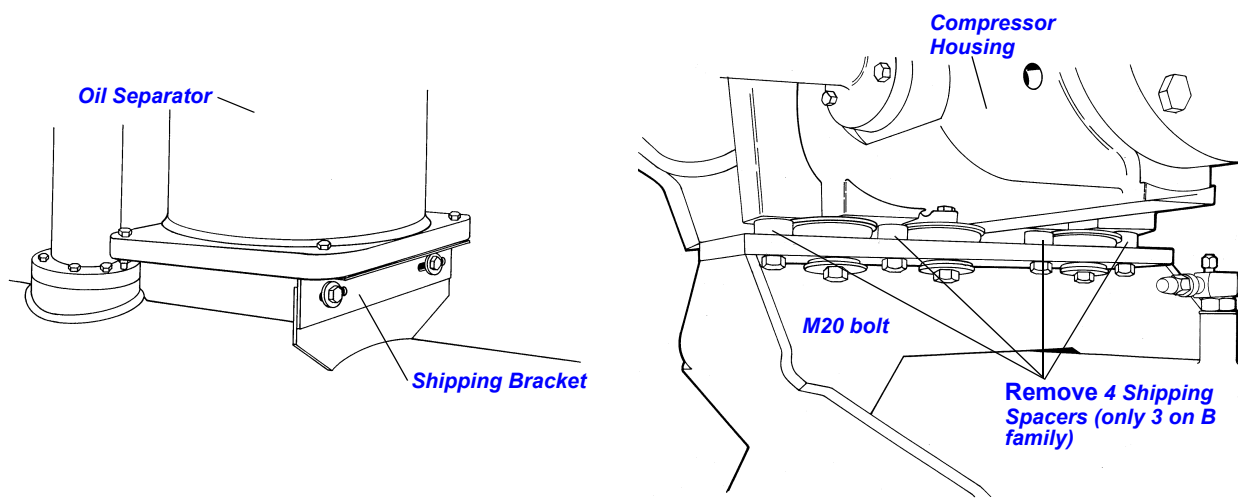

Figure 7 Isolator Pad Placement

## Installation Mechanical

8. The unit is shipped with four spacers (only three on B family) on the compressor mount that protect the compressor isolation pads during shipping and in handling. Remove these spacers (*Figure 8*) before the unit is operated.
9. Remove the shipping brackets from the bottom sides of the oil separator(s) (see *Figure 8*).

*NOTE: Once shipping bracket(s) is removed, the oil separator is only supported by the discharge line.*



**Figure 8 Oil Separator with Shipping Bracket and Compressor Shipping Spacer**

### Unit Leveling

*NOTE: The electrical panel side of the unit is designated as the "front" of the unit.*

1. Check unit level end-to-end by placing a level on the top surface of the evaporator shell.
2. If there is insufficient surface available on the top of the evaporator shell, attach a magnetic level to the bottom of the shell to level the unit. The unit should be level to within 1/4" (6.35 mm) over its length.
3. Place the level on the evaporator shell tube sheet support to check side-to-side (front-to-back) level. Adjust to within 1/4" (6.35 mm) of level front-to-back.

*NOTE: The evaporator MUST be level for optimum heat transfer and unit performance.*

4. Use full-length shims to level the unit.



# Installation Mechanical

---

## Water Piping

### Piping Connections

## CAUTION Equipment Damage!

**To prevent equipment damage, bypass the unit if using an acidic flushing agent.**

Make water piping connections to the evaporator and condenser. Isolate and support piping to prevent stress on the unit. Construct piping according to local and national codes. Insulate and flush piping before connecting to unit.

Use grooved pipe connectors for all water piping connections. Evaporator and condenser water inlet and outlet sizes and locations are shown by the unit submittals and in [Figure 9](#) through [Figure 14](#). The designation in the tables corresponds to the compressor frame code followed by the evaporator shell code followed by the condenser shell code as given in the unit model number, digits 6, 7, 14, 15, 21 and 22. [Table 10](#) gives additional water connection information.

### Reversing Water Boxes

All water boxes may be reversed end-for-end. Do not rotate water boxes. Remove the sensors from the wells before removing the water box. Complete the water box switch and replace the sensors. See [Figure 9](#) through [Figure 14](#) for correct orientation of the water inlet and outlet.

If the water boxes are reversed, be sure to properly rewire the water temperature sensors in the control panel.

*NOTE: Be certain to replace water boxes right-side-up to maintain proper baffle orientation. Use new o-rings.*

# Installation Mechanical

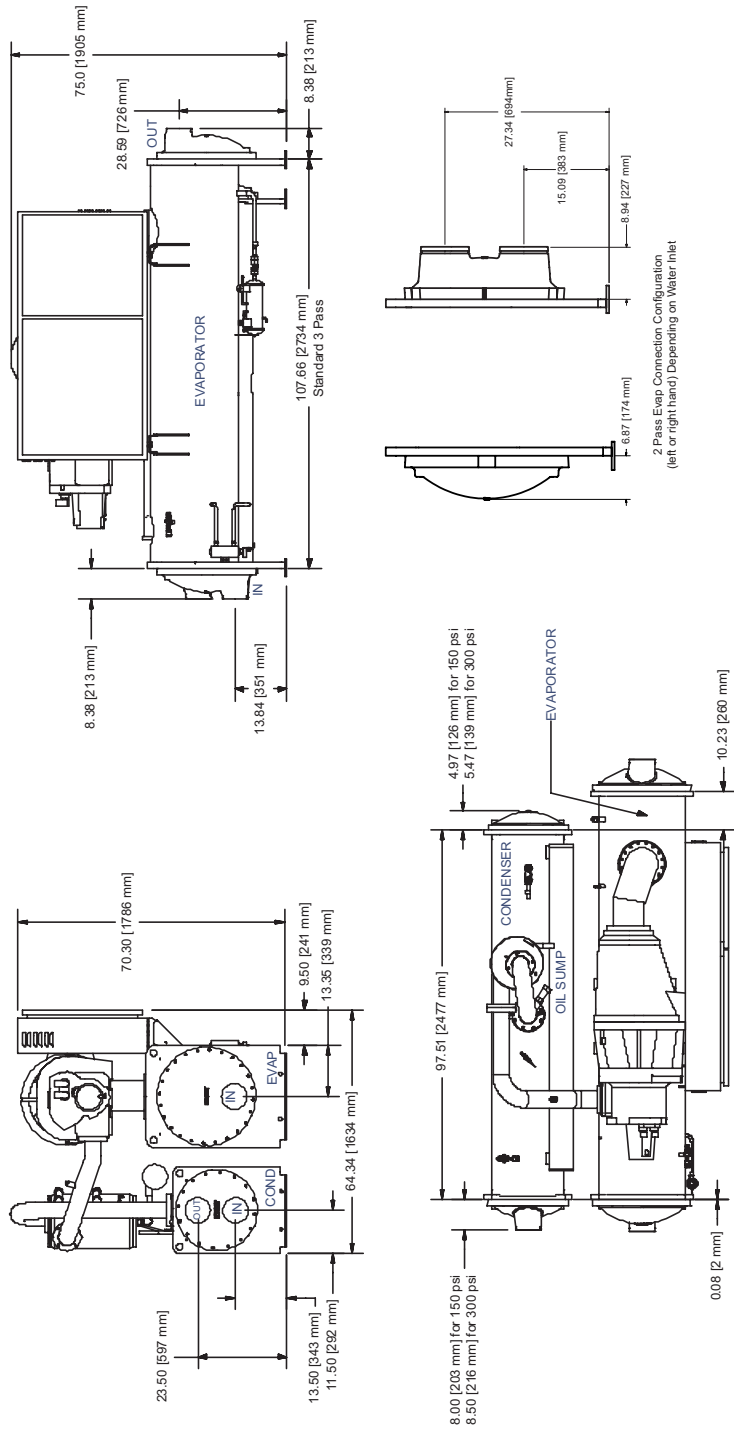

**Figure 9 Condenser and Evaporator Water Connections -BBB**



# Installation Mechanical

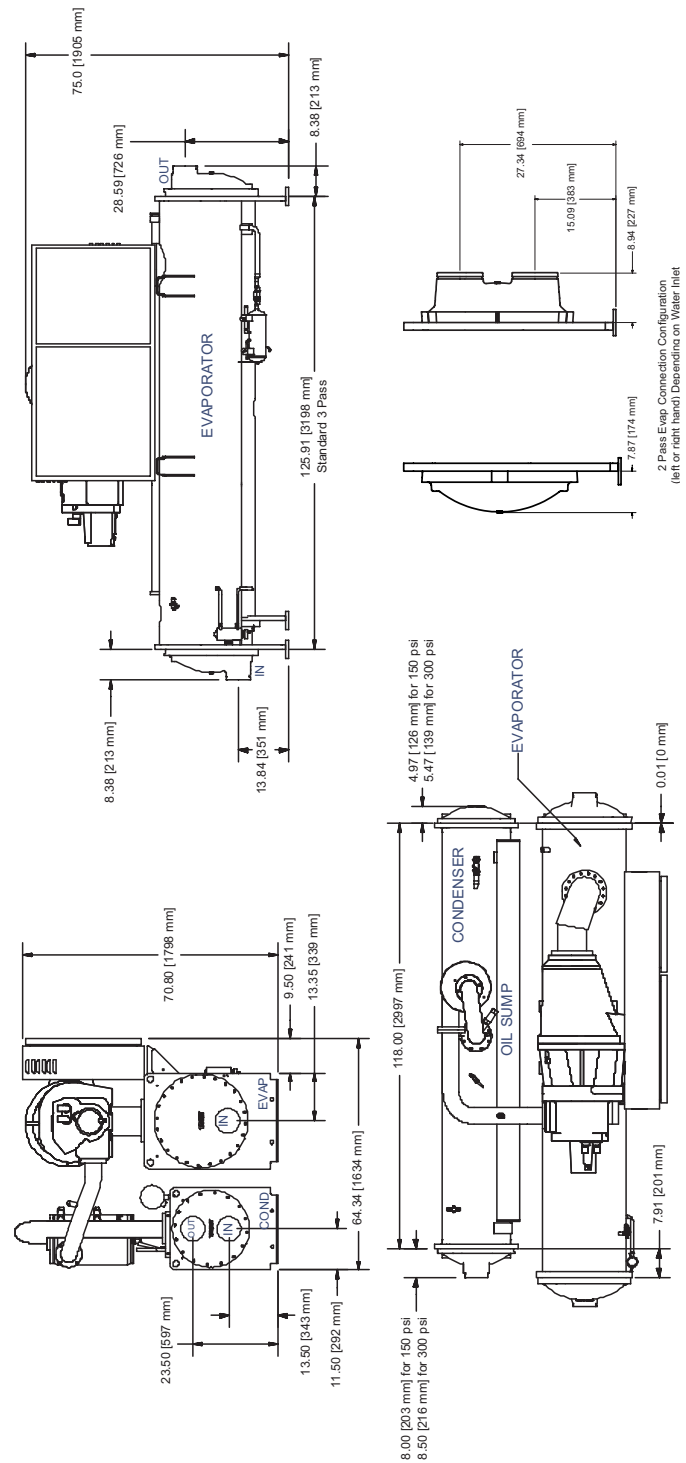
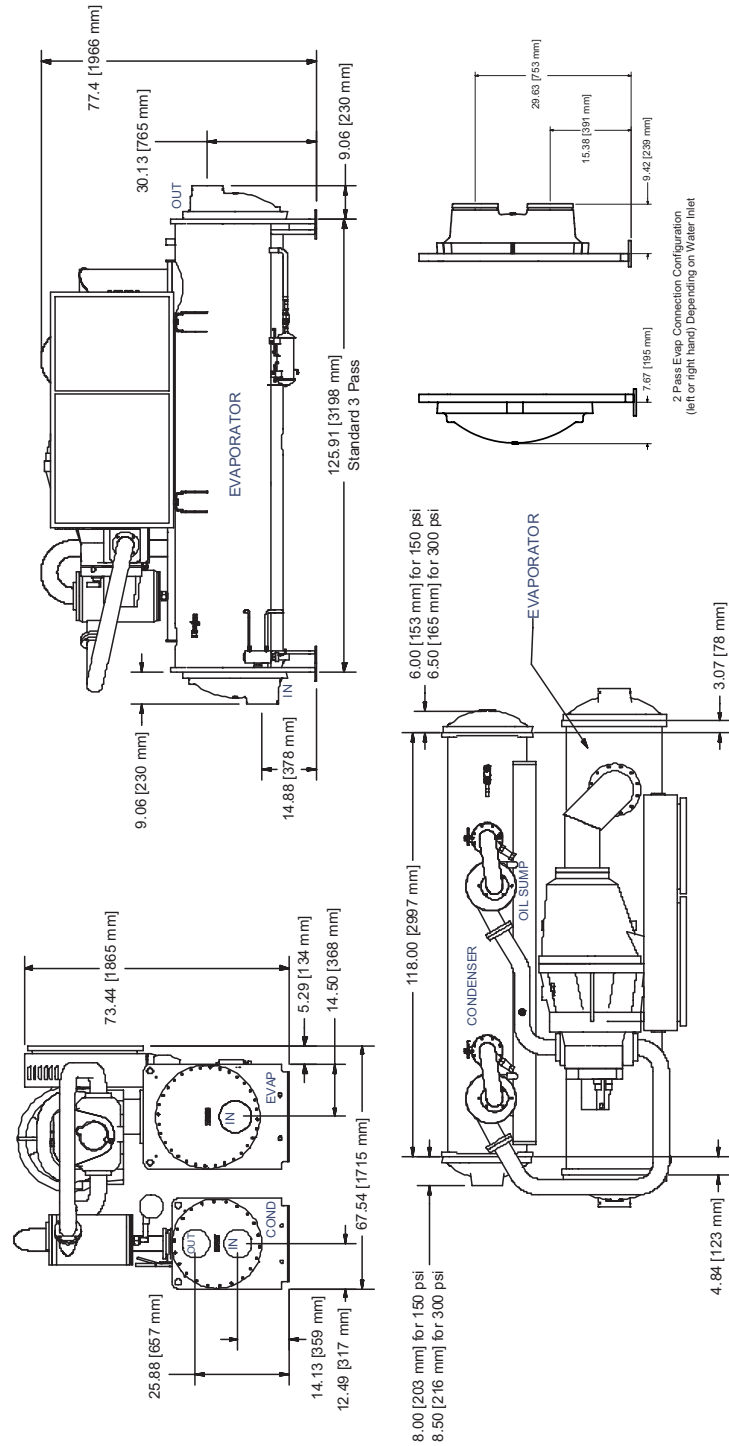

Figure 10 Condenser and Evaporator Water Connections -BCD

# Installation Mechanical



**Figure 11 Condenser and Evaporator Water Connections - CEF**

# Installation Mechanical

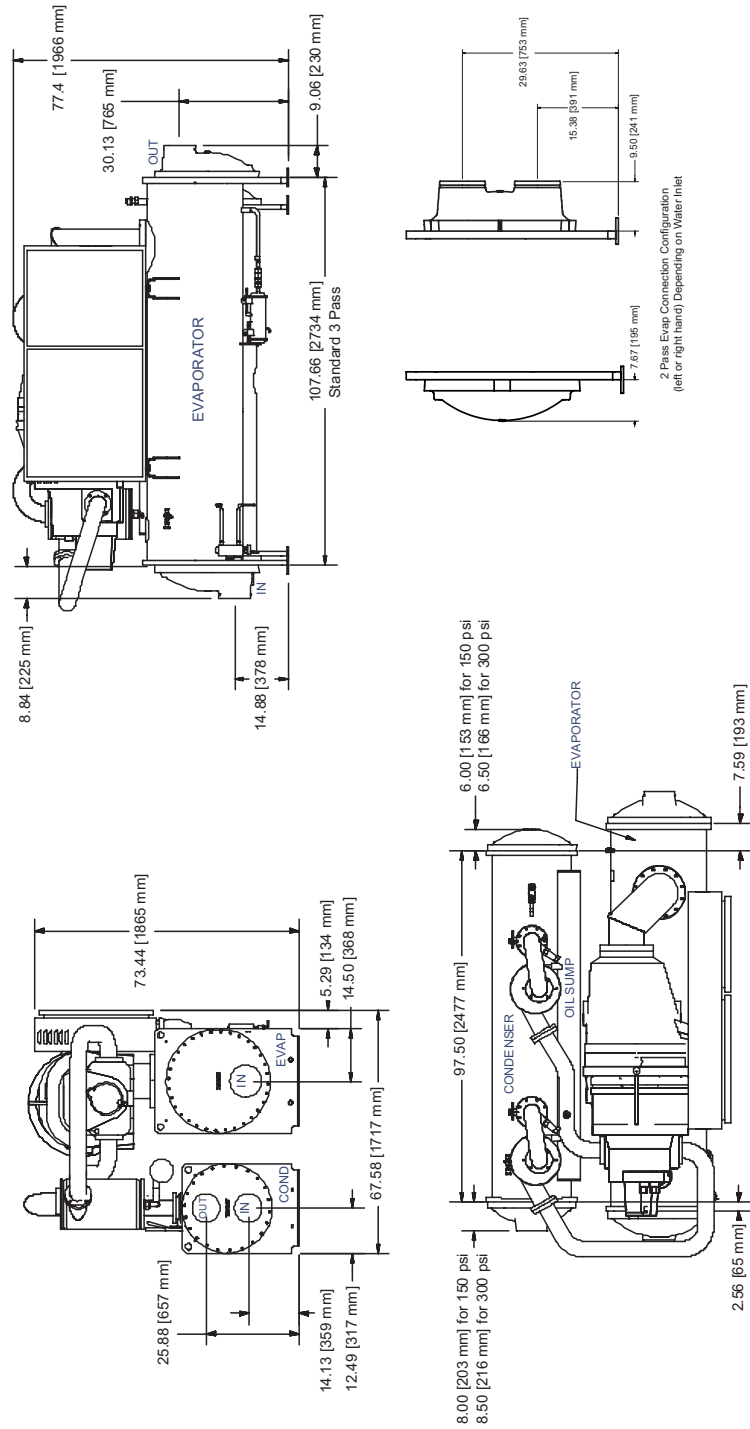

Figure 12 Condenser and Evaporator Water Connections - CDE/DDE/EDE

# Installation Mechanical

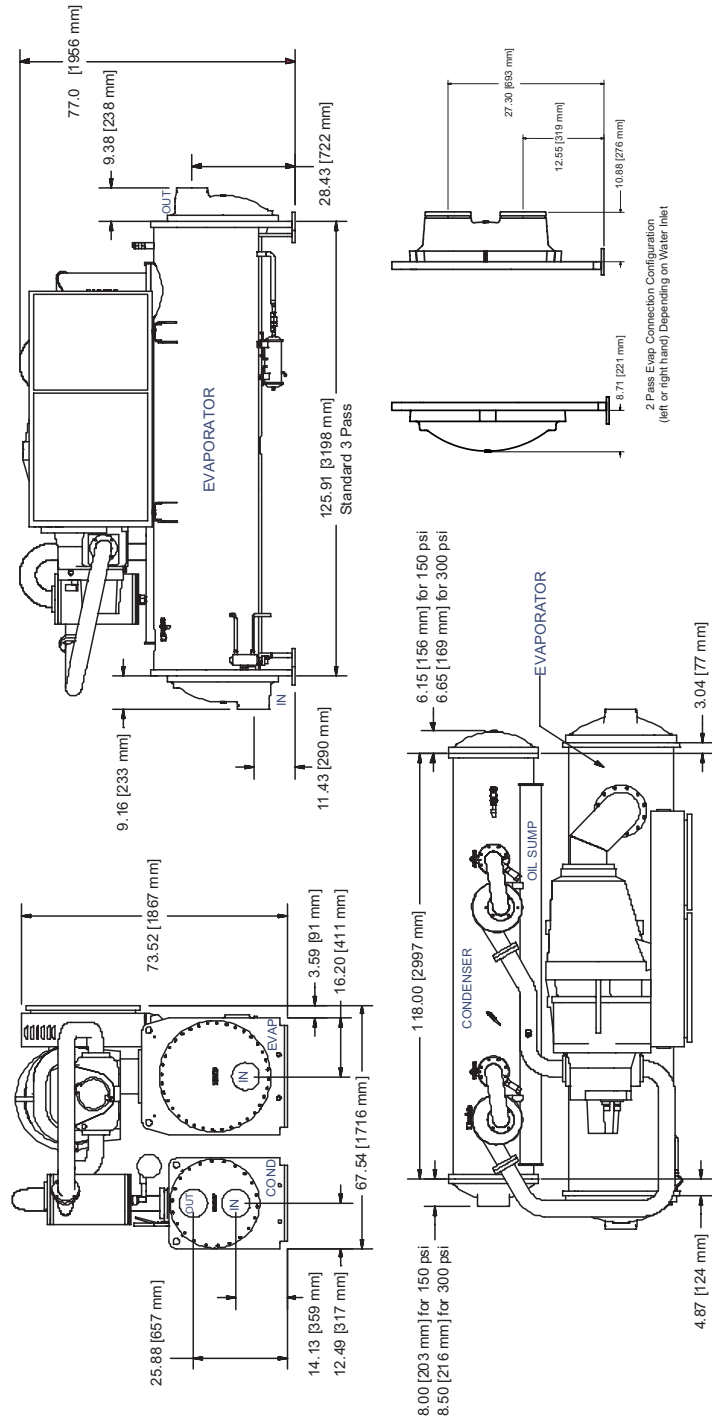

Figure 13 Condenser and Evaporator Water Connections - DFF/EFF/CFF

# Installation Mechanical

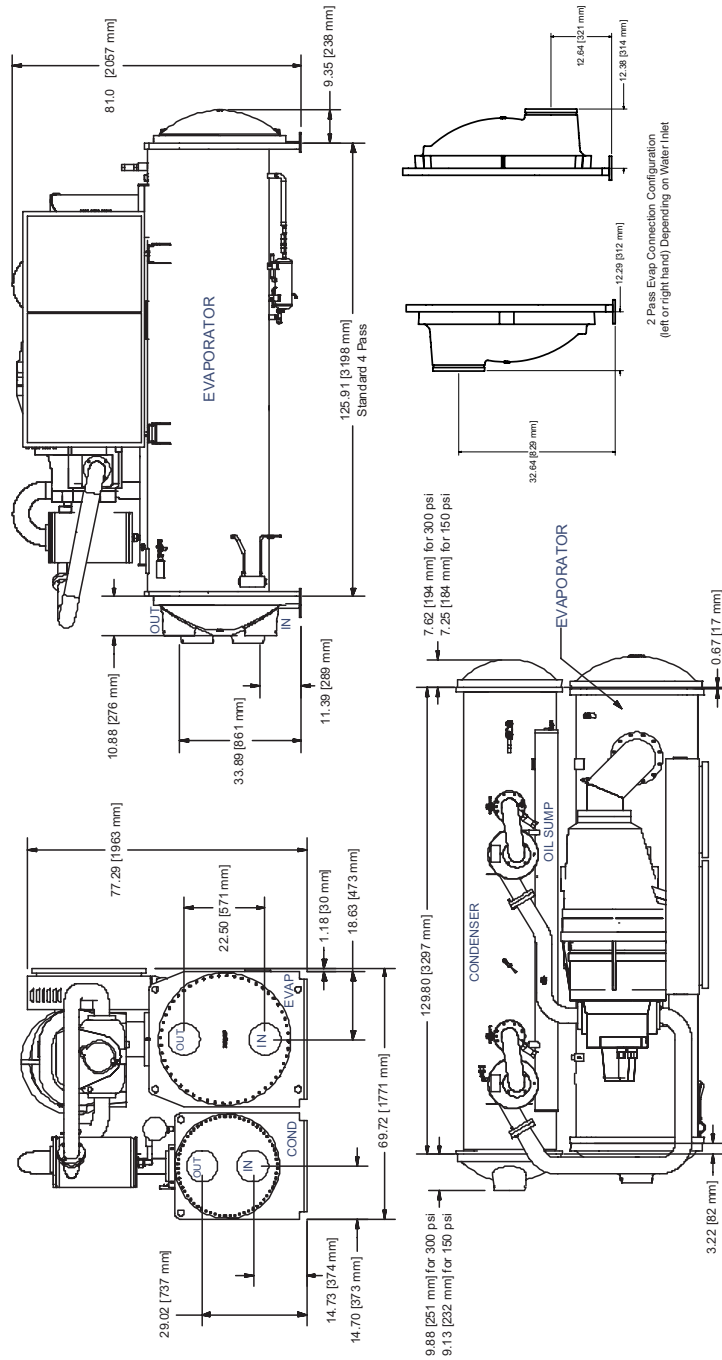

Figure 14 Condenser and Evaporator Water Connections - DGG/EGG



# Installation Mechanical

**Table 10 Evaporator and Condenser Data**

Compress or Frame Code (Digit 6,7 of Model No.)	Evap Shell Code (Digits 14, 15 of Model No.)	Evap. Shell Diameter (in)	Nominal Connector size (NPS)*			Cond Shell Code (Digits 21,22 of Model No.)	Cond. Shell Diameter (in)	Nom. Conn. Size (NPS)*
			2- Pass	3- Pass	4- Pass			2-Pass
E3	D2	26.5	8	8	-	E2	22.0	8
	F2	29.0	8	8	-	E2	22.0	8
	G2	33.5	-	10	8	G1	25.75	8
	G3	33.5	-	10	8	G3	25.75	8
D3	D2	26.5	8	8	-	E2	22.0	8
	F2	29.0	10	8	-	F3	22.0	8
	G2	33.5	-	10	8	G1	25.75	8
	G3	33.5	-	10	8	G3	25.75	8
D2	D2	26.5	8	8	-	E2	22.0	8
	F2	29.0	10	8	-	F3	22.0	8
	G2	33.5	-	10	8	G1	25.75	8
	G3	33.5	-	10	8	G3	25.75	8
D1	D1	26.5	8	8	-	E1	22.0	8
	F1	29.0	10	8	-	F2	22.0	8
	G1	33.5	-	10	8	G1	25.75	8
	G2	33.5	-	10	8	G2	25.75	8
C2	D3	26.5	8	8	-	E3	22.0	8
	D4	26.5	8	8	-	E4	22.0	8
	F2	29.0	10	8	-	F3	22.0	8
C1	D6	26.5	8	8	-	E5	22.0	8
	D5	26.5	8	8	-	E4	22.0	8
	E1	33.5	8	8	-	F1	22.0	8
B2	C2	23.0	-	6	-	D2	18.75	6
	B2	23.0	-	6	-	B2	18.75	6
B1	C1	23.0	-	6	-	D1	18.75	6
	B1	23.0	-	6	-	B1	18.75	6

*Metric Conversion is:*

6 NPS = 150 mm nominal  
 8 NPS = 200 mm nominal  
 10 NPS = 250 mm nominal

# Installation Mechanical

## Water Pressure Drop Data

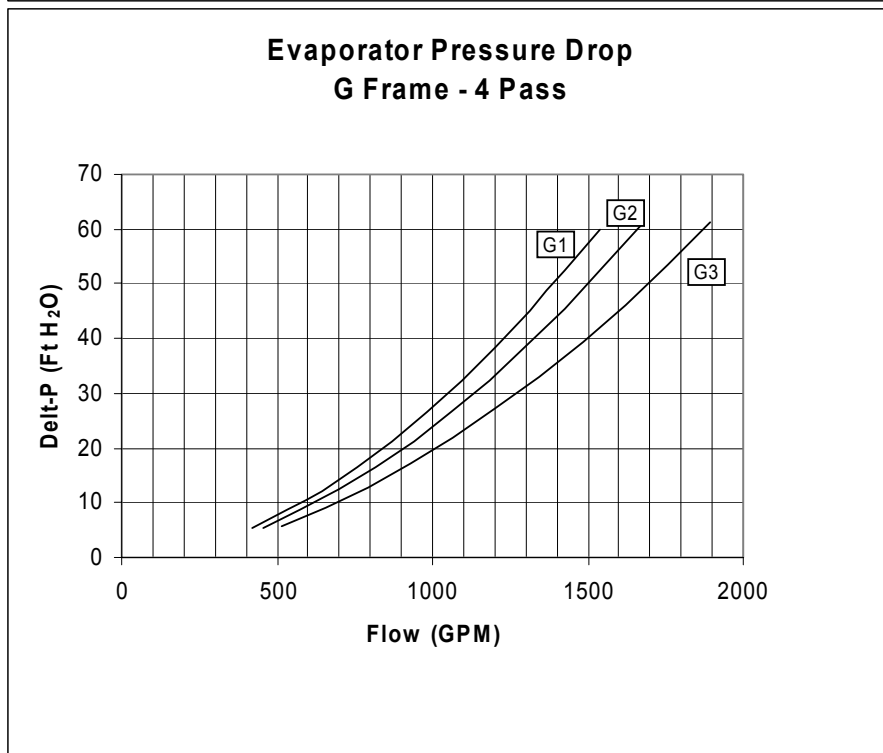
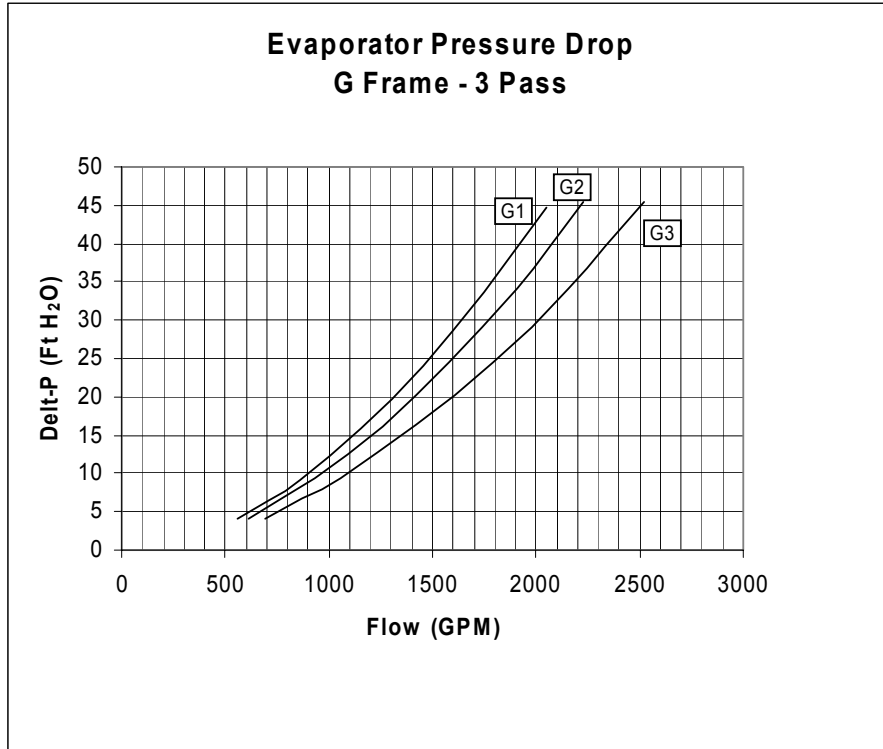

# Installation Mechanical

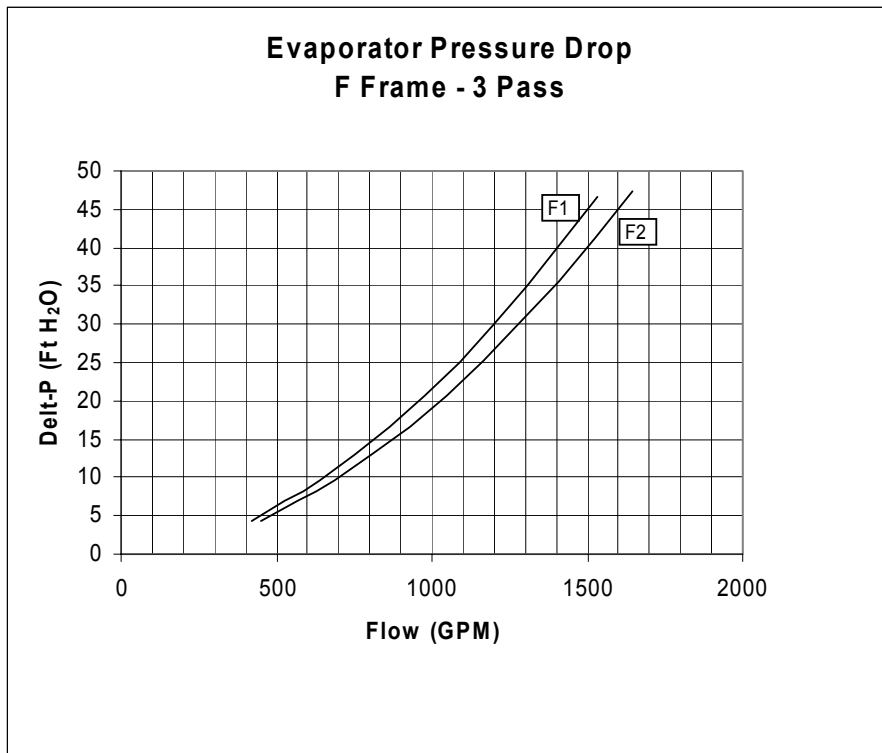
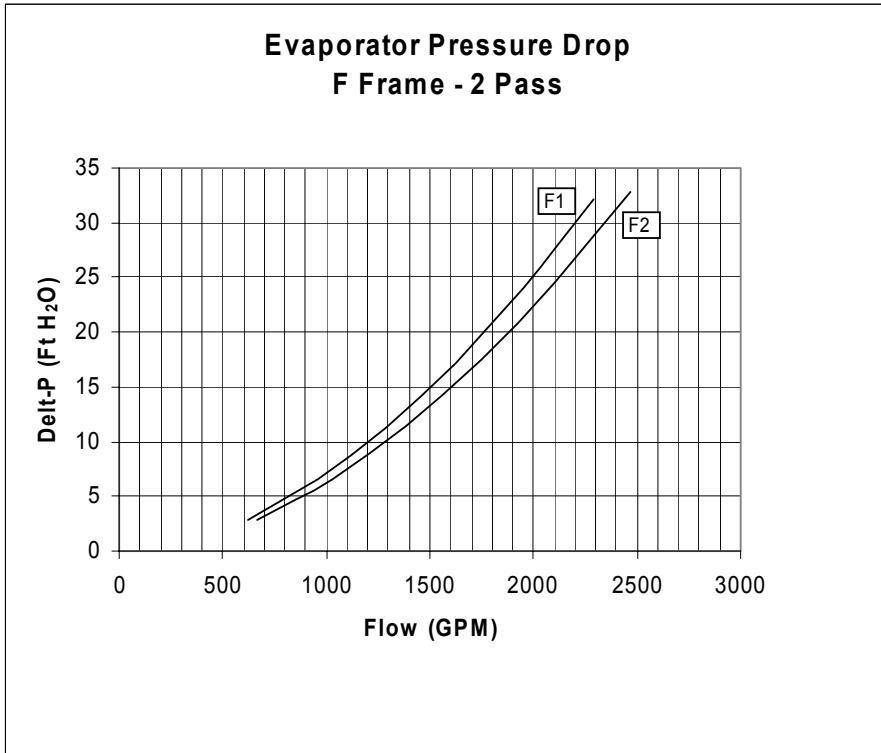



# Installation Mechanical

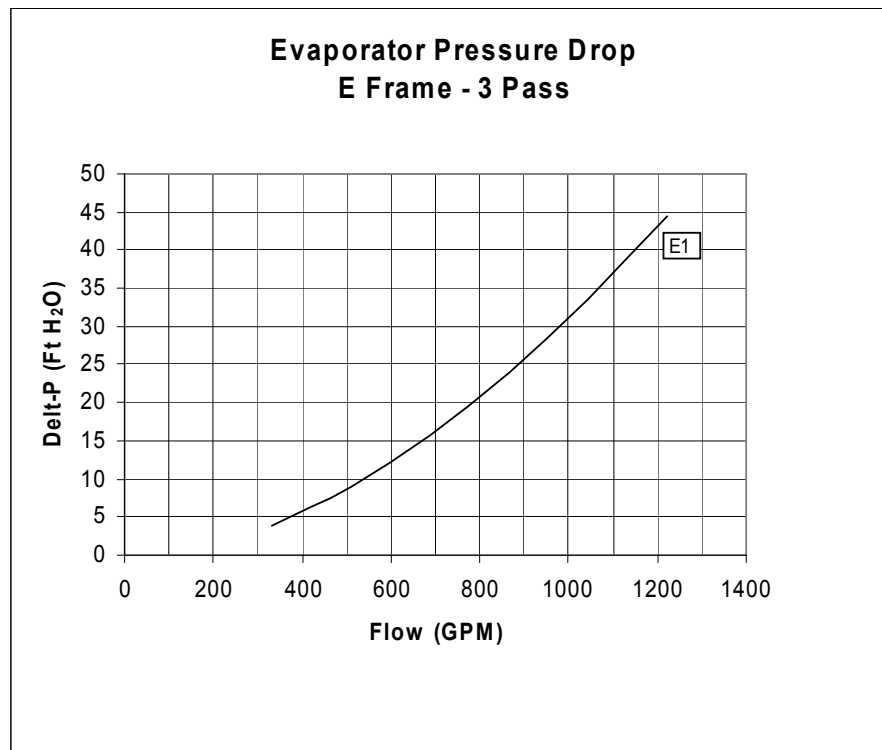
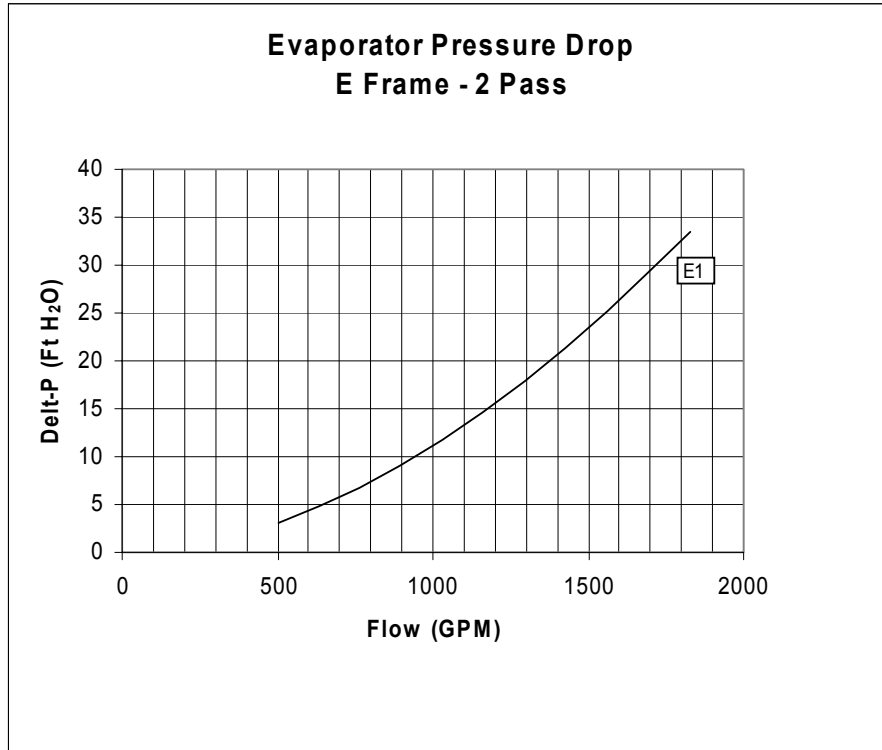

# Installation Mechanical

---

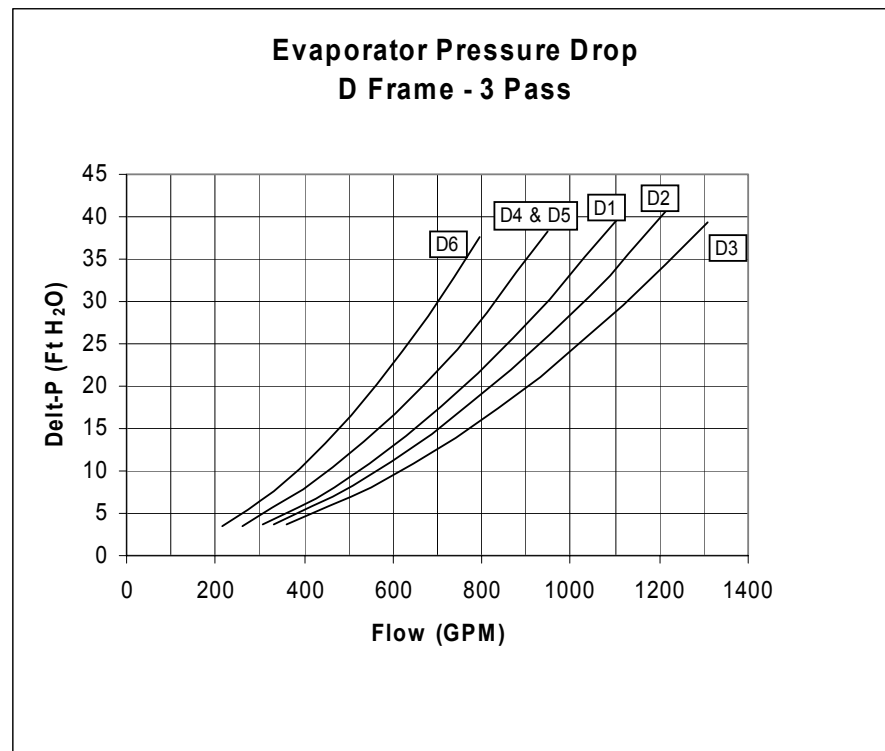
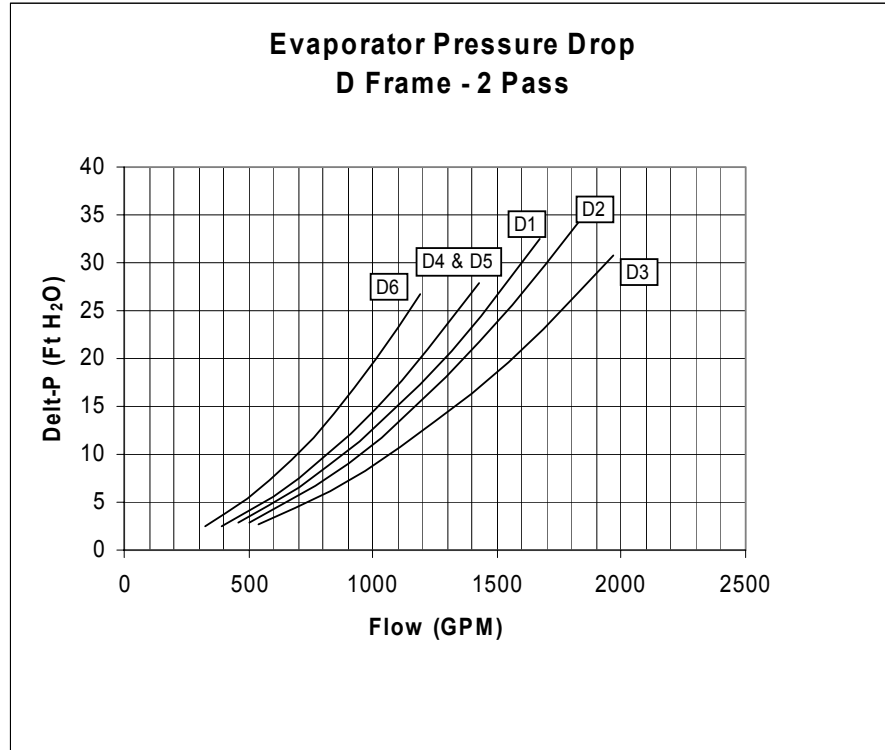

# Installation Mechanical

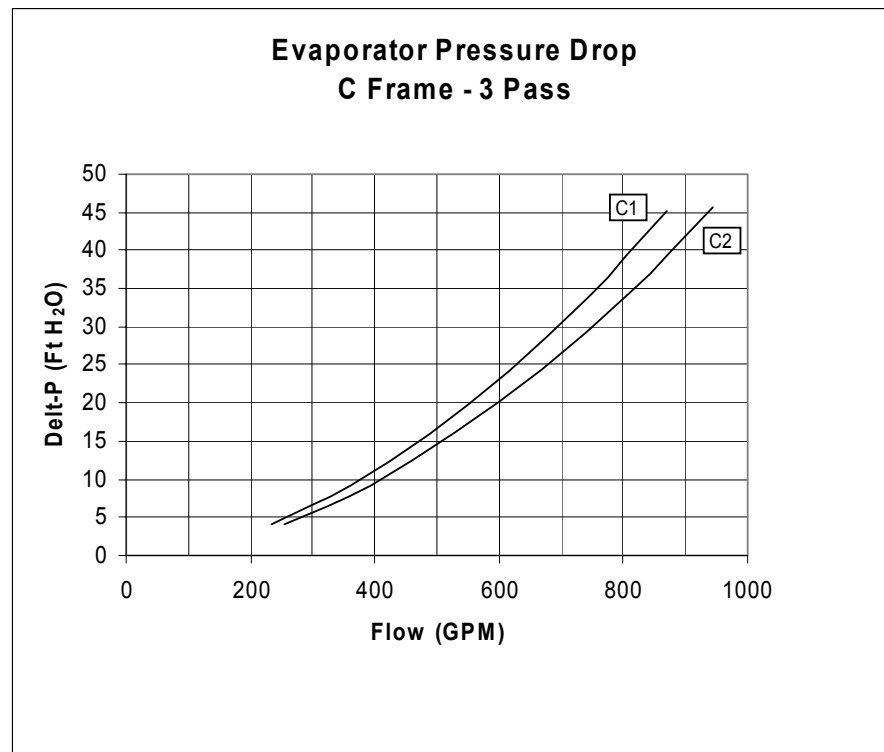
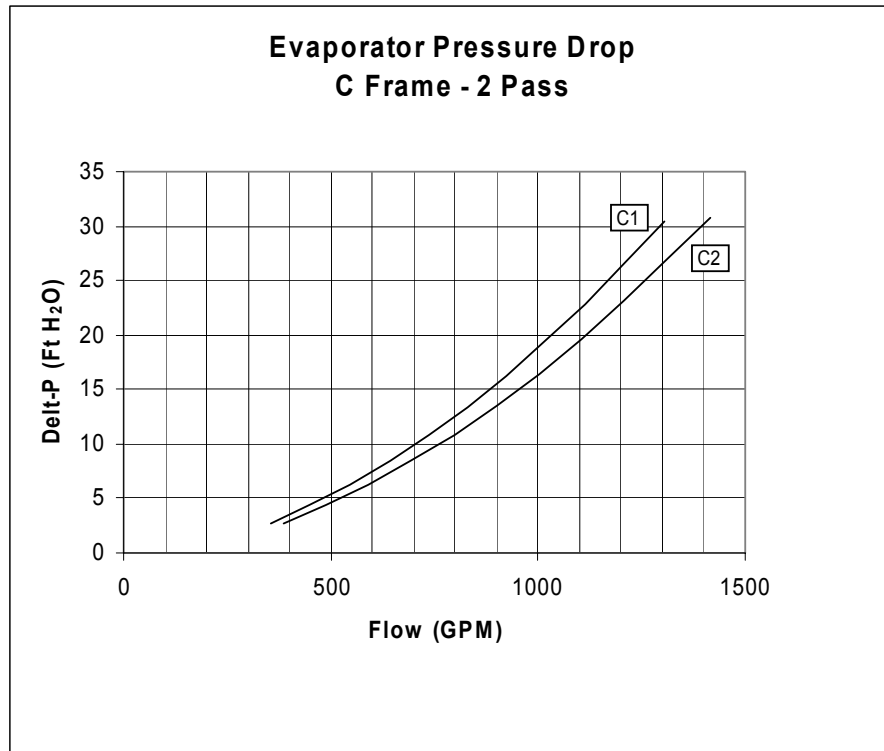

# Installation Mechanical

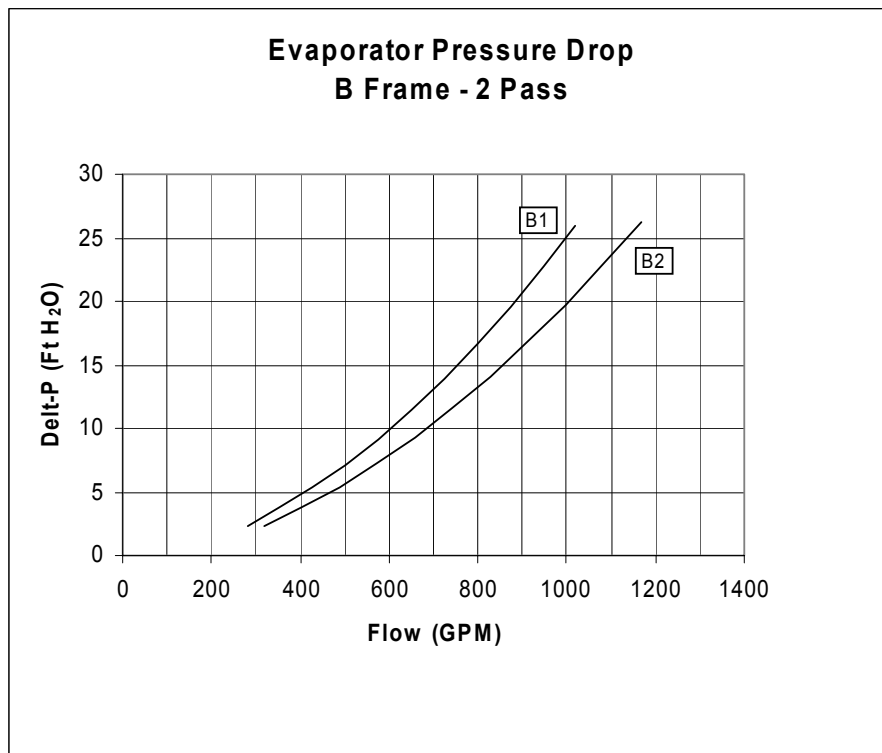
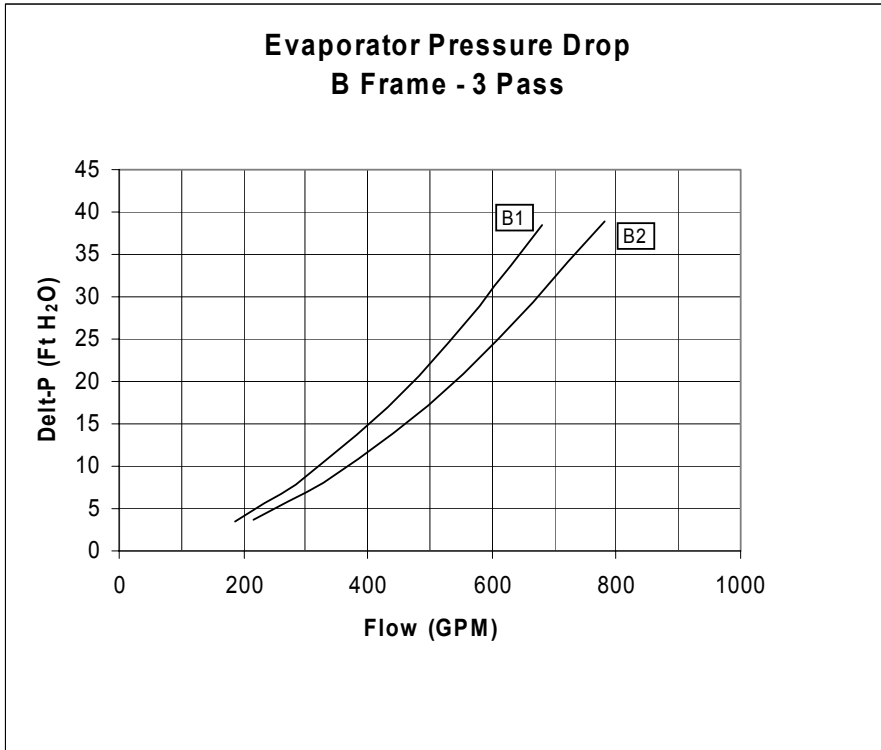

# Installation Mechanical

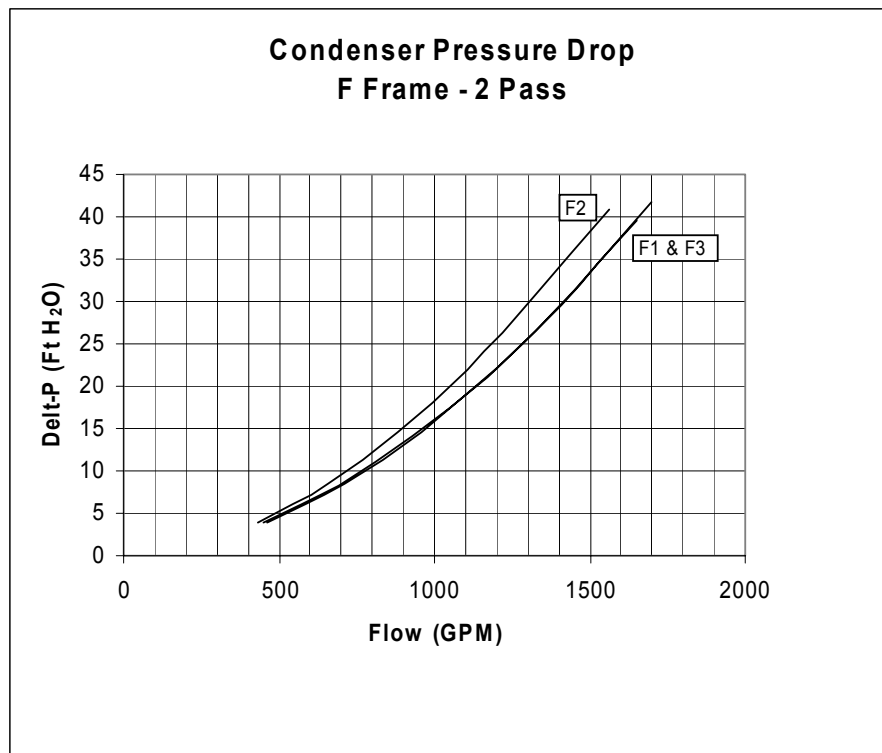
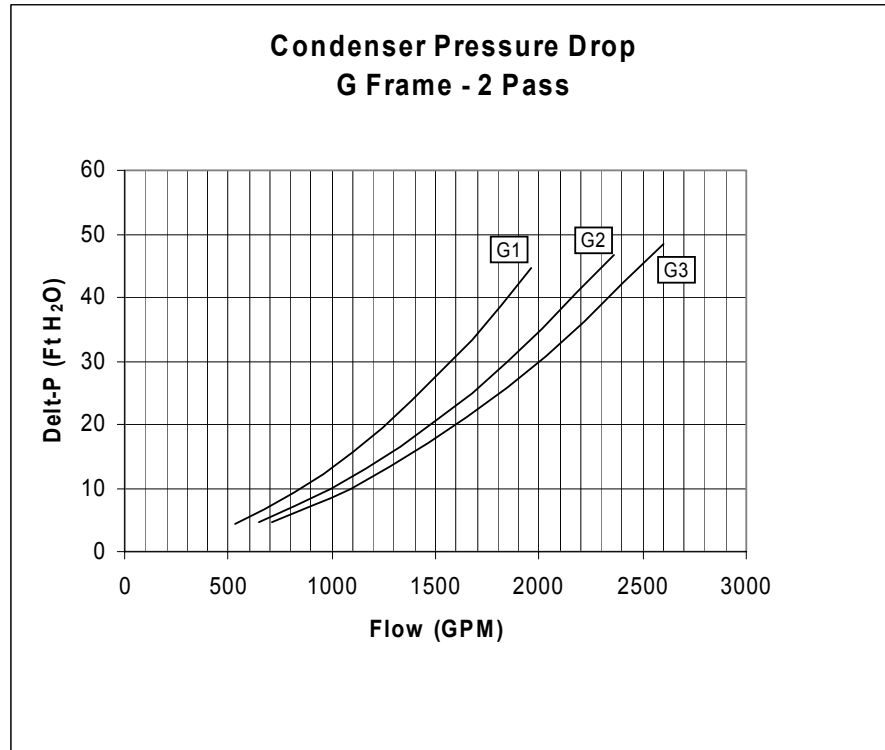

# Installation Mechanical

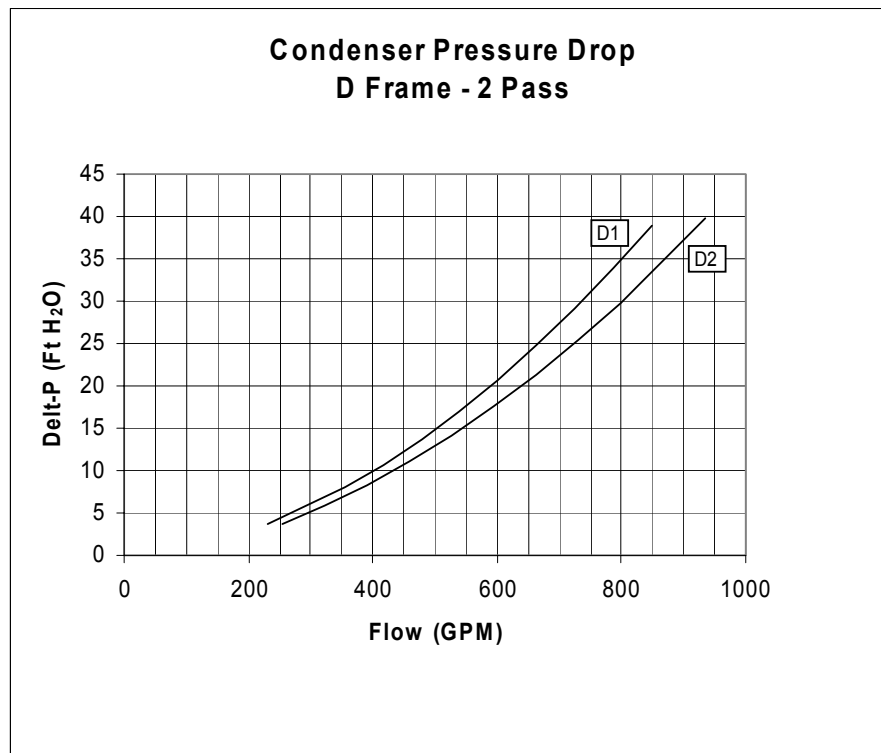
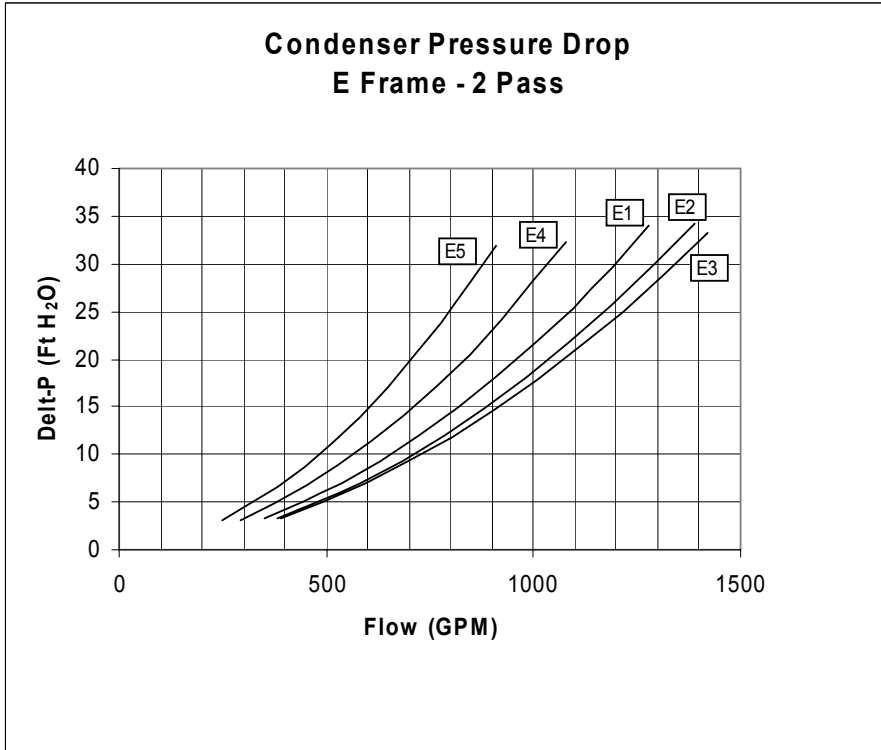

# Installation Mechanical

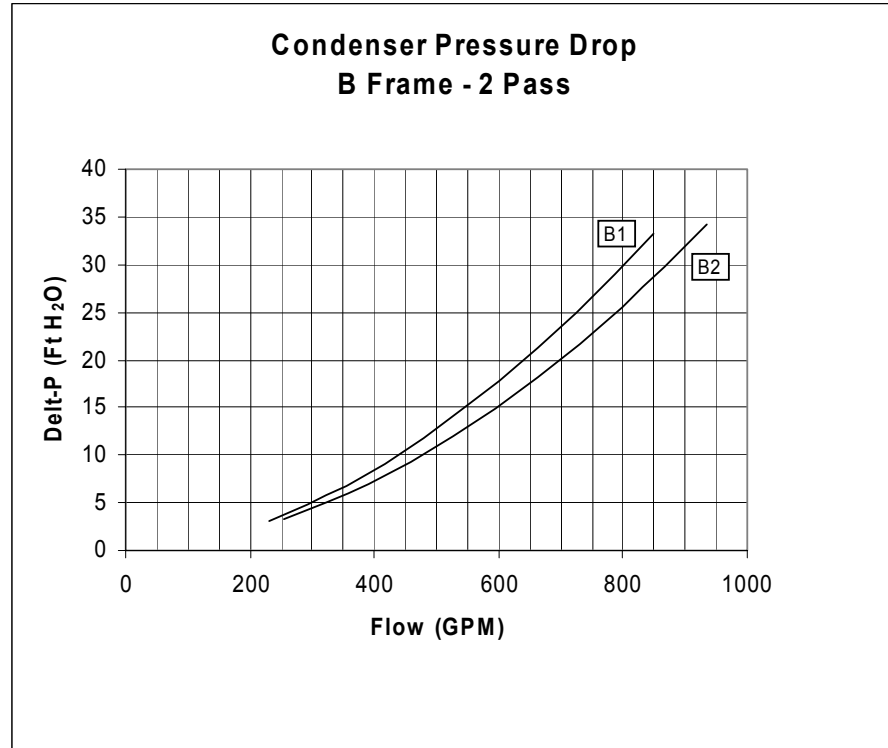

## Making Grooved Pipe Connections

### **CAUTION** Equipment Damage!

**To prevent damage to water piping, do not overtighten connections. To prevent equipment damage, bypass the unit if using an acidic flushing agent.**

*NOTE: Make sure that all piping is flushed and cleaned prior to starting the unit.*

### **Vents and Drains**

Install pipe plugs in evaporator and condenser water box drain and vent connections before filling the water systems.

To drain water, remove vent and drain plugs, install a NPT connector in the drain connection with a shutoff valve and connect a hose to it.

### **Evaporator Piping Components**

*NOTE: Make sure all piping components are between the shutoff valves, so that isolation can be accomplished on both the condenser and the evaporator.*



# Installation Mechanical

---

“Piping components” include all devices and controls used to provide proper water system operation and unit operating safety. These components and their general locations are given below.

## Entering Chilled Water Piping

- Air vents (to bleed air from system)
- Water pressure gauges with shutoff valves
- Pipe unions
- Vibration eliminators (rubber boots)
- Shutoff (isolation) valves
- Thermometers
- Cleanout tees
- Pipe strainer
- Flow switch

## Leaving Chilled Water Piping

- Air vents (to bleed air from system)
- Water pressure gauges with shutoff valves
- Pipe unions
- Vibration eliminators (rubber boots)
- Shutoff (isolation) valves
- Thermometers
- Cleanout tees
- Balancing valve
- Pressure relief valve

## CAUTION Evaporator Damage!

**To prevent evaporator damage, do not exceed 150 psig (10.3 bar) evaporator water pressure for standard water boxes. Maximum pressure for high pressure water boxes is 300 psig (20.7 bar). Refer to digit 14 of the Model No. To prevent tube damage, install a strainer in the evaporator water inlet piping. To prevent tube corrosion, ensure that the initial water fill has a balanced pH.**

## Condenser Piping Components

“Piping components” include all devices and controls used to provide proper water system operation and unit operating safety. These components and their general locations are given below.

### Entering condenser water piping.

- Air vents (to bleed air from system)
- Water pressure gauges with shutoff valves



## Installation Mechanical

---

- Pipe unions
- Vibration eliminators (rubber boots)
- Shutoff (isolation) valves. One per each pass
- Thermometers
- Cleanout tees
- Pipe strainer
- Flow switch

### **Leaving condenser water piping.**

- Air vents (to bleed air from system)
- Water pressure gauges with shutoff valves
- Pipe unions
- Vibration eliminators (rubber boots)
- Shutoff (isolation) valve - one per each pass
- Thermometers
- Cleanout tees
- Balancing valve
- Pressure relief valve.

## **CAUTION**

### **Condenser Damage!**

**To prevent condenser damage, do not exceed 150 psig (10.3 bar) water pressure for standard water boxes. Maximum pressure for high pressure water boxes is 300 psig (20.7 bar). Refer to digit 18 of the Model No. To prevent tube damage, install a strainer in condenser water inlet piping. To prevent tube corrosion, ensure that the initial water fill has a balanced pH.**

### **Condenser Water Regulating Valve**

The Condenser Head Pressure Control Option provides for a 0-10VDC (maximum range - a smaller range is adjustable) output interface to the customer's condenser water flow device. The condenser water flow device is typically a large butterfly type (6" or 8") automatic valve for 200 to 400 Ton chillers.

The following guidelines must be met in order to ensure adequate oil circulation throughout the system.

- The RTHD must maintain a 23 psid system pressure differential at all load conditions in order to ensure adequate oil circulation.
- The entering condenser water temperature must be above 55°F (12.8°C) or between 45°F (7.2°C) and 55°F (12.8°C) with a 1°F temperature rise per minute to 55°F (12.8°C).



## Installation Mechanical

---

- Condenser leaving water temperature must be 17°F degrees higher than evaporator leaving water temperature within 2 minutes of startup. A 25°F differential must be maintained thereafter.

If the above guidelines cannot be met, then some form of tower water control must be used.

### Condenser Water Regulating Valve Adjustment

A separate TechView Settings Menu tab entitled "Condenser Head Pressure Control - Setup" that is only visible if the configuration is selected, contain the following settings and manual overrides for user adjustments and commissioning all under one tab:

- "Off State" Output Command (0-10 Vdc 0.1 volt increments, Default 2.0 Vdc)
- Output Voltage @ Desired Minimum Flow (Adj: 0 to 10.0 in 0.1 volt increments, Default 2.0 Vdc)
- Desired Minimum Flow (Adj: 0- 100% of full flow in 1% intervals, Default 20%)
- Output Voltage @ Desired Maximum Flow (Adj: 0 to 10.0 in .1 volt increments (or finer), Default 10 Vdc)
- Actuator Stroke Time (Min to Max Range Time) (Adj: 1 to 1000 seconds, in 1 second increments, Default 30s)
- Damping Coefficient (adj: 0.1 to 1.8 , in .1 increments, Default .5)
- Head Pressure Control Override (enumeration of: disabled (auto), "off" state, minimum, maximum (100%),) default :disabled (auto). When this setting is in "disabled (auto)"
- Condenser Water Pump Prerun Time ( )

### Water Treatment

#### CAUTION

#### Proper Water Treatment!

**The use of untreated or improperly treated water in a RTHD may result in scaling, erosion, corrosion, algae or slime. It is recommended that the services of a qualified water treatment specialist be engaged to determine what water treatment, if any, is required. The Trane Company assumes no responsibility for equipment failures which result from untreated or improperly treated water, or saline or brackish water.**

Using untreated or improperly treated water in these units may result in inefficient operation and possible tube damage. Consult a qualified water treatment specialist to determine whether treatment is needed.

# Installation Mechanical

## Water Pressure Gauges and Thermometers

Install field-supplied thermometers and pressure gauges (with manifolds, whenever practical) as shown in Figure 15. Locate pressure gauges or taps in a straight run of pipe; avoid placement near elbows, etc. Be sure to install the gauges at the same elevation on each shell if the shells have opposite-end water connections.

To read manifolded water pressure gauges, open one valve and close the other (depending upon the reading desired). This eliminates errors resulting from differently calibrated gauges installed at unmatched elevations.

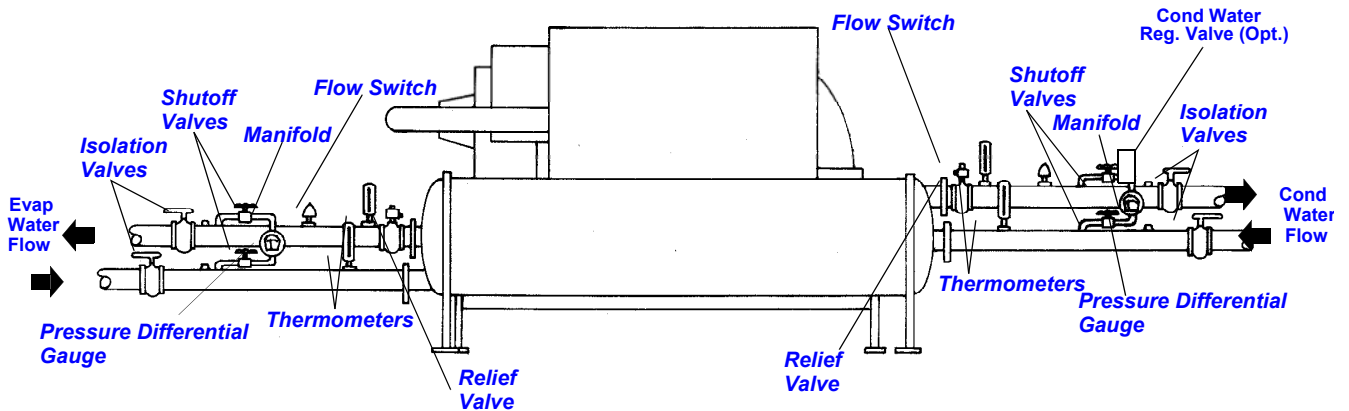

Refer to *Trane Engineering Bulletin -Series R® Chiller Sound Ratings and Installation Guide* for sound-sensitive applications.

Figure 15 Typical Thermometer, Valving, and Manifold Pressure Gauge Set-up

## Water Pressure Relief Valves

### CAUTION Shell Damage!

**Install a pressure relief valve in both evaporator and condenser water systems. Failure to do so may result in shell damage.**

Install a water pressure relief valve in one of the condenser and one of the evaporator water box drain connections or on the shell side of any shutoff valve. Water vessels with close-coupled shutoff valves have a high potential for hydrostatic pressure buildup on a water temperature increase. Refer to applicable codes for relief valve installation guidelines.

## Flow Sensing Devices

The installer **must** provide flow switches or differential pressure switches with pump interlocks to sense system water flow. Flow switch locations are schematically shown in Figure 15.

To provide chiller protection, install and wire flow switches in series with the water pump interlocks, for both chilled water and condenser water circuits (refer to the Installation Electrical section). Specific connections and schematic wiring diagrams are shipped with the unit.



## Installation Mechanical

---

Flow switches must stop or prevent compressor operation if either system water flow drops off below the required minimum shown on the pressure drop curves. Follow the manufacturer's recommendations for selection and installation procedures. General guidelines for flow switch installation are outlined below.

- Mount the switch upright, with a minimum of 5 pipe diameters straight, horizontal run on each side.
- Do not install close to elbows, orifices or valves.

*NOTE: The arrow on the switch must point in the direction of the water flow.*

- To prevent switch fluttering, remove all air from the water system

*NOTE: The CH530 provides a 6-second time delay on the flow switch input before shutting down the unit on a loss-of-flow diagnostic. Contact a qualified service organization if nuisance machine shutdowns persist.*

- Adjust the switch to open when water flow falls below nominal. Refer to the General Data table in Section 1 for minimum flow recommendations for specific water pass arrangements. Flow switch contacts are closed on proof of water flow.

### Refrigerant Pressure Relief Valve Venting

#### **⚠ WARNING** **Hazardous Gases!**

**Consult local regulations for any special relief line requirements. Refrigerant vented into a confined equipment room could displace available oxygen to breathe, causing possible asphyxiation or other serious health risks. Failure to follow these recommendations could result in death or serious injury.**

*NOTE: Vent pipe size must conform to the ANSI/ASHRAE Standard 15 for vent pipe sizing. All federal, state, and local codes take precedence over any suggestions stated in this manual.*

All relief valve venting is the responsibility of the installing contractor.

All RTHD units use evaporator, compressor, and condenser pressure relief valves (Figure 16) that must be vented to the outside of the building.

Relief valve connection sizes and locations are shown in the unit submittals. Refer to local codes for relief valve vent line sizing information.

#### **Caution** **Equipment Damage!**

**Do not exceed vent piping code specifications. Failure to comply with specifications may result in capacity reduction, unit damage and/or relief valve damage.**

# Installation Mechanical

Relief valve discharge setpoints and capacities rates are given in [Table 11](#). Once the relief valve has opened, it will reclose when pressure is reduced to a safe level.

*NOTE: Once opened, relief valves may have tendency to leak and must be replaced.*

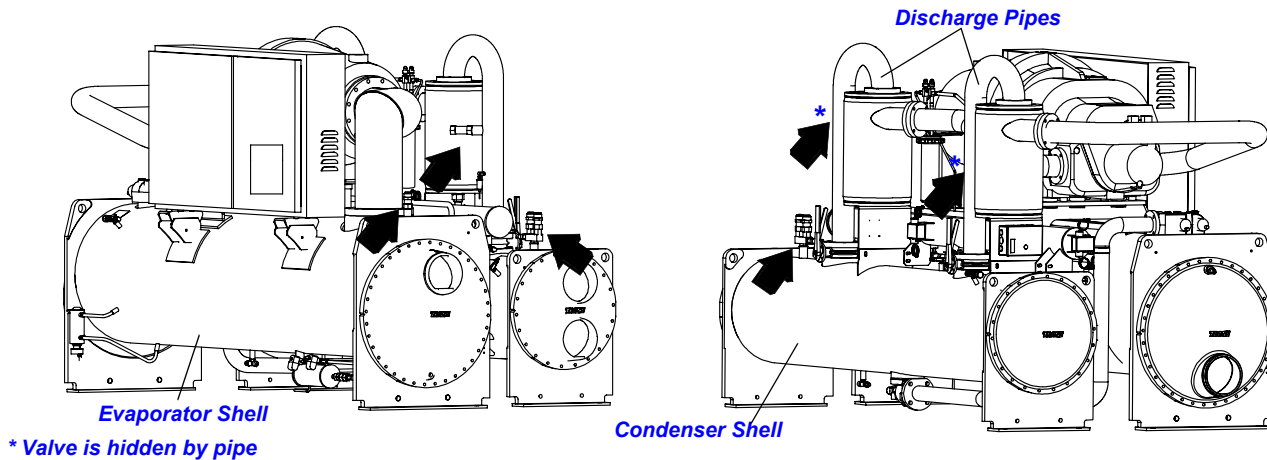

**Figure 16 Relief Valve Location**

Pressure relief valve discharge capacities will vary with shell diameter and length and also compressor displacement. Discharge venting capacity should be calculated as required by ASHRAE Standard 15-94. Do not adjust relief valve setting in the field.

**Table 11 Pressure Relief Valve Data**

Valve Location	Discharge Setpoint (psi)	Number of Valves	Rated Capacity per Relief Valve (lba/min.)	Field Connection Pipe Size (in NPT)	Factory Shell Side Connection(in)
Evap - B1	200	1	48.0	1	1-5/16 -12
Evap - B2	200	1	48.0	1	1-5/16 -12
Evap -B3	200	1	48.0	1	1-5/16 -12
Evap -C1	200	1	48.0	1	1-5/16 -12
Evap - C2	200	1	48.0	1	1-5/16 -12
Evap - D1	200	1	48.0	1	1-5/16 -12
Evap - D2	200	1	48.0	1	1-5/16 -12
Evap - D3	200	1	48.0	1	1-5/16 -12
Evap - D4	200	1	48.0	1	1-5/16 -12
Evap - D5	200	1	48.0	1	1-5/16 -12
Evap - D6	200	1	48.0	1	1-5/16 -12
Evap - E1	200	1	48.0	1	1-5/16 -12
Evap - F1	200	1	48.0	1	1-5/16 -12
Evap - F2	200	1	48.0	1	1-5/16 -12
Evap - G1	200	1	78.8	1-1/4	1-5/8 - 12
Evap - G2	200	1	78.8	1-1/4	1-5/8 - 12



# Installation Mechanical

**Table 11 Pressure Relief Valve Data**

Valve Location	Discharge Setpoint (psi)	Number of Valves	Rated Capacity per Relief Valve (lba/min.)	Field Connection Pipe Size (in NPT)	Factory Shell Side Connection(in)
Evap - G3	200	1	78.8	1-1/4	1-5/8 - 12
Cond - B1	200	2	48.0	1	1-5/16 -12
Cond - B2	200	2	48.0	1	1-5/16 -12
Cond - D1	200	2	48.0	1	1-5/16 -12
Cond - D2	200	2	48.0	1	1-5/16 -12
Cond - E1	200	2	48.0	1	1-5/16 -12
Cond - E2	200	2	48.0	1	1-5/16 -12
Cond - E3	200	2	48.0	1	1-5/16 -12
Cond - E4	200	2	48.0	1	1-5/16 -12
Cond - E5	200	2	48.0	1	1-5/16 -12
Cond - F1	200	2	48.0	1	1-5/16 -12
Cond - F2	200	2	48.0	1	1-5/16 -12
Cond - F3	200	2	48.0	1	1-5/16 -12
Cond - G1	200	2	48.0	1	1-5/16 -12
Cond - G2	200	2	48.0	1	1-5/16 -12
Cond - G3	200	2	48.0	1	1-5/16 -12
Comp - B1/B2*	200	2	78.8	1-1/4	1-5/8 - 12
Comp - C1/C2*	200	3	78.8	1-1/4	1-5/8 - 12
Comp - D1/D2/D3*	200	3	78.8	1-1/4	1-5/8 - 12
Comp -E3*	200	3	78.8	1-1/4	1-5/8 - 12

\* Only used with isolation valve option

## Thermal Insulation

All RTHD units are available with optional factory installed thermal insulation. If the unit is not factory insulated, install insulation over the areas shaded in [Figure 17](#). Refer to [Table 12](#) for types and quantities of insulation required.

*NOTE: Liquid line filter, refrigerant charging valves, water temperature sensors, drain and vent connections when insulated must remain accessible for service.*

*NOTE: Use only water-base latex paint on factory-applied insulation. Failure to do so may result in insulation shrinkage.*

*NOTE: Units in environments with higher humidity or very low leaving water temperature may require thicker insulation*

# Installation Mechanical

---

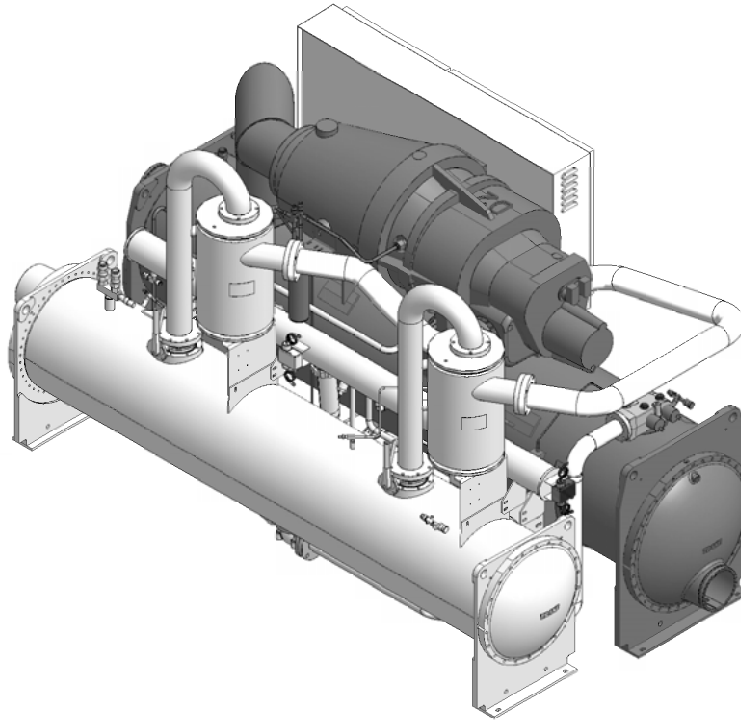

**Figure 17** Typical RTHD Insulation Requirements

**Table 12** Recommended Insulation Types

Location	Type	Sq. Feet
Evaporator	3/4" wall	90
Compressor	3/4" wall	25
All components and piping on low side of system (gas pump, return oil line, filter from pump)	3/4" wall	160



# Installation Mechanical

---





# Installation Electrical

---

## General Recommendations

For proper electrical component operation, do not locate the unit in areas exposed to dust, dirt, corrosive fumes, or excessive humidity. If any of these conditions exist, corrective action must be taken.

## **⚠ WARNING**

### **Hazardous Voltage!**

**Disconnect all electric power, including remote disconnects and discharge all motor start/run capacitors before servicing. Follow proper lockout/tagout procedures to ensure the power cannot be inadvertently energized. Verify with an appropriate voltmeter that all capacitors have discharged. Failure to disconnect power and discharge capacitors before servicing could result in death or serious injury.**

All wiring must comply with local and National Electric Codes. Minimum circuit ampacities and other unit electrical data is on the unit nameplate. See the unit order specifications for actual electrical data. Specific electrical schematics and connection diagrams are shipped with the unit.

Typical wiring diagrams are in the back of this manual.

## **CAUTION**

### **Use Copper Conductors Only!**

**Unit terminals are not designed to accept other types of conductors. Failure to use copper conductors may result in equipment damage.**

Do not allow conduit to interfere with other components, structural members or equipment. All conduit must be long enough to allow compressor and starter removal.

*NOTE: To prevent control malfunctions, do not run low voltage wiring (<30V) in conduit with conductors carrying more than 30 volts.*

### **Power Supply Wiring**

Model RTHD chillers are designed according to NEC Article 310-15; therefore, all power supply wiring must be sized and selected accordingly by the project engineer.

For a complete discussion on the use of conductors, see Trane Engineering Bulletin EB-MSCR-40.

Refer to Trane Engineering Bulletin CTV-EB-93 for power wire sizing.

### **Water Pump Power Supply**

Provide power supply wiring with fused disconnect for both the chilled water and condenser water pumps.



# Installation Electrical

## Electrical Panel Power Supply

Power supply wiring instructions for the starter/control panel are:

1. Run line voltage wiring in conduit to access opening(s) on starter/control panel or pull-box. See CTV-EB-93 for wire sizing and selection information and refer to [Table 13](#) that show typical electrical connection sizes and locations. Always refer to submittal information for your actual unit specifications.

**Table 13 Wire Selection Chart for Starter Panels**

Min. Wire Size Copper 75°C	Supply Leads for All Starters (0 - 2000 Volts)						
	1 Conduit 3 Wire	1 Conduit 6 Wire	1 Conduit 9 Wire	2 Conduits 6 Wire	2 Conduits 12 Wire	3 Conduits 9 Wire	4 Conduits 12 Wire
8	40	*	*	*	*	*	*
6	52	*	*	*	*	*	*
4	68	*	*	*	*	*	*
3	60	*	*	*	*	*	*
2	92	*	*	*	*	*	*
1	104	*	*	*	*	*	*
0	120	192	252	360	384	360	480
00	140	224	294	420	448	420	560
000	160	256	336	480	512	480	640
0000	184	294	386	552	589	552	736
250	204	326	428	612	653	612	816
300	228	356	479	684	730	684	912
350	248	397	521	744	794	744	992
400	268	429	563	804	858	804	1072
500	304	486	638	912	973	912	1216

Conductors to the starter and motor connected in parallel (electrically joined at both ends to form a single conductor) must be sized 0 (1/0) or larger per NEC 310-4. Each phase must be equally represented in each conduit.

# Installation Electrical

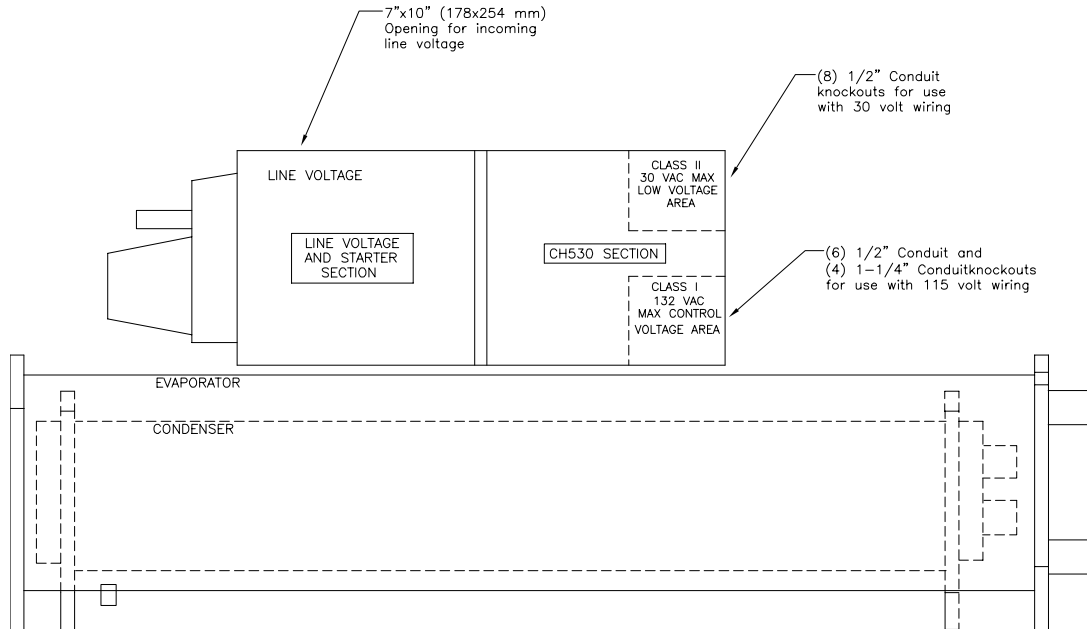

Figure 18 Electrical Installation

## ⚠ WARNING

### Live Electrical Components!

**During installation, testing, servicing and troubleshooting of this product, it may be necessary to work with live electrical components. Have a qualified licensed electrician or other individual who has been properly trained in handling live electrical components perform these tasks. Failure to follow all electrical safety precautions when exposed to live electrical components could result in death or serious injury.**

### Compressor Motor Phase Sequencing

Always verify that proper rotation of the Series R compressor is established before the machine is started. Proper motor rotation requires confirmation of the electrical phase sequence of the power supply. The motor is internally connected for clockwise rotation with incoming power supply phased A, B, C. To confirm the correct phase sequence (ABC), use a Model 45 Associated Research Phase indicator or equivalent.

Basically, voltages generated in each phase of a polyphase alternator or circuit are called phase voltages. In a three-phase circuit, three sine wave voltages are generated, differing in phase by 120 electrical degrees. The order in which the three voltages of a three-phase system succeed one another is called



# Installation Electrical

phase sequence or phase rotation. This is determined by the direction of rotation of the alternator. When rotation is clockwise, phase sequence is usually called "ABC," when counterclockwise, "CBA."

This direction may be reversed outside the alternator by interchanging any two of the line wires. It is this possible interchange of wiring that makes a phase sequence indicator necessary if the operator is to quickly determine the phase rotation of the motor.

## Correcting Improper Electrical Phase Sequence

Proper compressor motor electrical phasing can be quickly determined and corrected before starting the unit. If using an Associated Research Model 45 Phase Sequence Indicator, follow this procedure:

1. Press the STOP button to insure the unit will not attempt to start the compressor.
2. Open the electrical disconnect or circuit protection switch that provides line power to the line power terminal block in the control panel (or to the unit-mounted disconnect).
3. Connect the phase sequence indicator leads to the line power terminal block (or the unit mounted disconnect) as follows:

Phase Seq. Lead	1TB1 Terminal
Black (Phase A)	L1
Red (Phase B)	L2
Yellow (Phase C)	L3

4. Turn power on by closing the unit supply power disconnect switch.
5. Read the phase sequence on the indicator. The "ABC" indicator on the face of the phase indicator will glow if phase is "ABC".

## **⚠ WARNING** **Hazardous Voltage!**

**Disconnect all electric power, including remote disconnects and discharge all motor start/run capacitors before servicing. Follow proper lockout/tagout procedures to ensure the power cannot be inadvertently energized. Verify with an appropriate voltmeter that all capacitors have discharged. Failure to disconnect power and discharge capacitors before servicing could result in death or serious injury.**

6. If the "CBA" indicator glows instead, open the unit main power disconnect and switch two line leads on the line power terminal block (or the unit mounted disconnect). Reclose the main power disconnect and recheck phasing.
7. Reopen the unit disconnect and disconnect the phase indicator.

# Installation Electrical

## Terminal Lugs

Proper starter/control panel line-side lug sizes are specified on the starter submittals. These lug sizes must be compatible with conductor sizes specified by the electrical engineer or contractor. Appropriate lug sizes are provided.

## Circuit Breakers and Non-Fused Disconnect Switches (factory installed Option)

Units that are ordered with factory installed Circuit Breakers or Non-Fused Disconnect Switches ship with the handle in the control panel. The handle must be installed prior to starting the unit.

The operating mechanism is already pre installed on the Disconnect/ Circuit Breaker frame.

The hole locations and shafts lengths have already been cut. And the shaft already installed.

## **⚠ WARNING** **Hazardous Voltage!**

**Disconnect all electric power, including remote disconnects and discharge all motor start/run capacitors before servicing. Follow proper lockout/tagout procedures to ensure the power cannot be inadvertently energized. Verify with an appropriate voltmeter that all capacitors have discharged. Failure to disconnect power and discharge capacitors before servicing could result in death or serious injury.**

1. Attach the handel and gasket to the enclosure door and secure with the four bolts, lock washers and nut as shown in [Figure 19](#). Tighten to 75 in-Lbs.

Note: there is an additional lexan spacer on the handel not shown in the [Figure 19](#), do not remove.

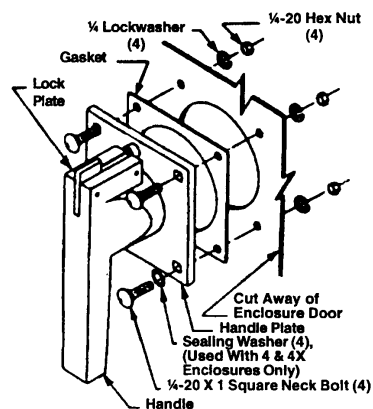

**Figure 19 Handle on Door**

2. Check that when the enclosure door is closed, the handle interlocks with



# Installation Electrical

the shaft in all handle positions except RESET/OPEN. To open the enclosure door when the breaker is in the ON position, rotate the screw slot on the handle plate counter-clockwise. Verify operation.

**Table 14 Lug Sizes**

RLA	Circuit Breaker (copper)	Device Max. Current Rating
0-200	(1) #6 - 350 MCM	250A
200.1-280	(2) 3/0-500 MCM	350A
280.1-320	(2) 3/0 - 500 MCM	400A
320.1-400	(2) 3/0 - 500 MCM	500A
400.1-476	(2) 3/0 - 500 MCM	600A
476.1-560	(4) 250 - 500 MCM	700A
560.1-640	(4) 250 - 500 MCM	800A
640.1-800	(4) 250 - 500 MCM	1000A

RLA	Non-Fused Disconnect Switch	
207, 277, 300	(2) 3/0 - 500 MCM	400A
360, 397	(2) 3/0 - 500 MCM	600A
476	(2) 3/0 - 500 MCM	600A
598	(2) 3/0 - 500 MCM	800A
500	(2) 3/0 - 500 MCM	800A
779	(4) 250 MCM - 500 MCM	1200A

RLA	Main Lugs Only	
1-476	(2) #6-500 MCM	760A
500-598	(2) #4-500 MCM	750A

### Fused Disconnect Switches

Size fused disconnects in accordance with NEC Article 440-22(a).

### Rated Load Amperage (RLA)

The compressor motor RLA for a particular chiller is determined by the field selection program and indicated on the compressor nameplate.

### Minimum Circuit Ampacity (MCA)

The MCA is equal to 1.25 x the compressor RLA (on nameplate).



## Installation Electrical

---

### **Maximum Fuse/Circuit Breaker Size**

The maximum fuse/circuit breaker size is equal to 2.25 x the compressor RLA in accordance with UL 1995, para. 36.15. See also NEC 440-22.

The recommended dual element (RDE) fuse size is equal to 1.75 x RLA in accordance with NEC Table 430-152.

For recommended field connection lug sizes (RTHD starters) see [Table 14](#).



# Installation Electrical

## Application Of Solid-State Starters

The RediStart MX motor starter is a microprocessor-controlled started for induction motors.

### Viewing Parameter Values

Parameter view mode can be entered by:

1. At the default meter display, press the PARAM key to enter parameter mode. "P 1" will be displayed to indicate Parameter 1.
2. Use the UP and DOWN keys to scroll through the available parameters.
3. Pressing the UP key from "P 1" will advance to parameter "P 2".
4. Pressing the DOWN key from "P 1" will wrap around to the highest parameter.
5. The value of the parameter can be viewed by pressing the ENTER key.
6. To view another parameter without changing/saving the parameter, press the PARAM key to return to the parameter number display.

To return to the default meter display either:

1. Press the PARAM key while in the parameter number display mode.
2. Wait 60 seconds and the display will return to the default meter display

### Parameter Settings

Parameter	Description	Setting Range	Units	Default
P1	Motor FLA	1-6400	A <sub>rms</sub>	10
P2	Maximum Motor Current	100-800	%FLA	225
P3	Ramp Time	0-300	Sec	1
P4	Rated RMS Voltage	200, 208, 220, 230, 240, 350, 380, 400, 415, 440, 460, 480, 500, 525, 575, 600	V <sub>rms</sub>	480
P5	CT Ratio (x:1)	72, 96, 144, 288, 864, 1320, 2640, 2880, 3900, 5760	-	288
P6	Software Part Number	Display only	-	-
P7	Passcode	0-9999	-	-
P8	Fault Log	Display faults stored in Fault log	-	-





## Installation Electrical

---

### ⚠ WARNING

#### Electrical Shock!

Contacting any of the motor terminals, even with the motor off can cause a severe, potentially fatal, shock. Follow proper lockout/tagout procedures to ensure the power can not be inadvertently energized. Failure to disconnect power before servicing could result in death or serious injury.

**NOTE: *IMPORTANT! WHEN EVACUATING THE CHILLER'S REFRIGERANT SYSTEM, ALWAYS HAVE THE MAIN POWER DISCONNECT/CIRCUIT BREAKER OPENED.***

***Even when the compressor is not running, voltage is present at the compressor motor terminals, providing the potential for current to flow through a low impedance path.***

***When removing refrigerant for the chiller both the condenser and chilled water pump must be operating to avoid freeze up.***

As the chiller is evacuated below atmospheric pressure, the dielectric strength (resistance to arcing) of the gaseous atmosphere is significantly reduced. Because the SCRs are connected "inside the delta," three of the motor terminals are connected directly to the line voltage. An "arc over" can occur between motor terminals under conditions seen in the evacuation process. If this occurs the circuit breaker (or other external protective devices) will trip in response to high fault currents, and motor damage may also occur. This can be avoided through being certain that the chiller is **fully disconnected from all power sources before beginning pumpdown or evacuation procedures**, as well as guaranteeing that the disconnect cannot be accidentally closed while the chiller is in a vacuum.

# Installation Electrical

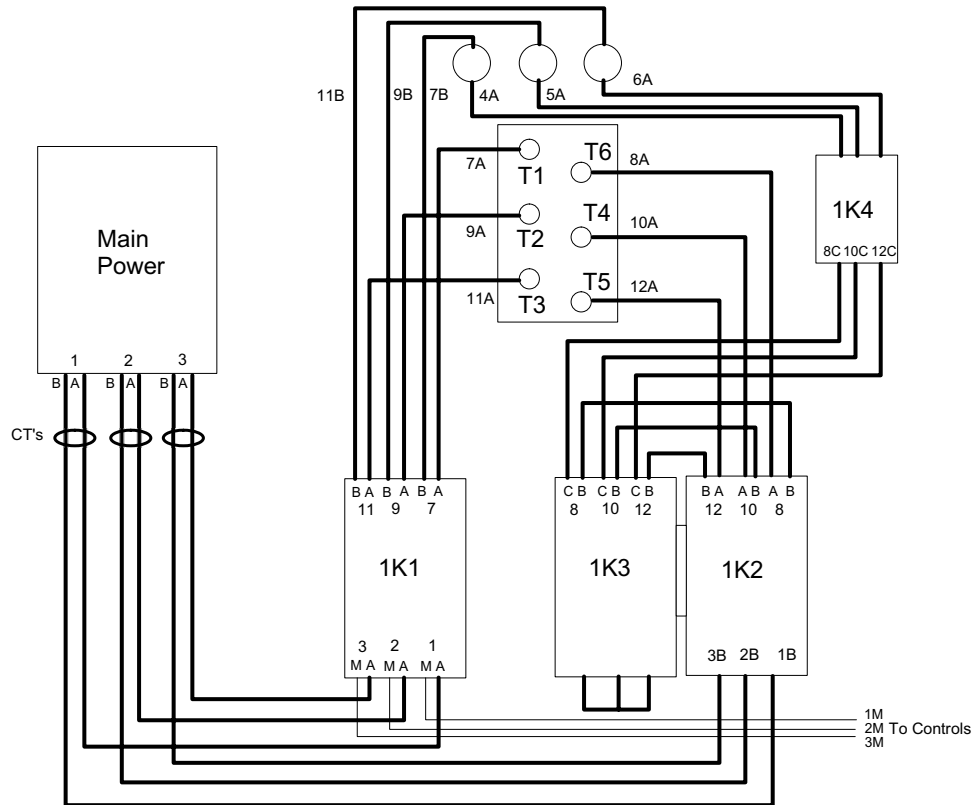

**Figure 20 Y-D Starter Panel Power Wire Routing**

# Installation Electrical

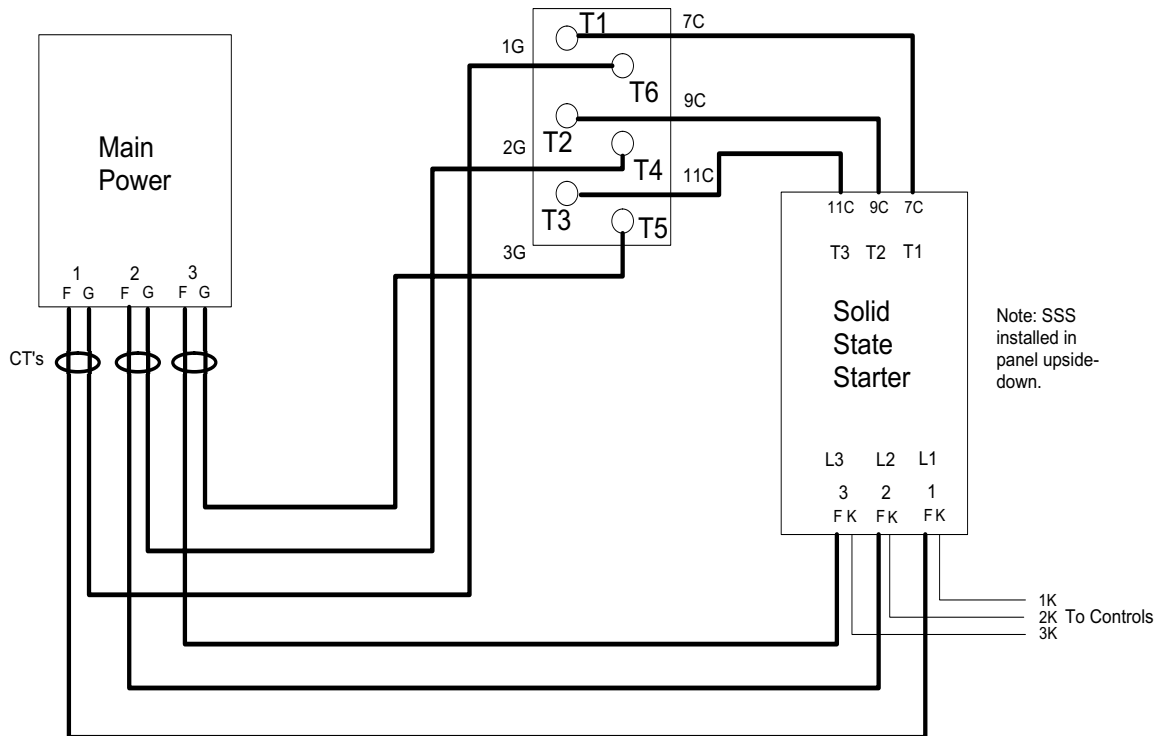

Figure 21 Solid State Starter Panel Power Wire Routing

## Module Connections for Interconnecting Wiring

All connectors can be unplugged or the wires can be removed from the screw assembly. If an entire plug is removed, make sure the plug and the associated jack are marked for proper location identification during reinstallation.

## CAUTION

### Equipment Damage!

**Plugs and jacks must be clearly marked before disconnecting, because specific plugs will fit into other jacks. Possible damage to equipment may occur if the plugs are reversed with the jacks.**

## Interconnecting Wiring (Field Wiring Required)

**NOTE: Important:** Do not turn chiller on or off using the chilled water pump interlocks.



# Installation Electrical

When making field connections, refer to the appropriate field layout, wiring, schematics and controls diagrams that ship with the unit. The diagrams in this manual are typical only and may not match the unit.

Whenever a contact closure (binary output) is referenced, the electrical rating is:

At 120 VAC	7.2 amp resistive
	2.88 amp pilot duty
	1/3 hp, 7.2 FLA, 43.2 LRA
At 240 VAC	5.0 amp resistive
	2.0 amp pilot duty
	1/3 hp, 3.6 FLA, 21.6 LRA

Whenever a dry contact input (binary input) is referenced, the electrical rating is 24VDC, 12 mA.

Whenever a control voltage contact input (binary input) is referenced, the electrical rating is 120 VAC, 5mA.

*NOTE: Asterisked connections require the user to provide an external source of power. The 115V control power transformer is not sized for additional load.*

## Chilled Water Pump Control

CH530 has a evaporator water pump output relay that closes when the chiller is given a signal to go into the Auto mode of operation from any source. The contact is opened to turn off the pump in the event of most machine level diagnostics to prevent the build up of pump heat. To protect against the build-up of pump heat for those diagnostics that do not stop and/or start the pump and to protect against the condition of a bad flow switch, the pump shall always be stopped when the evaporator pressure is seen to be close to the Low Side Evaporator Pressure relief valve setting.

## Chilled Water Flow Interlock

CH530 has an input that will accept a contact closure from a proof-of-flow device such as a flow switch. The flow switch is to be wired in series with the chilled water pump starter's auxiliary contacts. When this input does not prove flow within 20 minutes relative to transition from Stop to Auto modes of the chiller, or if the flow is lost while the chiller is in the Auto mode of operation, the chiller will be inhibited from running by a non-latching diagnostic. The flow switch input shall be filtered to allow for momentary openings and closings of the switch due to turbulent water flow. This is accomplished with a 6 seconds filtering time. The sensing voltage for the condenser water flow switch is 115/240 VAC

**IMPORTANT!** DO NOT cycle the chiller through starting and stopping the chilled water pump. This could cause the compressor to shut down fully loaded. Use the external stop/start input to cycle the chiller.

## Condenser Water Pump Control

CH530 provides a contact closure output to start and stop the condenser water pump. If condenser pumps are arranged in a bank with a common header, the output can be used to control an isolation valve and/or signal another device that an additional pump is required.



## Installation Electrical

---

Condenser Water Pump Prestart time has been added to help with cold condenser water problems. In very cold outdoor ambients, the cooling towers sump cold water would reach the chiller some time after the low system differential pressure protection had run through its ignore time, and result in an immediate shutdown and latching diagnostic. By simply starting the pump earlier, and allowing mixing of the warmer indoor loop with the cooling tower's sump, this problem can be avoided.

### Condenser Water Flow Interlock

The CH530 shall accept an isolated contact closure input from a customer installed proof-of-flow device such as a flow switch and customer provided pump starter auxiliary contact for interlocking with condenser water flow. The input shall be filtered to allow momentary openings and closings of the switch due to turbulent water flow, etc. This shall be accomplished with a 6 seconds filtering time. The sensing voltage for the condenser water flow switch is 115/240 VAC.

On a call for cooling after the restart inhibit timer has timed out, the CH530 shall energize the condenser water pump relay and then check the condenser water flow switch and pump starter interlock input for flow confirmation. Startup of the compressor will not be allowed until flow has proven.

If flow is not initially established within 1200 seconds (20 minutes) of the condenser pump relay energizing, an automatically resetting diagnostic "Condenser Water Flow Overdue" shall be generated which terminates the prestart mode and de-energizes the condenser water pump relay. This diagnostic is automatically reset if flow is established at any later time.

Note: This diagnostic would never automatically reset if CH530 was in control of the condenser pump through its condenser pump relay since it is commanded off at the time of the diagnostic. It could however reset and allow normal chiller operation if the pump was controlled from some external source.

### Chilled Water Reset (CWR)

The MP will reset the chilled water temperature setpoint based on either return water temperature, or outdoor air temperature. The Return Reset option is standard, Outdoor Reset is optional.

The following is selectable:

- RESET TYPE Setpoint.

This can be set to: NO CWR, OUTDOOR AIR TEMPERATURE RESET, RETURN WATER TEMPERATURE RESET, or CONSTANT RETURN WATER TEMPERATURE RESET. The MP shall not permit more than one type of reset to be selected.

- RESET RATIO Setpoints.

For outdoor air temp. reset, both positive and negative reset ratios will be allowed.

- START RESET Setpoints.

- MAXIMUM RESET Setpoints.

The maximum resets shall be with respect to the chilled water setpoint.

When the chiller is running, if any type of CWR is enabled, the MP will step the CWS toward the desired CWS' (based on the below equations and setup parameters) at a rate of 1 degree F every 5 minutes until the Active CWS equals the desired CWS'. When the chiller is not running the CWS will be



## Installation Electrical

---

fully reset immediately (within one minute). The chiller will then start at the Differential to Start value above a fully reset CWS or CWS' for Outdoor, Return, and Constant Return Reset.

### Equations for calculating CWR

Equation used to get Degrees of Reset:

Outdoor Air:

$$\text{Degrees of Reset} = \text{Reset Ratio} * (\text{Start Reset} - \text{TOD})$$

Return Reset:

$$\text{Degrees of Reset} = \text{Reset Ratio} * (\text{Start Reset} - (\text{TWE} - \text{TWL}))$$

Constant Return:

$$\text{Degrees of Reset} = 100\% * (\text{Design Delta Temp} - (\text{TWE} - \text{TWL}))$$

To obtain Active CWS from Degrees of Reset:

$$\text{Active CWS} = \text{Degrees of Reset} + \text{Previous CWS}$$

Note: Previous CWS can either be Front Panel, BAS, or External

Reset Ratio calculation:

The Reset Ratio on the User Interface is displayed as a percentage. To use it in the above equation it must be converted to its decimal form.

$$\text{Reset Ratio percent} / 100 = \text{Reset Ratio decimal}$$

Example of converting Reset Ratio:

If the Reset Ratio displayed on the User Interface is 50% then use  $(50/100) = .5$  in the equation

TOD = Outdoor Air Temp

TWE = Evap Entering Water Temp

TWL = Evap Leaving Water Temp

### Programmable Relays (Alarm and Status) - Optional

CH530 provides a flexible alarm or chiller status indication to a remote location through a hard wired interface to a dry contact closure. Four relays are available for this function, and they are provided (generally with a Quad Relay Output LLID) as part of the Alarm Relay Output Option.

The events/states that can be assigned to the programmable relays are listed in the following table.

# Installation Electrical

**Table 15 Chiller Events/Status Descriptions**

<b>Event/State</b>	<b>Description</b>
Alarm - Latching	This output is true whenever there is any active diagnostic that requires a manual reset to clear, that effects the Chiller, the Circuit, or any of the Compressors on a circuit. This classification does not include informational diagnostics.
Alarm - Auto Reset	This output is true whenever there is any active diagnostic that could automatically clear, that effects the Chiller, the Circuit, or any of the Compressors on a circuit. This classification does not include informational diagnostics. If all of the auto resetting diagnostics were to clear, this output would return to a false condition.
Alarm	This output is true whenever there is any diagnostic effecting any component, whether latching or automatically clearing. This classification does not include informational diagnostics.
Warning	This output is true whenever there is any informational diagnostic effecting any component, whether latching or automatically clearing.
Chiller Limit Mode	This output is true whenever the chiller has been running in one of the Unloading types of limit modes (Condenser, Evaporator, Current Limit or Phase Imbalance Limit) continuously for the last 20 minutes. A given limit or overlapping of different limits must be in effect continuously for 20 minutes prior to the output becoming true. It will become false, if no Unload limits are present for 1 minute. The filter prevents short duration or transient repetitive limits from indicating. The chiller is considered to be in a limit mode for the purposes of front panel display and annunciation, only if it is fully inhibiting loading by virtue of being in either the "hold" or "forced unload" regions of the limit control, excluding the "limited loading region". (In previous designs, the "limit load" region of the limit control was included in the criteria for the limit mode call out on the front panel and annunciation outputs)
Compressor Running	The output is true whenever any compressors are started or running on the chiller and false when no compressors are either starting or running on the chiller. This status may or may not reflect the true status of the compressor in Service Pumpdown if such a mode exists for a particular chiller.
Chiller Head Pressure Relief Request Relay	This relay output is energized anytime the chiller is running in one of the following modes; Ice Making Mode or Condenser Pressure Limit Control Mode continuously for the duration specified by the Chiller Head Relief Relay Filter Time. The Chiller Head Relief Relay Filter Time is a service setpoint. The relay output is de-energized anytime the chiller exits all above modes continuously for the duration specified by the same Chiller Head Relief Relay Filter Time.



# Installation Electrical

The CH530 Service Tool (TechView) is used to install and assign any of the above listed events or status to each of the four relays provided with this option.

The default assignments for the four available relays are listed below.

**Table 16 Programable Relays**

LLID Name	LLID Software Relay Designation	Output Name	Default
Operating Status Programmable Relays	Relay 0	Status Relay 4, J2-1,2,3	Head Pressure Relief Request
	Relay 1	Status Relay 3, J2-4,5,6	Chiller Limit Mode Relay
	Relay 2	Status Relay 2, J2-7,8,9	Chiller Alarm Relay (latching or nonlatching)
	Relay 3	Status Relay 1, J2-10,11,12	Compressor Running Relay

### Emergency Stop

The CH530 provides auxiliary control for a customer specified/installed latching trip out. When this customer-furnished remote contact is provided, the chiller will run normally when the contact is closed. When the contact opens, the unit will trip off on a manually resettable diagnostic. This condition requires manual reset at the chiller switch on the front of the control panel.

### External Auto/Stop

If the unit requires the external Auto/Stop function, the installer must provide leads from the remote contacts to the proper terminals of the LLID on the control panel.

The chiller will run normally when the contacts are closed. When the contact opens, the compressor(s), if operating, will go to the RUN:UNLOAD operating mode and cycle off. Unit operation will be inhibited. Re-closure of the contacts will permit the unit to automatically return to normal operation.

*NOTE: A "panic" stop (similar to "emergency" stop) can be manually commanded by pressing the STOP button twice in a row, the chiller will immediately shut down, but without creating a latching diagnostic.*

### Soft Loading

Soft loading will prevent the chiller from going to full capacity during the pull-down period.

The CH530 control system has two soft loading algorithms running all of the time. They are capacity control soft loading and current limit soft loading. These algorithms introduce the use of a Filtered Chilled Water Setpoint and a Filtered Current Limit Setpoint. After the compressor has been started, the starting point of the filtered chilled water setpoint is initialized to the value of the Evap Leaving Water Temperature. The filtered current limit setpoint is initialized to the value of the Current Limit Softload Starting Percent. These filtered setpoints allow for a stable pull-down that is user adjustable in duration. They also eliminate sudden transients due to setpoint changes during normal chiller operation.

Three settings are used to describe the behavior of soft loading. The setup for softloading can be done using TechView.

- Capacity Control Softload Time: This setting controls the time constant of the Filtered Chilled Water Setpoint. It is settable between 0 and 120 min.





## Installation Electrical

---

- Current Limit Control Softload Time: This Setting controls the time constant of the Filtered Current Limit Setpoint. It is settable between 0 and 120 minutes.
- Current Limit Softload Starting Percent: This setting controls the starting point of the Filtered Current Limit Setpoint. It is adjustable from 40 for RTHD to 100 percent RLA.

### External Base Loading - Optional

Primarily for process control requirements, base loading provides for immediate start and loading of a chiller up to an externally or remotely adjustable current limit setpoint without regard to differential to start or stop, or to leaving water temperature control. This allows the flexibility to prestart or preload a chiller in anticipation of a large load application. It also allows you to keep a chiller on line between processes when leaving water temperature control would normally cycle the unit.

When the base loading option is installed through TechView, it will be controllable through DynaView/TechView, External Hardware Interface or Tracer (if Tracer is installed). Order for precedence for all setpoints, DynaView/TechView then External then Tracer from lowest to highest priority. If one of the higher priority setpoints drops out due to a bad sensor or communication loss then base loading shall go to the next lowest priority of command and setpoint. The command settings and control setpoints associated with base loading are explained below.

### Base Loading Control setpoint

This setpoint has three possible sources, an External Analog Input, DynaView/TechView or Tracer.

- DynaView/TechView Base Loading Control Setpoint  
The range is 40 - 100 % Compressor Load (Max %RLA). The default is 50%.
- Tracer Base Loading Control Setpoint  
The range is 40 - 100 % Compressor Load (Max %RLA). The default is 50%.
- External Base Loading Setpoint  
This is an Analog Input that sets the base loading setpoint. This signal can be controlled by either a 2-10Vdc or 4-20ma Signal based on configuration information. The equations show the relationship between input and percent compressor load:  
If the input is configured as a 4 - 20 mA:  
$$\% \text{ Load} = 3.75 * (\text{mA Input}) + 25$$
  
If the input is configured as a 2 - 10 Vdc:  
$$\% \text{ Load} = 7.5 * (\text{Vdc Input}) + 25$$

### Summit Interface - Optional

CH530 provides an optional interface between the chiller and a Trane Summit BAS. A Communications interface LLID shall be used to provide "gateway" functionality between the Chiller and Summit.



## Installation Electrical

---

### **LonTalk Communication Interface - Optional**

CH530 provides an optional LonTalk Communication Interface (LCI-C) between the chiller and a Building Automation System (BAS). An LCI-C LLID shall be used to provide "gateway" functionality between the LonTalk protocol and the Chiller.

### **Ice Making Contact - Optional**

CH530 accepts a contact closure input to initiate Ice Building. When in the ice building mode, the compressor will be fully loaded (not given a low setpoint) and will continue to operate until the ice contacts open or the return water temperature reaches the Ice Termination Setpoint. If terminated on return setpoint, CH530 will not allow the chiller to restart until the ice making contact is opened.

### **Ice Machine Control - Optional**

CH530 provides an output contact closure that can be used as a signal to the system that ice building is in operation. This relay will be closed when ice building is in progress and open when ice building has been terminated by either CH530 or the remote interlock. It is used to signal the system changes required to convert to and from ice making.

### **External Chilled Water Setpoint - Optional**

CH530 will accept either a 2-10 VDC or a 4-20 mA input (J9-4, J9-5) signal, to adjust the chilled water setpoint from a remote location.

### **External Current Limit Setpoint - Optional**

CH530 will accept either a 2-10VDC or a 4-20mA input (J7-11, J7-12) signal to adjust the current limit setpoint from a remote location.

### **Percent Condenser Pressure Output - Optional**

CH530 provides a 2-10 VDC analog output to indicate percent High Pressure Cutout (HPC) condenser pressure.

Percent HPC = (Condenser Pressure/High Pressure Cutout Setpoint)\*100

### **Compressor Percent RLA Output - Optional**

CH530 provides a 2-10 Vdc analog output to indicate % RLA of compressor starter average phase current. 2 to 10 Vdc corresponds to 0 to 120% RLA.



## Operating Principles Mechanical

---

This section contains an overview of the operation and maintenance of Series R chillers equipped with microcomputer-based control systems. It describes the overall operating principles of the RTHD water chiller..

Following the section is information regarding specific operating instructions, detailed descriptions of the unit controls and options (Operator Interface - Control Systems), and maintenance procedures that must be performed regularly to keep the unit in top condition (Periodic Maintenance and Maintenance Procedures). Diagnostic information (Diagnostics) is provided to allow the operator to identify system malfunctions.

*NOTE: To ensure proper diagnosis and repair, contact a qualified service organization if a problem should occur.*

### General

The Model RTHD units are single-compressor water-cooled liquid chillers. These units are equipped with unit-mounted starter/control panels.

The basic components of an RTHD unit are:

- Unit-mounted panel containing starter and TracerCH530 controller and Input/Output LLIDS
- Helical-rotary compressor
- Evaporator
- Electronic expansion valve
- Water-cooled condenser with integral subcooler
- Oil supply system
- Oil cooler (application dependent)
- Related interconnecting piping.

### Refrigeration (Cooling) Cycle

The refrigeration cycle of the Series R chiller is conceptually similar to that of other Trane chiller products. It makes use of a shell-and-tube evaporator design with refrigerant evaporating on the shell side and water flowing inside tubes having enhanced surfaces.

The compressor is a twin-rotor helical rotary type. It uses a suction gas-cooled motor that operates at lower motor temperatures under continuous full and part load operating conditions. An oil management system provides an almost oil-free refrigerant to the shells to maximize heat transfer performance, while providing lubrication and rotor sealing to the compressor. The lubrication system ensures long compressor life and contributes to quiet operation.

Condensing is accomplished in a shell-and-tube heat exchanger where refrigerant is condensed on the shell side and water flows internally in the tubes.

Refrigerant is metered through the flow system using an electronic expansion valve, that maximizes chiller efficiency at part load.

A unit-mounted starter and control panel is provided on every chiller. Micro-processor-based unit control modules (Tracer CH530) provide for accurate chilled water control as well as monitoring, protection and adaptive limit functions. The "adaptive" nature of the controls intelligently prevents the chiller from operating outside of its limits, or compensates for unusual operating conditions, while keeping the chiller running rather than simply tripping due to a safety concern. When problems do occur, diagnostic messages assist the operator in troubleshooting.

## Operating Principles Mechanical

### Cycle Description

The refrigeration cycle for the RTHD chiller can be described using the pressure-enthalpy diagram shown in Figure 22. Key State Points are indicated on the figure and are referenced in the discussion following. A schematic of the system showing the refrigerant flow loop as well as the lubricant flow loop is shown in Figure 25.

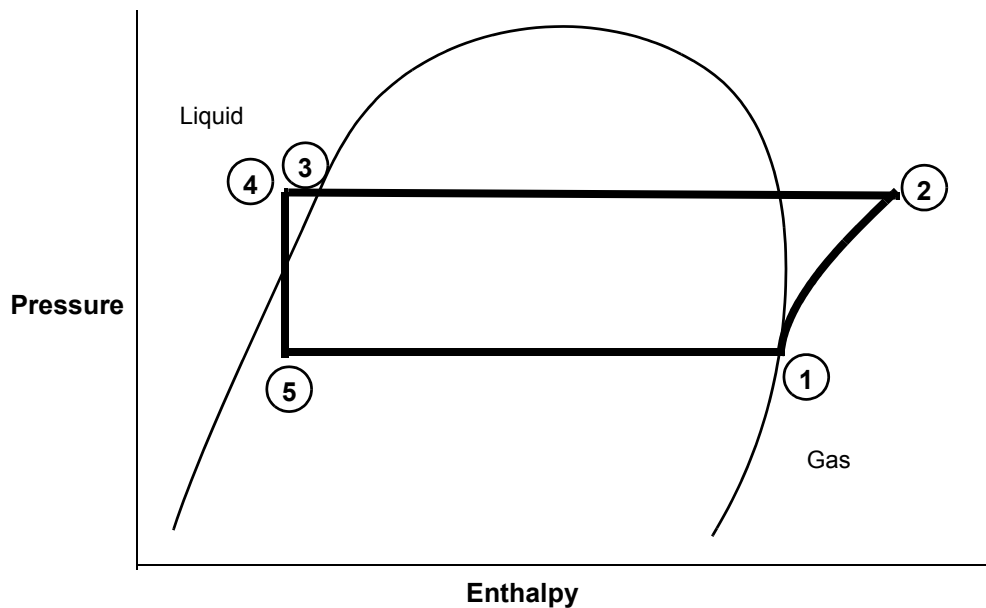

**Figure 22 Pressure /Enthalpy Curve**

Evaporation of refrigerant occurs in the evaporator. A metered amount of refrigerant liquid enters a distribution system in the evaporator shell and is then distributed to the tubes in the evaporator tube bundle. The refrigerant vaporizes as it cools the water flowing through the evaporator tubes. Refrigerant vapor leaves the evaporator as saturated vapor (State Pt. 1).

The refrigerant vapor generated in the evaporator flows to the suction end of the compressor where it enters the motor compartment of the suction-gas-cooled motor. The refrigerant flows across the motor, providing the necessary cooling, then enters the compression chamber. Refrigerant is compressed in the compressor to discharge pressure conditions. Simultaneously, lubricant is injected into the compressor for two purposes: (1) to lubricate the rolling element bearings, and (2) to seal the very small clearances between the compressor's twin rotors. Immediately following the compression process the lubricant and refrigerant are effectively divided using an oil separator. The oil-free refrigerant vapor enters the condenser at State Pt. 2. The lubrication and oil management issues are discussed in more detail in the compressor description and oil management sections that follow.

Baffles within the condenser shell distribute the compressed refrigerant vapor evenly across the condenser tube bundle. Cooling tower water, circulating through the condenser tubes, absorbs heat from this refrigerant and condenses it.

## Operating Principles Mechanical

As the refrigerant leaves the bottom of the condenser (State Pt. 3), it enters an integral subcooler where it is subcooled before traveling to the electronic expansion valve (State Pt. 4). The pressure drop created by the expansion process vaporizes a portion of the liquid refrigerant. The resulting mixture of liquid and gaseous refrigerant then enters the Evaporator Distribution system (State Pt. 5). The flash gas from the expansion process is internally routed to compressor suction, and while the liquid refrigerant is distributed over the tube bundle in the evaporator.

The RTHD chiller maximizes the evaporator heat transfer performance while minimizing refrigerant charge requirements. This is accomplished by metering the liquid refrigerant flow to the evaporator's distribution system using the electronic expansion valve. A relatively low liquid level is maintained in the evaporator shell, which contains a bit of surplus refrigerant liquid and accumulated lubricant. A liquid level measurement device monitors this level and provides feedback information to the CH530 unit controller, which commands the electronic expansion valve to reposition when necessary. If the level rises, the expansion valve is closed slightly, and if the level is dropping, the valve is opened slightly such that a steady level is maintained.

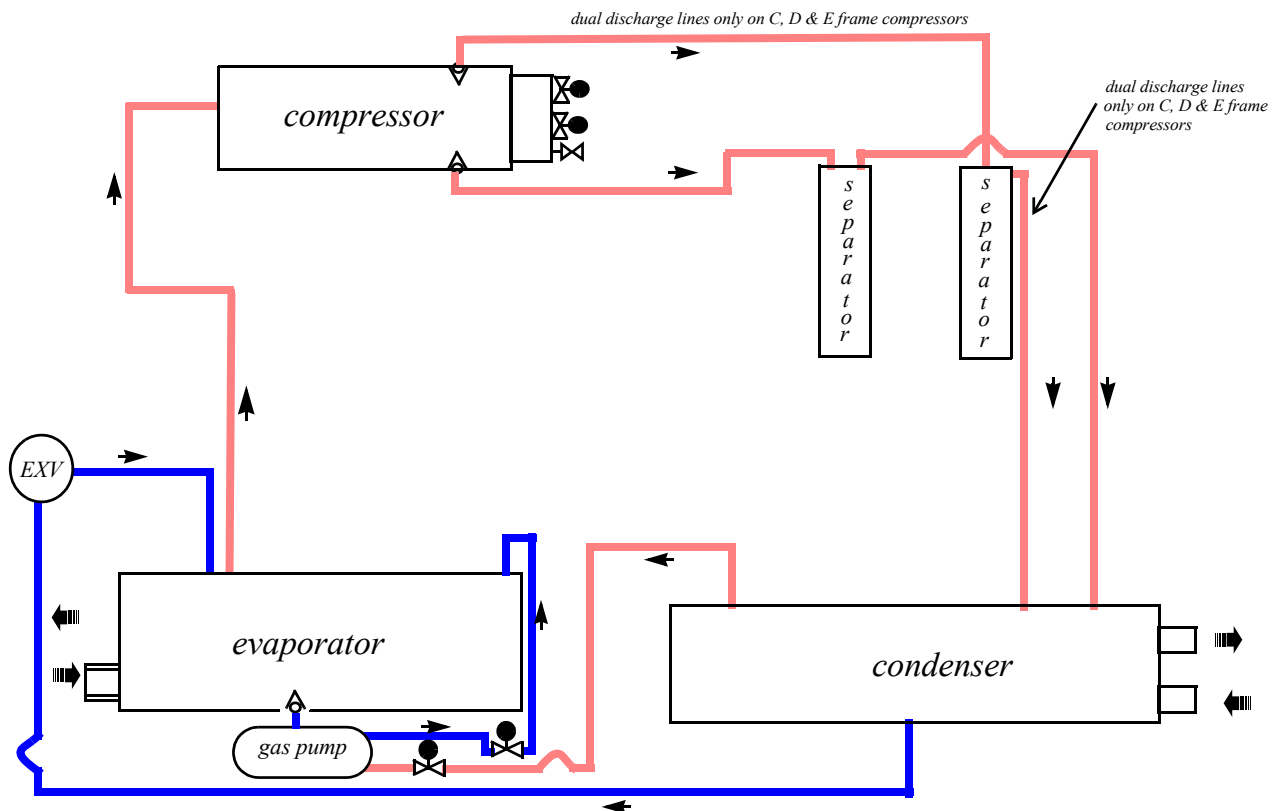

Figure 23 Refrigerant Flow Diagram

# Operating Principles Mechanical

## Compressor Description

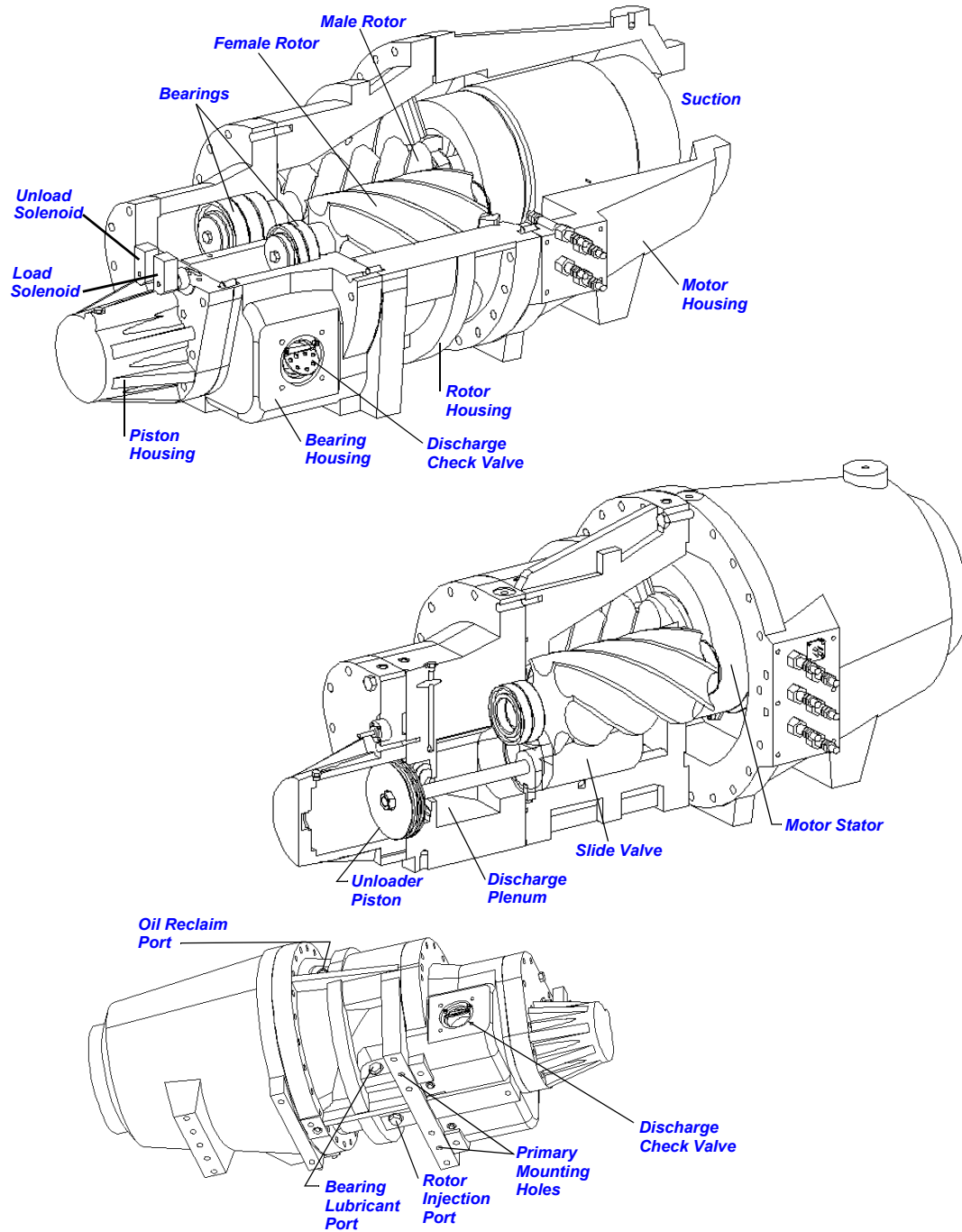

Figure 24 Compressor Description

## Operating Principles Mechanical

---

The compressor used by the Series R chiller consists of three distinct sections: the motor, the rotors and the bearing housing. Refer to [Figure 24](#).

### Compressor Motor

A two-pole, hermetic, squirrel-cage induction motor directly drives the compressor rotors. The motor is cooled by suction vapor drawn from the evaporator and entering the end of the motor housing ([Figure 24](#)).

### Compressor Rotors

Each Series R chiller uses a semi-hermetic, direct-drive helical rotary type compressor. Excluding the bearings, each compressor has only 3 moving parts: 2 rotors - "male" and "female" - provide compression, and a slide valve that controls capacity. See [Figure 24](#). The male rotor is attached to, and driven by the motor, and the female rotor is, in turn, driven by the male rotor. Separately housed bearing sets are provided at each end of both rotors on the RTHD units. The slide valve is located below (and moves along) the rotors.

The helical rotary compressor is a positive displacement device. Refrigerant from the evaporator is drawn into the suction opening at the end of the motor section. The gas is drawn across the motor, cooling it, and then into the rotor section. It is then compressed and released directly into the discharge plenum.

There is no physical contact between the rotors and compressor housing. Oil is injected into the bottom of the compressor rotor section, coating both rotors and the compressor housing interior. Although this oil does provide rotor lubrication, its primary purpose is to seal the clearance spaces between the rotors and compressor housing. A positive seal between these internal parts enhances compressor efficiency by limiting leakage between the high pressure and low pressure cavities.

Capacity control is accomplished by means of a slide valve assembly located in the rotor/bearing housing sections of the compressor. Positioned along the bottom of the rotors, the slide valve is driven by a piston/cylinder along an axis that parallels those of the rotors ([Figure 24](#)).

Compressor load condition is dictated by the coverage of the rotors by the slide valve. When the slide valve fully covers the rotors, the compressor is fully loaded. Unloading occurs as the slide valve moves away from the suction end of the rotors. Slide valve unloading lowers refrigeration capacity by reducing the compression surface of the rotors.

### Slide Valve Movement

Movement of the slide valve piston ([Figure 24](#)) determines slide valve position which, in turn, regulates compressor capacity. Compressed vapor flowing in to and out of the cylinder governs piston movement, and is controlled by the load and unload solenoid valves.

The solenoid valves (both normally closed) receive "load" and "unload" signals from the CH530, based on system cooling requirements. To load the compressor, the CH530 opens the load solenoid valve. The pressurized vapor flow then enters the cylinder and, with the help of the lower suction pressure acting on the face of the unloader valve, moves the slide valve over the rotors toward the suction end of the compressor.

The compressor is unloaded when the unload solenoid valve is open. Vapor "trapped" within the cylinder is drawn out into the lower-pressure suction area of the compressor. As the pressurized vapor leaves the cylinder, the slide valve slowly moves away from the rotors toward the discharge end of the rotors.



## Operating Principles Mechanical

---

When both solenoid valves are closed, the present level of compressor loading is maintained.

On compressor shutdown, the unload solenoid valve is energized. Springs assist in moving the slide valve to the fully-unloaded position, so the unit always starts fully unloaded.

### Oil Management System

#### Oil Separator

The oil separator consists of a vertical cylinder surrounding an exit passageway. Once oil is injected into the compressor rotors, it mixes with compressed refrigerant vapor and is discharged directly into the oil separator. As the refrigerant-and-oil mixture is discharged into the oil separator, the oil is forced outward by centrifugal force, collects on the walls of the cylinder and drains to the bottom of the oil separator cylinder. The accumulated oil then drains out of the cylinder and collects in the oil sump located near the top and in-between the evaporator and condenser shells.



# Operating Principles Mechanical

Oil that collects in the oil tank sump is at condensing pressure during compressor operation; therefore, oil is constantly moving to lower pressure areas.

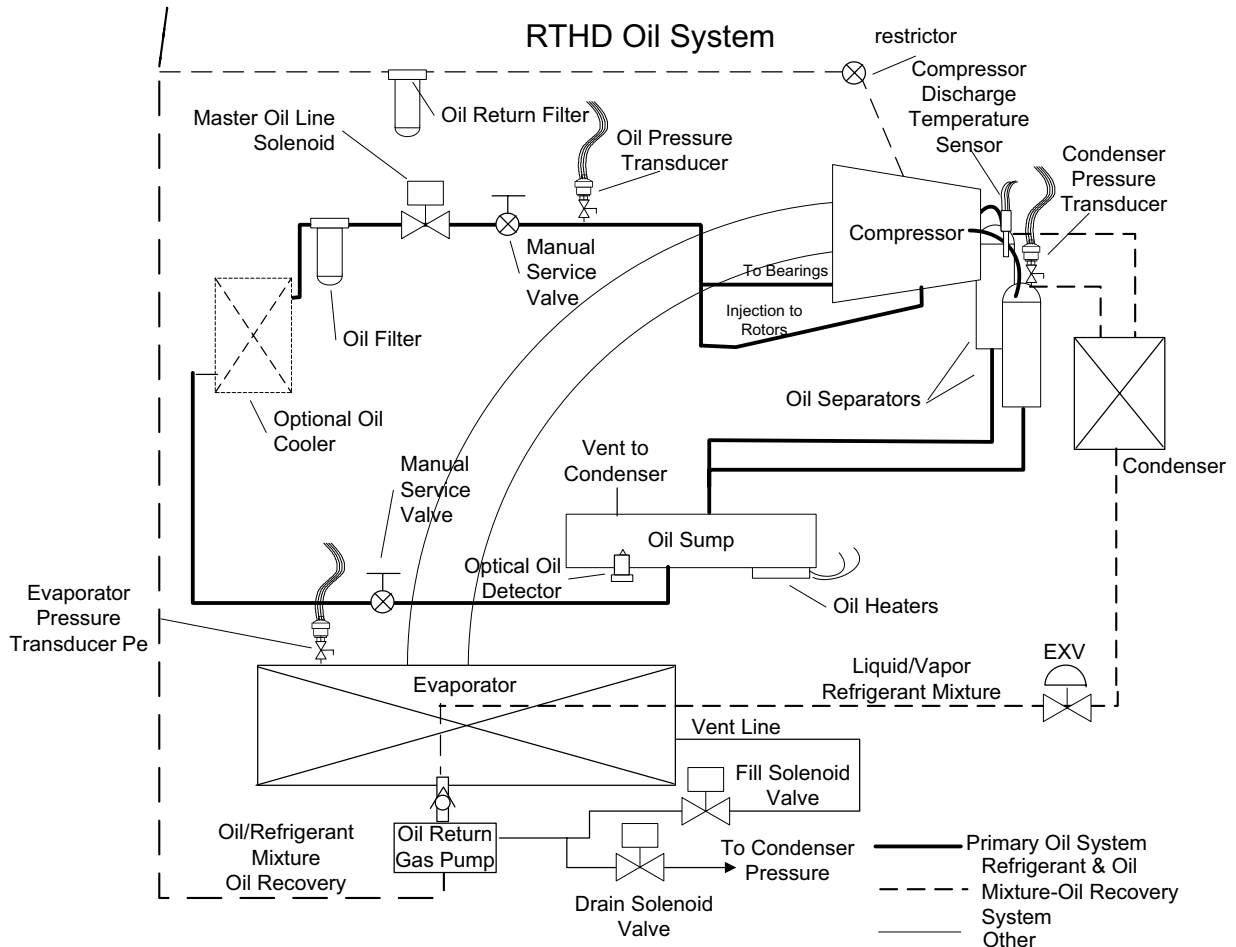

Figure 25 Oil Flow Diagram

## Oil Flow Protection

Oil flowing through the lubrication circuit flows from the oil sump to the compressor (see Figure 25). As the oil leaves the sump, it passes through a service valve, an oil cooler (if used), oil filter, master solenoid valve, and another service valve. Oil flow then splits into two distinct paths, each performing a separate function: (1) bearing lubrication and cooling, and (2) compressor oil injection.

Oil flow and quality is proven through a combination of a number of sensors, most notably a pressure transducer and the optical oil level sensor.



## Operating Principles Mechanical

---

If for any reason oil flow is obstructed because of a plugged oil filter, closed service valve, faulty master solenoid, or other source, the oil pressure transducer will read an excessively high pressure drop in the oil system (relative to the total system pressure) and shut down the chiller.

Likewise, the optical oil level sensor can detect the lack of oil in the primary oil system (which could result from improper oil charging after servicing, or oil logging in other parts of the system). The sensor will prevent the compressor from starting or running unless an adequate volume of oil is present. The combination of these two devices, as well as diagnostics associated with extended low system differential pressure and low superheat conditions, can protect the compressor from damage due to severe conditions, component failures, or improper operation.

If the compressor stops for any reason, the master solenoid valve closes; this isolates the oil charge in the sump during "off" periods. With the oil efficiently contained in the sump, oil is immediately available to the compressor at start-up. Such flows would otherwise purge oil from the lines and the oil sump, which is an undesirable effect.

To ensure the required system differential pressure is adequate to move oil to the compressor, the CH530 attempts to both control a minimum system differential pressure as well as monitor it. Based on readings from pressure transducers in both the evaporator and condenser, the EXV is modulated to maintain evaporator pressure at a minimum of 25 psid below the condenser pressure. Once the minimum is met, the EXV will return to normal liquid level control (see the paragraph on "Cycle Description"). If the differential is significantly lower than required, the unit will trip and initiate an appropriate diagnostics and would enforce a compressor "cool down" period.

To ensure proper lubrication and minimize refrigerant condensation in the oil sump, heaters are mounted on the bottom of the oil sump. An auxiliary contact of the compressor starter, energizes these heaters during the compressor off cycle to maintain a proper elevation of the oil temperature. The heater element is continuously energized while the compressor is off and does not cycle on temperature.

### **Oil Filter**

All Series R chillers are equipped with replaceable-element oil filters. Each removes any impurities that could foul the compressor internal oil supply galleries. This also prevents excessive wear of compressor rotor and bearing surfaces and promotes long bearing life. Refer to the Section 9 for recommended filter element replacement intervals.

### **Compressor Bearing Oil Supply**

Oil is injected into the rotor housing where it is routed to the bearing groups located in the motor and bearing housing sections. Each bearing housing is vented to compressor suction so oil leaving the bearings returns through the compressor rotors to the oil separator.

### **Compressor Rotor Oil Supply**

Oil flowing through this circuit enters the bottom of the compressor rotor housing. From there it is injected along the rotors to seal clearance spaces around the rotors and lubricate the contact line between the male and female rotors.



## Operating Principles Mechanical

---

### Lubricant Recovery

Despite the high efficiency of the oil separators, a small percentage of oil will get past them, move through the condenser, and eventually end up in the evaporator. This oil must be recovered and returned to the oil sump. The function of active oil return is accomplished by a pressure-actuated pump referred to as the "gas pump."

The gas pump, mounted just beneath the evaporator, is a cylinder with four ports controlled by two solenoids. The pump serves to return accumulating oil in the evaporator to the compressor at regular time intervals. As the refrigerant-oil mixture enters the gas pump from the bottom of the evaporator, a fill solenoid opens to allow refrigerant vapor to be vented into the top of the evaporator, and is then closed. A second solenoid then opens to allow refrigerant at condenser pressure to enter the gas pump. Simultaneously, a check valve prevents reverse flow back into the evaporator. A liquid refrigerant and oil mixture is displaced from the gas pump cylinder and is directed through a filter to the compressor. The oil then combines with oil injected into the compressor and returns to the oil sump via the oil separators.

### Oil Cooler

The oil cooler is a brazed plate heat exchanger located near the oil filter. It is designed to transfer approximately one ton of heat from the oil to the suction side of the system. Subcooled liquid is the cooling source.

The oil cooler is required on units running at high condensing or low suction temperatures. The high discharge temperatures in these applications increase oil temperatures above the recommended limits for adequate lubrication and reduce the viscosity of the oil.



# **Operating Principles Mechanical**

---

# Operator Interface Controls

---

## CH530 Communications Overview

The Trane CH530 control system that runs the chiller consists of several elements:

- The main processor collects data, status, and diagnostic information and communicates commands to the starter module and the LLID (for Low Level Intelligent Device) bus. The main processor has an integral display (DynaView).
- Higher level modules (e.g. starter) exist only as necessary to support system level control and communications. The starter module provides control of the starter when starting, running, and stopping the chiller motor. It also processes its own diagnostics and provides motor and compressor protection.
- Low level intelligent device (LLID) bus. The main processor communicates to each input and output device (e.g. temperature and pressure sensors, low voltage binary inputs, analog input/output) all connected to a four-wire bus, rather than the conventional control architecture of signal wires for each device.
- The communication interface to a building automation system (BAS).
- A service tool to provide all service/maintenance capabilities.

Main processor and service tool (TechView) software is downloadable from [www.Trane.com](http://www.Trane.com). The process is discussed later in this section under TechView Interface.

DynaView provides bus management. It has the task of restarting the link, or filling in for what it sees as “missing” devices when normal communications has been degraded. Use of TechView may be required.

The CH530 uses the IPC3 protocol based on RS485 signal technology and communicating at 19.2 Kbaud to allow 3 rounds of data per second on a 64-device network. A typical four-compressor RTAC will have around 50 devices.

Most diagnostics are handled by the DynaView. If a temperature or pressure is reported out of range by a LLID, the DynaView processes this information and calls out the diagnostic. The individual LLIDs are not responsible for any diagnostic functions. The only exception to this is the Starter module.

*NOTE: It is imperative that the CH530 Service Tool (TechView) be used to facilitate the replacement of any LLID or reconfigure any chiller component. TechView is discussed later in this section.*

## Controls Interface

### DynaView

Each chiller is equipped with the DynaView interface. DynaView has the capability to display additional information to the advanced operator including the ability to adjust settings. Multiple screens are available and text is presented in multiple languages as factory-ordered or can be easily downloaded online.

### TechView

TechView can be connected to the DynaView module and provides further data, adjustment capabilities, diagnostics information, downloadable software, and downloadable languages.

# Operator Interface Controls

## DynaView Interface

The display on DynaView is a 1/4 VGA display with a resistive touch screen and an LED backlight. The display area is approximately 4 inches wide by 3 inches high (102mm x 60mm).

Figure 26 DynaView



### Key Functions

In this touch screen application, key functions are determined completely by software and change depending upon the subject matter currently being displayed. The basic touch screen functions are outlined below.

## CAUTION

### Equipment Damage!

**Putting excessive pressure on the touch screen could cause damage. It takes less than 15 lbs of force to break the screen.**

### Radio Buttons

Radio buttons show one menu choice among two or more alternatives, all visible. (the AUTO button in [Figure 26](#).) The radio button model mimics the buttons used on old-fashioned radios to select stations. When one is pressed, the one that was previously pressed “pops out” and the new station is selected. In the DynaView, model the possible selections are each associated with a button. The selected button is darkened, presented in reverse video to indicate it is the selected choice. The full range of possible choices as well as the current choice is always in view.

### Spin Value Buttons

Spin values are used to allow a variable setpoint to be changed, such as leaving water setpoint. The value increases or decreases by touching the increment (+) or decrement (-) arrows.

# Operator Interface Controls

## Action Buttons

Action buttons appear temporarily and provide the user with a choice such as **Enter** or **Cancel**.

## File Folder Tabs

File folder tabs are used to select a screen of data. Just like tabs in a file folder, these serve to title the folder/screen selected, as well as provide navigation to other screens. In DynaView, the tabs are in one row across the top of the display. The folder tabs are separated from the rest of the display by a horizontal line. Vertical lines separate the tabs from each other. The folder that is selected has no horizontal line under its tab, thereby making it look like a part of the current folder (as would an open folder in a file cabinet). The user selects a screen of information by touching the appropriate tab.

## Display Screens

### Basic Screen Format

The basic screen format appears as:

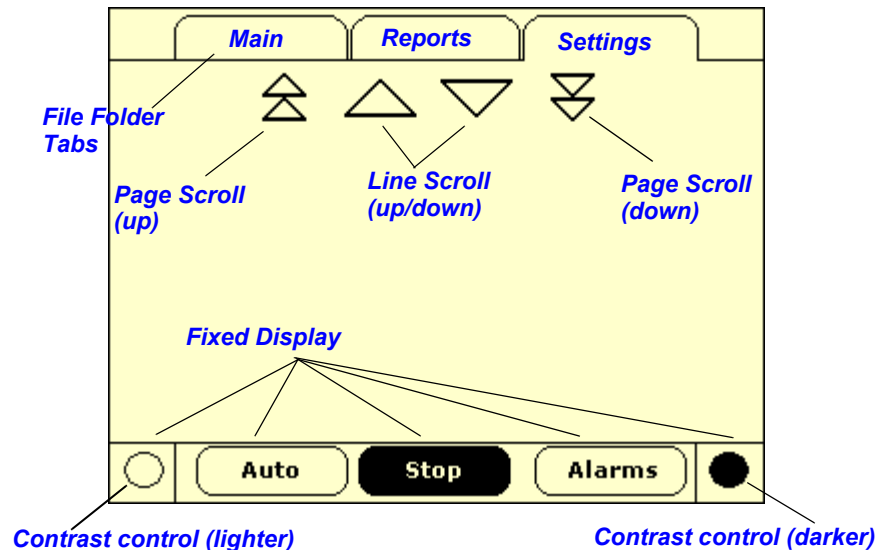

The file folder tabs across the top of the screen are used to select the various display screens.

The main body of the screen is used for description text, data, setpoints, or keys (touch sensitive areas). The Chiller Mode is displayed here.

The double up arrows cause a page-by-page scroll either up or down. The single arrow causes a line by line scroll to occur. At the end of the page, the appropriate scroll bar will disappear.

A double arrow pointing to the right indicates more information is available about the specific item on that same line. Pressing it will bring you to a sub-screen that will present the information or allow changes to settings.

The bottom of the screen (Fixed Display) is present in all screens and contains the following functions. The **left circular area** is used to reduce the contrast/viewing angle of the display. The **right circular area** is used to increase the contrast/viewing angle of the display. The contrast may require re-adjustment at ambient temperatures significantly different from those present at last adjustment.

## Operator Interface Controls

---

The other functions are critical to machine operation. The AUTO and STOP keys are used to enable or disable the chiller. The key selected is in black (reverse video). The chiller will stop when the STOP key is touched and after completing the Run Unload mode.

Touching the AUTO key will enable the chiller for active cooling if no diagnostic is present. (A separate action must be taken to clear active diagnostics.)

The AUTO and STOP keys, take precedence over the Enter and Cancel keys. (While a setting is being changed, AUTO and STOP keys are recognized even if Enter or Cancel has not been pressed.)

The ALARMS button appears only when an alarm is present, and blinks (by alternating between normal and reverse video) to draw attention to a diagnostic condition. Pressing the ALARMS button takes you to the corresponding tab for additional information.

### Keypad/Display Lockout Feature

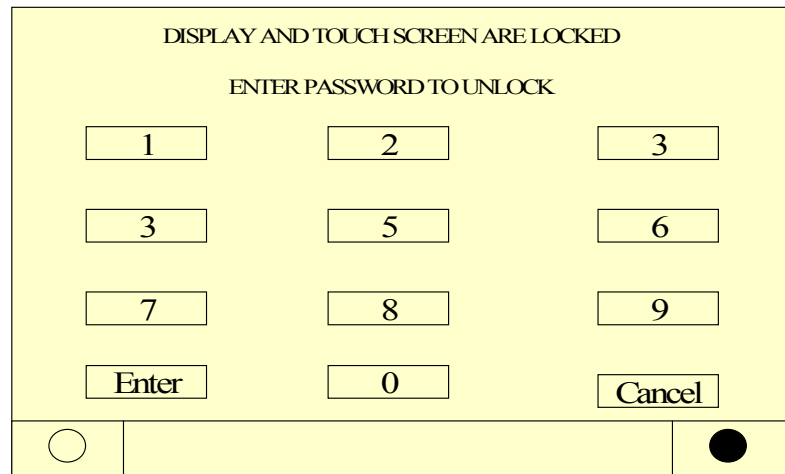

*NOTE: The DynaView display and Touch Screen Lock screen is shown below. This screen is used if the Display and touch screen and lock feature is enabled. Thirty minutes after the last keystroke, this screen is displayed and the Display and Touch Screen is locked out until the sequence "159 <ENTER>" is pressed.*

Until the proper password is entered, there will be no access to the DynaView screens including all reports, setpoints, and Auto/Stop/Alarms/Interlocks.

The password "159" can not be changed from either DynaView or TechView.



# Operator Interface Controls

## Main Screen

The Main screen is a summary of the chiller's activity. The Main screen is the default screen. After an idle time of 30 minutes the CH530 will display the Main screen with the first data fields.

The remaining items (listed in the following table) are viewed by selecting the up/down arrow icons.

Figure 27. Main Screen

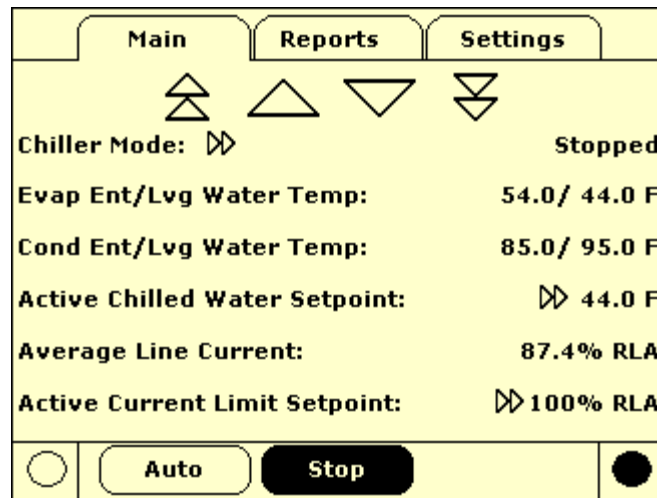

Table 17 Main Screen Items

Description	Resolution	Units
Chiller Mode (>> submodes)		Text
Evap Ent/Lvg Water Temp	X.X	F / C
Cond Ent/Lvg Water Temp	X.X	F / C
Active Chilled Water Setpoint (>>source)	X.X	F / C
Average Line Current	X	% RLA
Active Current Limit Setpoint (>>source)	X	% RLA
Active Base Loading Setpoint (>>source)	X	%
Active Ice Termination Setpoint (>>source)	X.X	F / C
Outdoor Air Temperature	X.X	F / C
Software Type	RTH	Text
Software Version	X.XX	Text



# Operator Interface Controls

## Chiller Operating Modes

The machine-operating mode indicates the operational status of the chiller. A sub-screen with additional mode summary information is provided by selection of an additional information icon (>>). The operating mode line will remain stationary while the remaining status items scroll with the up/down arrow keys. The following is a list of all Top Level and Sub-modes.

**Table 18 Operating Modes**

<b>Chiller Modes</b>	<b>Description</b>
MP Resetting <sup>1</sup>	
Stopped <sup>1</sup>	The chiller is not running and cannot run without intervention. Further information is provided by the sub-mode:
Local Stop <sup>2</sup>	Chiller is stopped by DynaView Stop button command- cannot be remotely overridden.
Panic Stop <sup>2</sup>	Chiller is stopped by the DynaView Panic Stop (by pressing Stop button twice in succession) - previous shutdown was manually commanded to shutdown immediately without a run-unload or pumpdown cycle - cannot be remotely overridden.
Diagnostic Shutdown - Manual Reset <sup>2</sup>	The chiller is stopped by a diagnostic that requires manual intervention to reset.
Other sub-modes are possible in conjunction with at least one of the above modes - See items below for their descriptions:	
Diagnostic Shutdown - Auto Reset <sup>2</sup>	
Start Inhibited by External Source <sup>2</sup>	
Start Inhibited by BAS <sup>2</sup>	
Waiting for BAS Communications <sup>2</sup>	
Ice Building to Normal Transition <sup>2</sup>	
Ice Building is Complete <sup>2</sup>	
Waiting for Oil Level <sup>2</sup>	
Run Inhibit <sup>1</sup>	The chiller is currently being inhibited from starting (and running*), but may be allowed to start if the inhibiting or diagnostic condition is cleared. Further information is provided by the sub-mode:
Diagnostic Shutdown - Auto Reset <sup>2</sup>	The entire chiller is stopped by a diagnostic that may automatically clear.
Start Inhibited by External Source <sup>2</sup>	The chiller is inhibited from starting (and running) by the "external stop" hardwired input.
Start Inhibited by BAS <sup>2</sup>	The chiller is inhibited from starting (and running) by command from a Building Automation System via the digital communication link (com 4 or com 5).

1 - Top Level Mode  
2 - Sub Level Mode

# Operator Interface Controls

**Table 18 Operating Modes**

<b>Chiller Modes</b>	<b>Description</b>
Waiting for BAS Communications <sup>2</sup>	This is a transient mode - 15-min. max, and is only possible if the chiller is in the Auto - Remote command mode. After a power up reset, it is necessary to wait for valid communication from a Building Automation System (Tracer) to know whether to run or stay inhibited. Either valid communication will be received from the Building Automation System (e.g. Tracer), or a communication diagnostic ultimately will result. In the latter case the chiller will revert to Local control.
Power Up Delay Inhibit <sup>2</sup> min:sec	The compressor is currently being inhibited from starting as part of the power up start delay (or staggered start) feature. This feature is intended to prevent multiple chillers from all starting simultaneously if power is restored to all chillers simultaneously.
Ice Building to Normal Transition <sup>2</sup>	The chiller is inhibited from running for a brief period of time if it is commanded from active ice building mode into normal cooling mode via the ice building hardwired input or Tracer. This allows time for the external system load to "switchover" from an ice bank to the chilled water loop, and provides for a controlled pull down of the loop's warmer temperature. This mode is not seen if the ice making is automatically terminated on return brine temperature per the mode below.
Ice Building is Complete <sup>2</sup>	The chiller is inhibited from running as the Ice Building process has been normally terminated on the return brine temperature. The chiller will not start unless the ice building command (hardwired input or Building Automation System command) is removed or cycled.(contact opened)
Low Diff Rfght Pres Cool-Down Time <sup>2</sup> mn:sec	See oil flow protection spec
Auto <sup>1</sup>	The chiller is not currently running but can be expected to start at any moment given that the proper conditions and interlocks are satisfied. Further information is provided by the sub-mode:
Waiting For Evap Water Flow <sup>2</sup>	The chiller will wait up to 4 minutes in this mode for evaporator water flow to be established per the flow switch hardwired input.
Waiting for Need to Cool <sup>2</sup>	The chiller will wait indefinitely in this mode, for an evaporator leaving water temperature higher than the Chilled Water Setpoint plus the Differential to Start.
Waiting to Start <sup>1</sup>	The chiller is not currently running and there is a call for cooling but start is delayed by certain interlocks or proofs. Further information is provided by the sub-mode:
Waiting For Cond Water Flow <sup>2</sup>	The chiller will wait up to 4 minutes in this mode for condenser water flow to be established per the flow switch hardwired input.
Waiting for Oil Level <sup>2</sup>	The chiller will wait up to 2 minutes in this mode for oil level to appear in the oil tank.
Cond Water Pump PreRun Time <sup>2</sup> min:sec	The chiller will wait up to 30 minutes (user adjustable) in this mode to allow the condenser water loop to equalize in temperature

1 - Top Level Mode

2 - Sub Level Mode



# Operator Interface Controls

**Table 18 Operating Modes**

<b>Chiller Modes</b>	<b>Description</b>
Compressor Restart Inhibit Time <sup>2</sup> min:sec	The compressor is currently unable to start due to its restart inhibit timer. A given compressor is not allowed to start until 5 minutes (adj) has expired since its last start.
Waiting For EXV Preposition <sup>2</sup>	The Chiller will wait for the time it takes the EXV to get to its commanded pre-position prior to starting the compressor. This is typically a relatively short delay and no countdown timer is necessary (less than 15 seconds).
Running <sup>1</sup>	The chiller, circuit, and compressor are currently running. Further information is provided by the sub-mode:
Unit is Building Ice <sup>2</sup>	The chiller is running in the Ice Building Mode, and either at or moving towards full capacity available. Ice mode is terminated either with the removal of the ice mode command or with the return brine temperature falling below the Ice Termination Setpoint.
Establishing Min Capacity - High Disch Temp <sup>2</sup>	The compressor is running and is being forced loaded, without regard to the leaving water temperature control, to prevent tripping on high compressor discharge temperature.
Base Loaded <sup>2</sup>	Chiller is running in "Base Load" operation where the capacity of the chiller is controlled to maintain a given current per an adjustable set point. The chiller is forced to run without regard to the chilled water temperatures and the differential to start and stop.
Capacity Control Softloading <sup>2</sup>	The chiller is running, but loading is influenced by a gradual 'pulldown" filter on the chilled water temperature setpoint. The settling time of this filter is user adjustable as part of the softload control feature.
Current Control Softloading <sup>2</sup>	The chiller is running, but loading is influenced by a gradual filter on the current limit setpoint. The starting current and the settling time of this filter is user adjustable as part of the softload control feature.
EXV Controlling Differential Pressure <sup>2</sup>	Liquid level control of the Electronic Expansion Valve has temporarily been suspended. The EXV is being modulated to control for a minimum differential pressure. This control implies low liquid levels and higher approach temperatures, but is necessary to provide minimum oil flow for the compressor until the condenser water loop can warm up to approx 50F.
Running - Limited <sup>1</sup>	The chiller, circuit, and compressor are currently running, but the operation of the chiller/compressor is being actively limited by the controls. Further information is provided by the sub-mode.
Capacity Limited by High Cond Press <sup>2</sup>	The circuit is experiencing condenser pressures at or near the condenser limit setting. The compressor will be unloaded to prevent exceeding the limits.
Capacity Limited by Low Evap Rfgr Temp <sup>2</sup>	The circuit is experiencing saturated evaporator temperatures at or near the Low Refrigerant Temperature Cutout setting. The compressors will be unloaded to prevent tripping.

1 - Top Level Mode  
2 - Sub Level Mode

# Operator Interface Controls

**Table 18 Operating Modes**

<b>Chiller Modes</b>	<b>Description</b>
Capacity Limited by Low Liquid Level <sup>2</sup>	The circuit is experiencing low refrigerant liquid levels and the EXV is at or near full open. The compressor will be unloaded to prevent tripping.
Capacity Limited by High Current <sup>2</sup>	The compressor is running and its capacity is being limited by high currents. The current limit setting is 120% RLA (to avoid overcurrent trips).
Capacity Limited by Phase Unbalance <sup>2</sup>	The compressor is running and its capacity is being limited by excessive phase current unbalance.
Note: Other normal running modes (see above) may also appear under this top level mode.	
Shutting Down <sup>1</sup>	The chiller is still running but shutdown is imminent. The chiller is going through a compressor run-unload sequence. Shutdown is necessary due to one (or more) of the following sub-modes:
Local Stop <sup>2</sup>	Chiller is in the process of being stopped by DynaView Stop button command.
Panic Stop <sup>2</sup>	Chiller is in the process of being stopped by DynaView Panic Stop command.
Diagnostic Shutdown - Manual Reset <sup>2</sup>	Chiller is in the process of being stopped by a Latching Diagnostic shutdown - Manual Reset is required to clear.
Diagnostic Shutdown - Auto Reset <sup>2</sup>	Chiller is in the process of being stopped by a Diagnostic shutdown - Automatic clearing of the diagnostic is possible if condition clears.
Compressor Unloading <sup>2</sup> min:sec	The compressor is in its "run - unload" state in which it is being continuously unloaded for 40 sec prior to shutdown.
Start Inhibited by External Source <sup>2</sup>	Chiller is in the process of being stopped by the External Stop hardwired input.
Start Inhibited by BAS <sup>2</sup>	The Chiller is in the process of shutdown due to a command from the Building Automation System (e.g. Tracer).
Ice Building to Normal Transition <sup>2</sup>	Chiller is in the process of being stopped by the transition from ice to normal cooling mode with the removal of the ice making command via the hardwired input or Building Automation System (e.g. Tracer).
Ice Building is Complete <sup>2</sup>	Chiller is in the process of being stopped as the Ice Building process is being normally terminated on the return brine temperature.
Evap Pump Off Delay <sup>2</sup> min:sec	
Service Override <sup>1</sup>	The Chiller is in a Service Override mode
Service Pumpdown <sup>2</sup>	The chiller, circuit, and compressor is running via a manual command to perform a Service Pumpdown. Both evap and condenser water pumps are commanded to run. The EXV is held wide open, but the manual liquid line service valve should be closed.

1 - Top Level Mode  
2 - Sub Level Mode

# Operator Interface Controls

## Reports Screen

The Reports tab allows a user to select from a list of reports headings. Each report will generate a list of status items as defined in the tables that follow.

**Figure 28. Reports Screen**

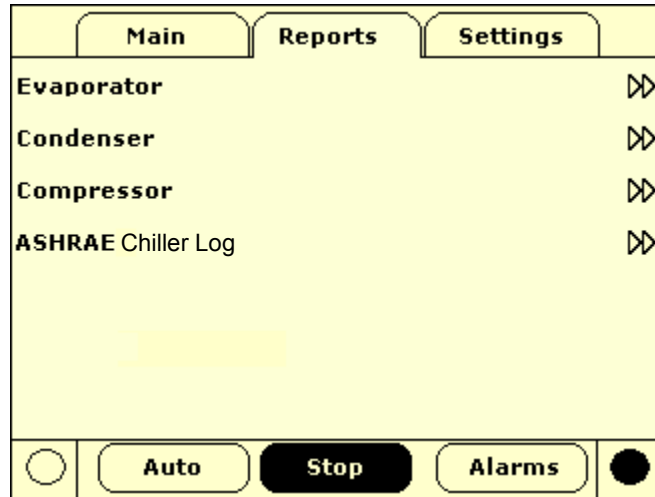

**Table 19 Report Screen Items**

Description	Resolution	Units
<b>Evaporator</b>		
Evap Entering Water Temp	± XXX.X	F / C
Evap Leaving Water Temp	± XXX.X	F / C
Evap Sat Rfgt Temp	± XXX.X	F / C
Evap Rfgt Pressure	XXX.X	psi / kPa
Evap Approach	± XXX.X	F / C
Evap Water Flow Switch Status	(Flow, No Flow)	Text
Expansion Valve Position	XXX.X	Percent
Expansion Valve Position Steps	XXXX	Steps
Evaporator Liquid Level	X.X	in / mm
<b>Condenser</b>		
Cond Entering Water Temp	± XXX.X	F / C
Cond Leaving Water Temp	± XXX.X	F / C
Cond Sat Rfgt Temp	± XXX.X	F / C
Cond Rfgt Pressure	XXX.X	psi / kPa
Cond Approach Temp	± XXX.X	F / C
Cond Water Flow Switch Status	(Flow, No Flow)	Text
Cond Head Pressure Ctrl Command	XXX	%



# Operator Interface Controls

**Table 19 Report Screen Items**

<b>Description</b>	<b>Resolution</b>	<b>Units</b>
Outdoor Air Temperature	± XXX.X	F / C
<b>Compressor</b>		
Compressor Starts	XXXX	Integer
Compressor Running Time	XXXX:XX	hr:min
System Rfgt Diff Pressure	XXX.X	psi / kPa
Oil Pressure	XXX.X	psi / kPa
Compressor Rfgt Discharge Temp	± XXX.X	F / C
Discharge Superheat	± XXX.X	F / C
% RLA L1 L2 L3	XXX.X	Percent RLA
Amps L1 L2 L3	XXXX	Amps
Volts AB BC CA	XXXX	Volts
<b>ASHRAE Chiller Log</b>		
Current Time/Date	XX:XX mmm dd, yyyy	Date / Time
Operating Mode:		Text
Amps L1 L2 L3	XXXX	Amps
Volts AB BC CA	XXXX	Volts
Active Chilled Water Setpoint	XXX.X	F / C
Active Current Limit Setpoint	XXX.X	F / C
Refrigerant Monitor	XXX.X	Ppm
Compressor Starts	XXXX	Integer
Compressor Running Time	XX:XX	Hours:Minute
Compressor Rfgt Discharge Temp	XXX.X	F / C
Evap Entering Water Temp	XXX.X	F / C
Evap Leaving Water Temp	XXX.X	F / C
Evap Sat Refrigerant Temp	XXX.X	F / C
Evap Rfgt Pressure	XXX.X	psi / kPa
Evap Approach Temp:	XXX.X	F / C
Evap Water Flow Switch Status		Text
Cond Entering Water Temp	XXX.X	F / C
Cond Leaving Water Temp	XXX.X	F / C
Cond Sat Rfgt Temp	XXX.X	F / C
Cond Rfgt Pressure	XXX.X	psi / kPa
Condenser Approach Temp	XXX.X	F / C
Cond Water Flow Switch Status		Text

# Operator Interface Controls

## Settings Screen

The Settings screen provides the user the ability to adjust settings. The layout provides a list of sub-menus, organized by typical subsystem.

Figure 29. Settings Screen

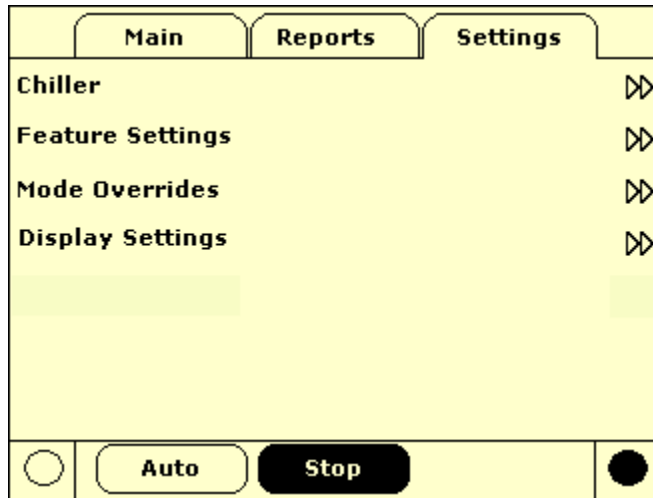

Table 20 Settings Screen Items

Description	Resolution or (Text), Default	Units
<b>Chiller</b>		
Front Panel Chilled Water Setpt	± XXX.X	(3)
Front Panel Current Limit Setpt	XXX (4)	Percent RLA
Front Panel Base Load Cmd	On/Auto	Text
Front Panel Base Load Setpt	XXX	Percent
Front Panel Ice Build Cmd	On/Auto	Text
Front Panel Ice Termn Setpt	XXX.X	F / C
Ice to Normal Cool Timer Setpt	(0-10), 5 min	Minutes
Differential to Start	XXX.X	F / C
Differential to Stop	XXX.X	F / C
Setpoint Source	(BAS/Ext/FP, Ext/ Front Panel, Front Panel), BAS/Ext/FP	Text
<b>Features</b>		
Chilled Water Reset	(Constant, Outdoor, Return, Disable), Disable	Text
Return Reset Ratio	XXX	Percent
Return Start Reset	XXX.X	F / C
Return Maximum Reset	XXX.X	F / C



# Operator Interface Controls

**Table 20 Settings Screen Items**

<b>Description</b>	<b>Resolution or (Text), Default</b>	<b>Units</b>
Outdoor Reset Ratio	XXX	Percent
Outdoor Start Reset	XXX.X	F / C
Outdoor Maximum Reset	XXX.X	F / C
Ext Chilled Water Setpoint	(Enable, Disable), Disable	Text
Ext Current Limit Setpoint	(Enable, Disable), Disable	Text
Ice Building	(Enable, Disable), Disable	Text
Ext Base Loading Setpoint	(Enable, Disable), Disable	Text
<b>Mode Overrides</b>		
Evap Water Pump	(Auto, On), Auto	Text
Cond Water Pump	(Auto, On), Auto (8)	Text
Expansion Valve Control	(Auto, Manual) Auto	Text
Slide Valve Control	(Auto, Manual) Auto	Text
Service Pumpdown	Status: (Avail, Not Avail, Pumpdown)	Text
<b>Display Settings</b>		
Date Format	("mmm dd, yyy", "dd-mmm-yyyy"), "mmm dd, yyy"	Text
Date		Text
Time Format	(12-hour, 24-hour), 12-hour	Text
Time of Day		Text
Keypad/Display Lockout	(Enable, Disable), Disable (5)	Text
Display Units	(SI, English) English	Text
Pressure Units	(Absolute, Gauge), Absolute	Text
Language Selection	Downloaded from TechView	Text

# Operator Interface Controls

## Diagnostic Screen

Figure 30. Diagnostics Screen

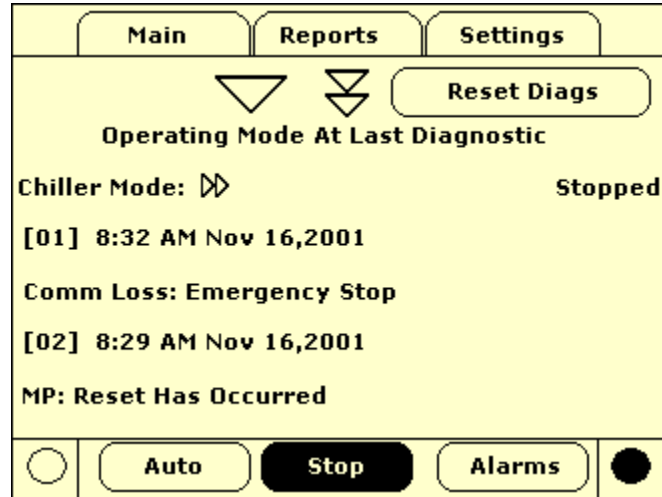

The diagnostic screen is accessible by depressing the Alarms enunciator. A verbal description will be provided.

A scrollable list of the last (up to 10) active diagnostics is presented. Performing a "Reset Diags" will reset all active diagnostics regardless of type, machine or circuit. The scrollable list will be sorted by time of occurrence.

If a informational warning is present, the "Alarms" key will be present but not flashing. If a diagnostic shutdown (normal or immediate) has occurred, the "Alarm" key will display that is flashing. If no diagnostics exist, the "Alarm" key will not be present.

The "Operating Mode At Last Diagnostic" text above the most recent diagnostic will display a sub-screen listing the operating mode and submodes at the time of the last diagnostic.

# TechView

---



TechView is the PC (laptop) based tool used for servicing Tracer CH530 Chillers. Technicians that make any chiller control modification or service any diagnostic with Tracer CH530 must use a laptop running the software application "TechView." TechView is a Trane application developed to minimize chiller downtime and aid the technicians' understanding of the chiller operation and service requirements.

*NOTE: Important: Performing any Tracer CH530 service functions should be done only by a properly trained service technician. Please contact your local Trane service agency for assistance with any service requirements.*

TechView software is available via Trane.com.

(<http://www.trane.com/commercial/software/tracerch530/>)

This download site provides a user the TechView installation software and CH530 main processor software that must be loaded onto their PC in order to service a CH530 main processor. The TechView service tool is used to load software into the Tracer CH530 main processor.



# TechView

---

## Minimum PC requirements to install and operate TechView

- Pentium II or higher processor
- 128Mb RAM
- 1024 x 768 resolution of display
- 56K modem
- 9-pin RS-232 serial connection
- Operating system - Windows 2000
- Microsoft Office (MS Word, MS Access, MS Excel)
- Parallel Port (25-pin) or USB Port

*NOTE: TechView was designed for the preceding listed laptop configuration. Any variation will have unknown results. Therefore, support for TechView is limited to only those operating systems that meet the specific configuration listed here. Only computers with a Pentium II class processor or better are supported; Intel Celeron, AMD, or Cyrix processors have not been tested.*

TechView is also used to perform any CH530 service or maintenance function. Servicing a CH530 main processor includes:

- Updating main processor software
- Monitoring chiller operation
- Viewing and resetting chiller diagnostics
- Low Level Intelligent Device (LLID) replacement and binding
- Main processor replacement and configuration modifications
- Setpoint modifications
- Service overrides

# TechView

## Unit View

Unit view is a summary for the system organized by chiller subsystem. This provides an overall view of chiller operating parameters and gives you an "at-a-glance" assessment of chiller operation.

Upon successful Local Connect Tech View will display UNIT VIEW.

RTHD Unit View is shown below

Figure 31 Unit View

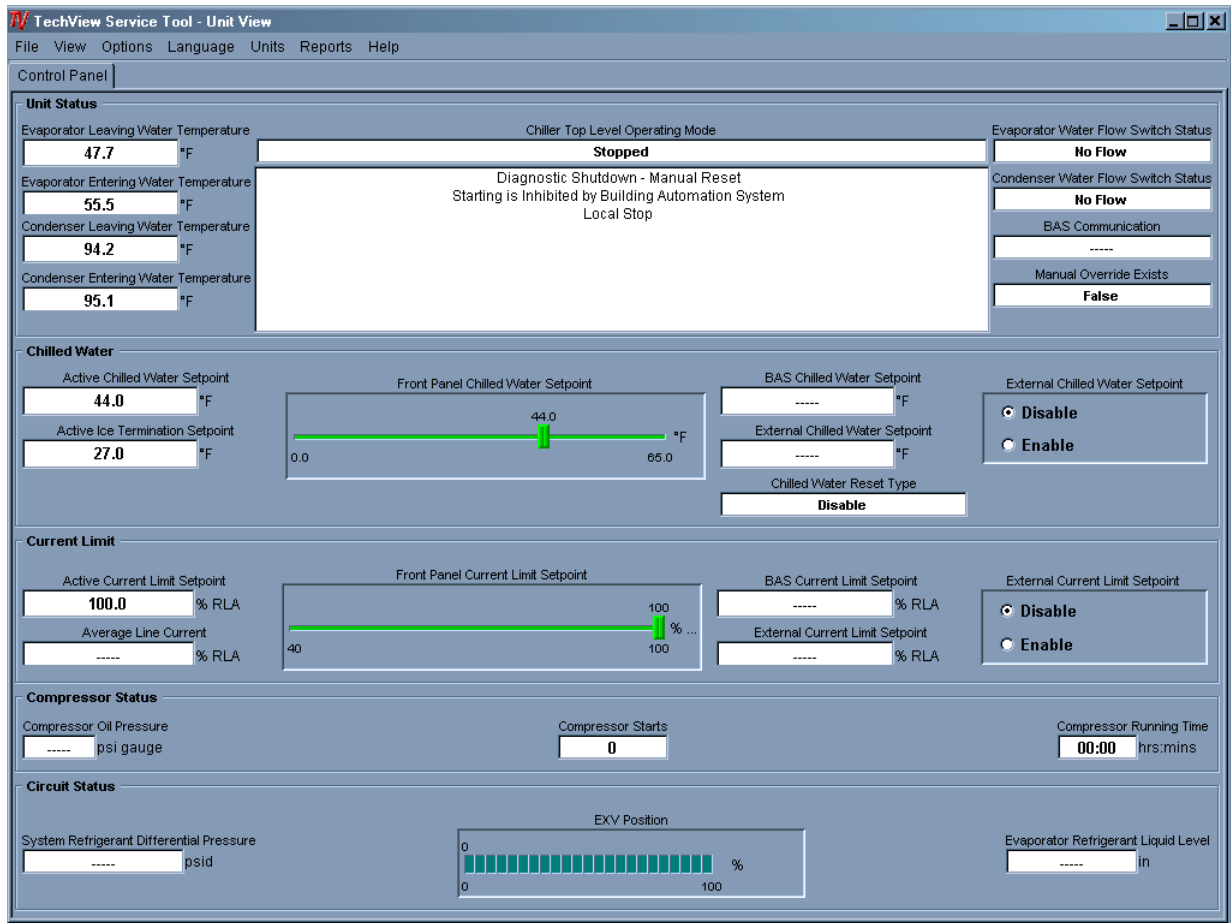



# TechView

## Status View

Status View displays, in real time, all non-setpoint data organized by subsystem tabs. As data changes on the chiller it is automatically updated in Status View

Figure 32. Status View

The screenshot shows the 'TechView Service Tool - Status View' window. It features a menu bar (File, View, Options, Language, Units, Reports, Help) and a tabbed interface with 'Chiller' selected. The main content is a table with columns for 'Readout', 'Reading', 'Max', and 'Min'. The table lists various chiller parameters and their current status.

Readout	Reading	Max	Min
Active Chilled Water Setpoint	44.0 °F	44.0	44.0
Active Chilled Water Setpoint Source	Front Panel		
Active Current Limit Setpoint	100.0 % RLA	100.0	100.0
Active Current Limit Setpoint Source	Front Panel		
Active Base Loading Setpoint	50.0 %	50.0	50.0
Active Base Loading Setpoint Source	Front Panel		
Active Ice Termination Setpoint	27.0 °F	27.0	27.0
Active Ice Termination Setpoint Source	Front Panel		
Evaporator Entering Water Temperature	----	----	----
Evaporator Leaving Water Temperature	----	----	----
Chilled Water Pump Relay	On		
Evaporator Water Flow Switch Status	No Flow		

# TechView

**Table 21 Status View Items**

Tab	Text	Units
Chiller	Active Chilled Water Setpoint / Source	Temperature
	Active Current Limit Setpoint / Source	Percent RLA
	Active Base Loading Setpoint / Source	Percent
	Active Ice Termination Setpoint / Source	Temperature
	Evaporator Entering Water Temperature	Temperature
	Evaporator Leaving Water Temperature	Temperature
	Chilled Water Pump Relay	(on/off)
	Evaporator Water Flow Switch Status	(Flow/NoFlow)
	Condenser Entering Water Temperature	Temperature
	Condenser Leaving Water Temperature	Temperature
	Condenser Water Pump Relay	(on/off)
	Condenser Water Flow Switch Status	(Flow/NoFlow)
	Outdoor Air Temperature	Temperature
	Refrigerant Monitor	Ppm
Circuit	Evaporator Saturated Refrigerant Temperature	Temperature
	Evaporator Refrigerant Pressure	Pressure
	Evaporator Approach Temperature	Diff. Temperature
	Evaporator Liquid Level	Level
	Condenser Saturated Refrigerant Temperature	Temperature
	Condenser Refrigerant Pressure	Pressure
	Condenser Approach Temperature	Diff. Temperature
	Discharge Superheat	Diff. Temperature
	Expansion Valve Position	Percent
	Expansion Valve Position Steps	Steps
	HPC Switch Status	(Closed/Tripped)



# TechView

**Table 21 Status View Items**

Tab	Text	Units	
Compressor	Compressor Running Status	(On/Off)	
	Compressor Starts	Integer	
	Compressor Run Time	Hrs:mins	
	Compressor Refrigerant Discharge Temp	Temperature	
	Oil Return Gas Fill Solenoid Valve Status	(Open/Closed)	
	Oil Return Gas Drain Solenoid Valve Status	(Open/Closed)	
	Oil Loss Level Sensor	(Dry/Wet)	
	Oil Pressure	Pressure	
	Oil Pressure Ratio	Pressure Ratio- Psid/Psid or Kpa/Kpa	
	System Refrigerant Differential Pressure	Diff Pressure	
	Restart Inhibit Time Remaining	Min:sec	
	Line Current L1, L2, L3	Percent RLA	
	Line Current L1, L2, L3	amps	
	Phase Voltage AB BC CA	volts	
	Average Line Current	Percent RLA	
	Average Line Current	amps	
	Maximum Line Current	Percent RLA	
	Average Phase Voltage	volts	
	Condenser Head Pressure (optional)	Flow Commanded	Percent
		Output Voltage Commanded	Voltage
Modes	Chiller Top Level Mode	Text	
	Chiller Sub Modes	Text	
	Chiller Mode at Time of Last Diagnostic	Text	
	Chiller Sub Modes at Time of Last Diagnostic	Text	



# TechView

## Setpoint View

Setpoint view displays the active setpoints and allows you to make changes.

Figure 33 Setpoint View



### Setpoint List

The center of the window displays the scrollable list of setpoint panels.

### Setpoint Enumeration Panel

A setpoint numeric panel contains a label with the setpoint description and a pull-down list showing the active value and the other selections. The Default button returns the setpoint to the product's factory setting. The text field is updated when the change is complete.

# TechView

## Setpoint Numeric Panel

A setpoint numeric panel contains a label with the setpoint description, a Default button, a text field with a unit label, and a slider.



The Default button changes the setpoint to the product's factory setting. The text field and slider are updated when the change is complete.

You can change a setpoint with the text field or with the slider. When you click on the entry field, the change setpoint dialog displays to coordinate the setpoint change.

You can change the display units for a setpoint by clicking on the unit label next to the entry field. Only units that have different English and SI values can be modified.

## Change Setpoint

The change setpoint window allows you to enter a new value for the setpoint into a text field. If the entered value is outside the given range, the background turns red.

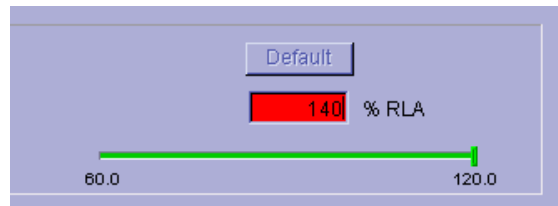

# TechView

**Table 22 Setpoint View Items**

Tab	Setpoint	(Min, Max), Default	Units
Chiller	Front Panel Chilled Water Setpoint	(-17.78, 18.33), 6.67 °C	Temperature
	Front Panel Current Limit Setpoint	(40, 100), 100 %RLA	Percent RLA
	Front Panel Ice Building Command	On/auto	Enum
	Front Panel Ice Termination Setpoint	(-6.67, 0.0), -2.78 °C	Temperature
	Ice To Normal Cooling Timer	(0-10), 5 min	Minutes
	Front Panel Base Loading Command	On/auto	Enum
	Front Panel Base Loading Setpoint	(40-100),50	Percent
	Differential to Start Setpoint	(0.55, 5.55), 2.78 °C	Diff Temperature
	Differential to Stop Setpoint	(0.55, 5.55), 2.78 °C	Diff Temperature
	Setpoint Source	(BAS/Ext/FP, Ext Front Panel, Front Panel), BAS/Ext/FP	Enum
	Power Up Start Delay	(0, 600), 0 sec	Seconds
	Evaporator Water Pump Off Delay	(0, 30), 1 min	Minutes
	Condenser Pump Prestart Time	(0, 30), 0 min	Minutes
	Evaporator Design Delta Temperature	(2.22, 16.7), 5.56 °C	Diff Temperature
	Evaporator Leaving Water Temperature Cutout	(-18.33, 2.22), 2.22 °C "Warning: Adequate Antifreeze Required <1.83°C	Temperature
	Low Refrigerant Temp Cutout	(-20.55, 2.22), -1.89 °C "Warning: Adequate Antifreeze Required <-1.94°C	Temperature
	Condenser High Refrigerant Pressure Setting	(80, 120), 90 %HPC	Percent HPC
	High Evap Water Temp Cutout	(26.6 , 65.5°C), 40.5°C	Temperature
	Restart Inhibit Free Starts	(1, 5), 3	Starts
	Restart Inhibit Start to Start Time	(5, 30), 10 min	Minutes
Restart Inhibit Diagnostic	(Enable Disable), Enable	Enum	
Local Atmospheric Pressure	(68.95, 110.32), 101.35 kPa (absolute)	Pressure	
Head Relief Relay Filter Time	(1-60),10		

Min, Max and Default values are shown in SI units

# TechView

**Table 22 Setpoint View Items**

<b>Tab</b>	<b>Setpoint</b>	<b>(Min, Max), Default</b>	<b>Units</b>
Feature Settings	Chilled Water Reset	(Constant, Outdoor, Return, Disable), Disable	Enum
	Return Reset Ratio	(10, 120), 50 %	Percent
	Return Start Reset	(2.22, 16.67), 5.56 °C	Diff Temperature
	Return Max Reset	(0.0, 11.11), 2.78 °C	Diff Temperature
	Outdoor Reset Ratio	(-80, 80), 10 %	Percent
	Outdoor Start Reset	(10, 54.44), 32.22 °C	Temperature
	Outdoor Max Reset	(0.0, 11.11), 2.78 °C	Diff Temperature
	External Chilled Water Setpoint	(Enable, Disable), Disable	Enum
	External Current Limit Setpoint	(Enable, Disable), Disable	Enum
	Ice Building Feature	(Enable, Disable), Disable	Enum
	External Base Loading Setpoint Enable	(Enable, Disable), Disable	Enum
	Capacity Control Softloading Time	(0, 7200), 900 sec	Seconds
	Current Limit Control Softloading Time	(0, 7200), 600 sec	Seconds
	Current Limit Softload Start Point	(40, 100), 40 %RLA	Percent RLA
	Phase Unbalance Limit Protection	(Enable, Disable), Enable	Enum
Over/Under Voltage Protection	(Enable, Disable), Disable	Enum	
Condenser Head Pressure (optional)	"Off State" Output Command	(0.0-10.0), 2.0 Volts	Voltage
	Output Voltage at Desired Minimum Flow	(0.0 - 10.0) 2.0 Volts	Voltage
	Desired Minimum Flow	(0-100), 20 %	Percent
	Output Voltage at Desired Maximum Flow	(0.0 - 10.0), 2.0 Volts	Voltage
	Actuator Stroke Time	(0.0 - 300) 30 Sec	Seconds
	Damping Coefficient	(0.1 - 1.8) 0.5	None

Min, Max and Default values are shown in SI units

# TechView

## Manual Override View

Manual Override View is a combined presentation of setpoint (override) and status values. Each manual override item has an "Auto / On" (or Off) for binary control values or an "Auto/Manual" and an analog target value. Additionally, each item has a monitor value that the user will track the effect of an override.

Figure 34. Manual Override View

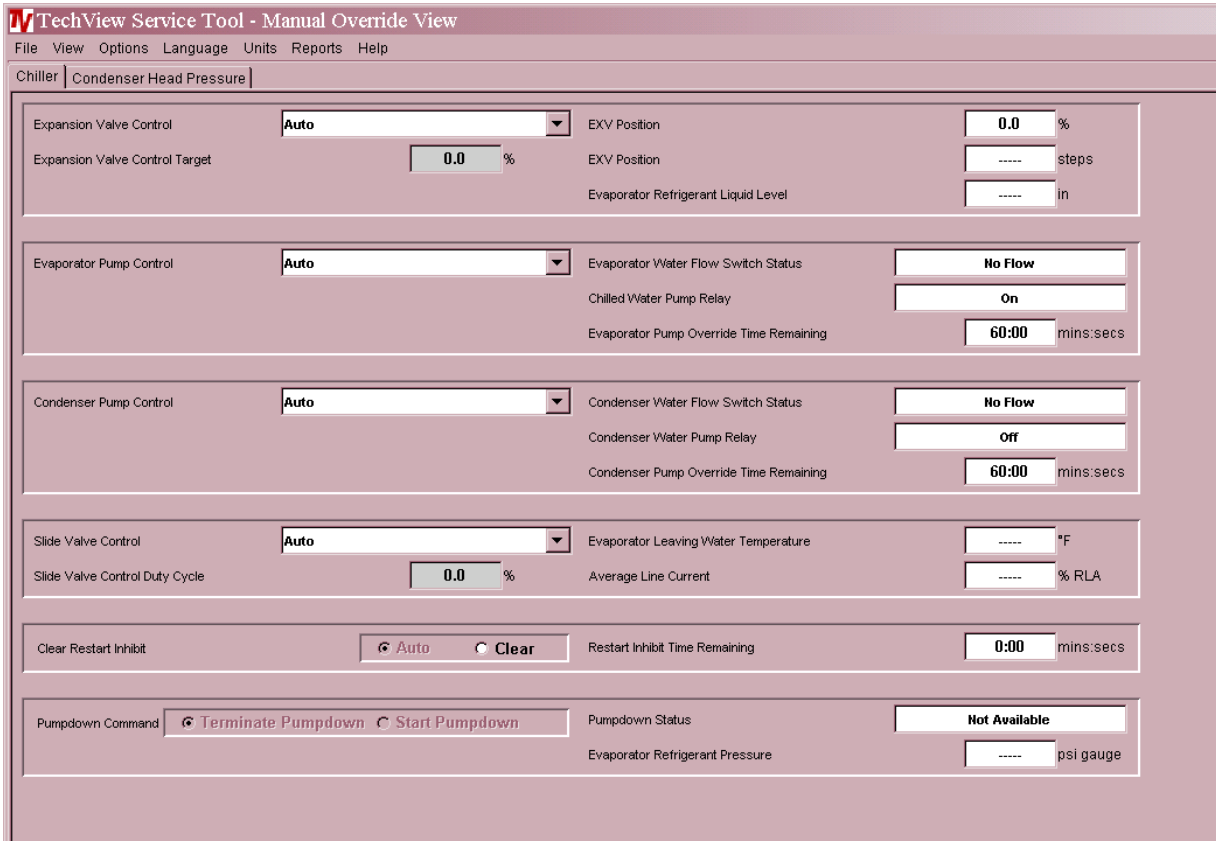

The panel contents are described as follows:

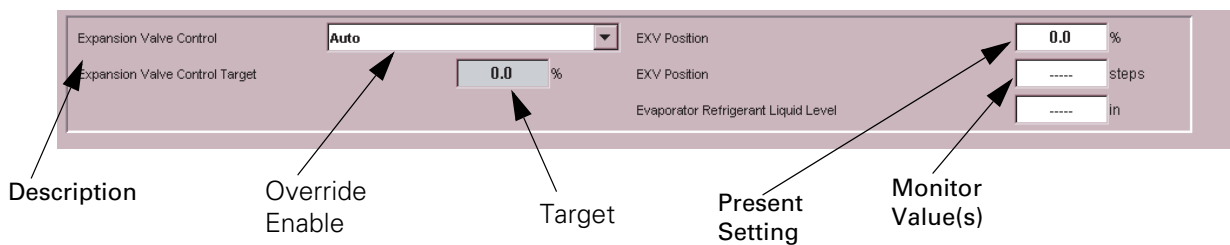



# TechView

**Table 23** Manuel Override View

<b>Description</b>	<b>Radio 1</b>	<b>Radio 2</b>	<b>Monitor Value(s): Attribute ID</b>
Expansion Valve Control (%)	Auto	Manual Expansion Valve Control Target	EXV Position (%) EXV Position (steps) Evaporator Liquid Level (inches)
Evaporator Pump Control	Auto	On	Evap Water Flow Switch Status: Chilled Water Pump Relay: Evap Pump Override Time Remaining:
Condenser Pump Control	Auto	On	Cond Water Flow Switch Status: Condenser Water Pump Relay: Cond Pump Override Time Remaining
Slide Valve Control (Slide Valve Control Duty Cycle)	Auto	Manual  Rate* integers -100 to +100	Evaporator Leaving Water Temperature Average Line Current (%RLA)  <b>Note:</b> <b>positive integers 1 to 100 imply loading at that duty cycle(5 sec period)</b>  <b>negative integers -1 to -100 imply unloading at that absolute value duty cycle</b>  <b>0 implies hold</b>
Pumpdown Command and Pumpdown Status	Start  Available Not Available In Progress Inhibited	Abort	Evaporator Refrigerant Pressure
Restart Inhibit Timer	Clear (Button)		Time Remaining
Head Pressure Control Override	0= Auto 1= Off 2= Minimum 3=Maximum	"Off State" Output Command Output Voltage at Desired Minimum Flow Desired Minimum Flow Output Voltage at Desired Maximum Flow Actuator Stroke Time Damping Coefficient Condenser Water Pump Prestart Time	Leaving Condenser Water Temperature Leaving Condenser Water Temperature Condenser Water Pump Flow Status Output Voltage Commanded Flow Commanded Time to Get to Commanded Position

# TechView

## Diagnostics View

This window lists the active and inactive (history) diagnostics. There can be up to 60 diagnostics, both active and historic. For example, if there were 5 active diagnostics, the possible number of historic diagnostics would be 55. You can also reset active diagnostics here, (i.e., transfer active diagnostics to history and allow the chiller to regenerate any active diagnostics).

Resetting the active diagnostics may cause the chiller to resume operation.

The Active and History diagnostics have separate tabs. A button to reset the active diagnostics displays when either tab is selected

**Figure 35. Diagnostics View**

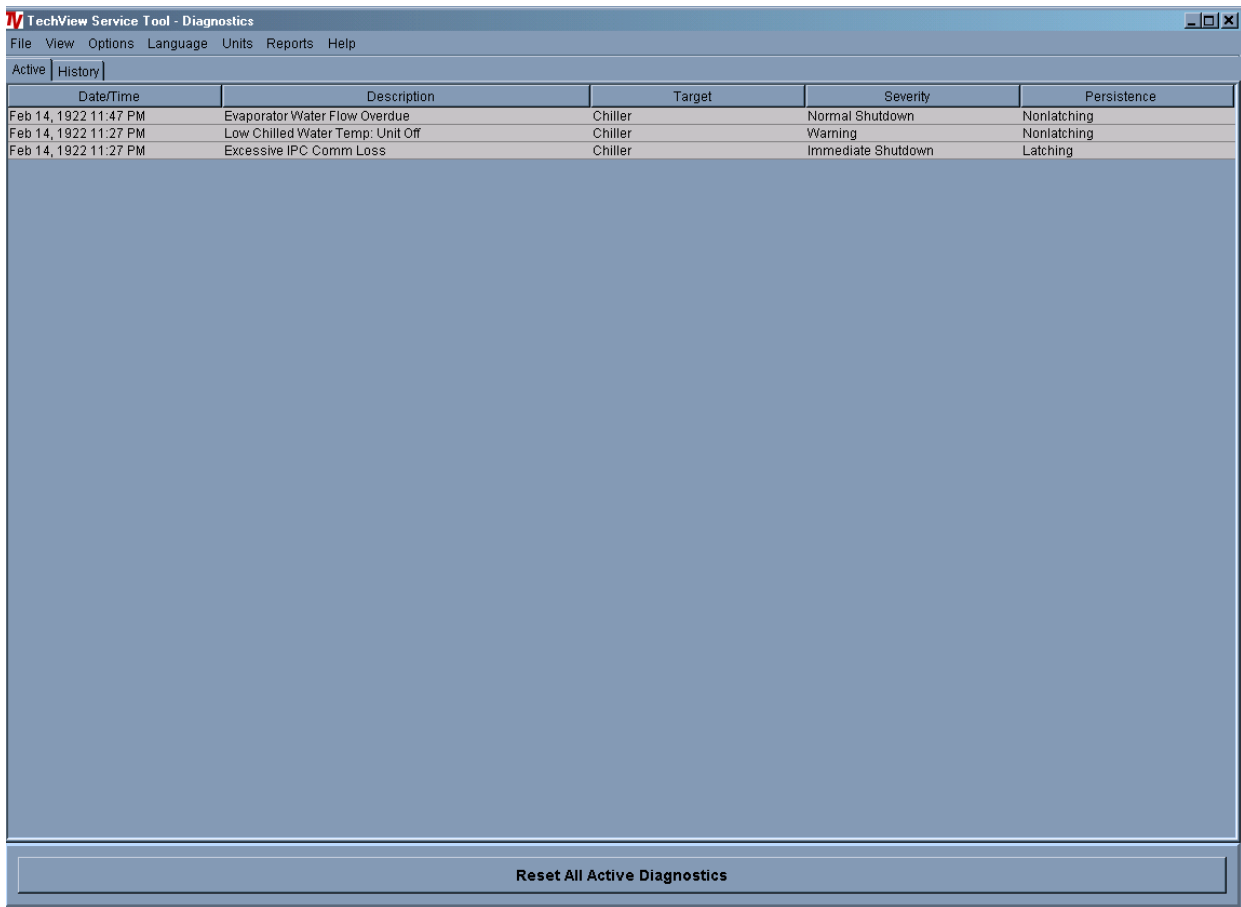

# TechView

## Configuration View

Configuration view displays the active configuration and allows you to make changes.

**Figure 36** Configuration View

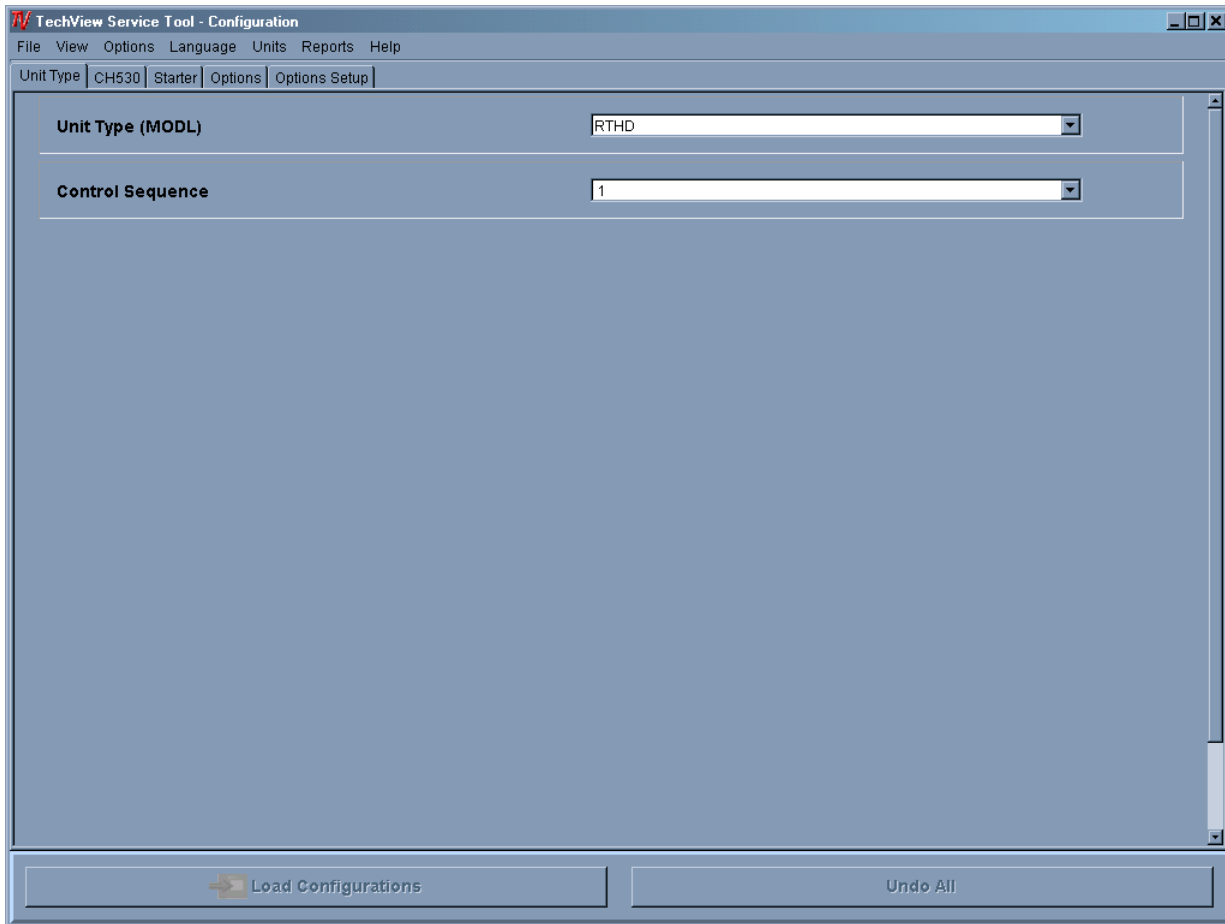

Configuration View allows you to define the chiller's components, ratings, and configuration settings. These are all values that determine the required installed devices, and how the chiller application is run in the main processor. For example, a user may set an option to be installed with Configuration View, which will require devices to be bound using Binding View. And when the main processor runs the chiller application, the appropriate steps are taken to monitor required inputs and control necessary outputs.

Any changes made in the Configuration View, on any of the tabs, will modify the chiller configuration when you click on the Load Configuration button (located at the base of the window). The Load Configuration button uploads the new configuration settings into the main processor.

Note: Selecting the Undo All button will undo any configuration setting changes made during the present TechView connection and since the last time the Load Configuration button was selected





# TechView

**Table 24 Configuration View Items**

Tab	Description	Setting	Notes	
Unit Type	Unit Type (MODL)	RTHD		
	Control Sequence	1		
CH530	Chiller Design Sequence**	A0, B0, C0, D0, etc.	See Nameplate	
	Electronic Expansion Valve - Actuators	SNGL (single), DUAL (dual)	If COMP=B* then SNGL	
	Evaporator Size	B1, B2, C1, C2, D1, D2, D3, D4, D5, E1, F1, F2, G1, G2, G3		
	Condenser High Pressure Cutout	35 to 3450	1240	
	Unit Line Voltage	180 to 600	See Nameplate	
	Motor NP Hertz	50 or 60	If VOLT= R, T, or U then 50	
	Line Voltage Sensing	not installed, installed		
Starter	Rated Load Amps	34 to 999	See Nameplate	
	Current Transformer (CT) Meter Scale	50, 75, 100, 150, 200, 275, 400, 500, 700, 1000	RLA	CT Meter Scale
			33.4-50	50
			50-75	75
			67-100	100
			100-150	150
			134-200	200
			184-275	275
			267-400	400
			334-500	500
			467-700	700
	667-1000	1000		
	Starter Type	wye-delta, solid state		
	Contactors Integrity Test	enable, disable		
Momentary Power Loss Protection	enable, disable	Must have line voltage sensing option to enable.		
Compressor Frame Size	B1, B2, C1, C2, D1, D2, D3, E3			
Phase Reversal Protection	enable, disable			
Current Imbalance Trip Point	15 to 90	30		
Current Imbalance Grace Period	30 to 255	90		
Maximum Acceleration Time	3 to 10	Comp	Max Accel Time	
		B1	3	
		B2	3	
		C1	5	
		C2	5	
		D1	6	
		D2	6	
D3	6			
E3	6			
Acceleration Timeout Action	shutdown, transition			



# TechView

**Table 24 Configuration View Items**

<b>Tab</b>	<b>Description</b>	<b>Setting</b>	<b>Notes</b>	
Options	Outdoor Air Temperature	not installed, installed		
	Ice Building Option	not installed, installed w/hdwr, installed w/o hdwr		
	External Chilled Water Setpoint	not installed, 2-10 Volts, 4-20 mA		
	External Current Limit Setpoint	not installed, 2-10 Volts, 4-20 mA		
	Base Loading	not installed, 2-10 Volts, 4-20 mA		
	Motor Current Analog Output (%RLA)	not installed, installed		
	Refrigerant Monitor Type	not installed, 4-20 mA, 100 ppm, 4-20 mA, 1000 ppm, 2-10 V, 100 ppm, 2-10 V, 1000 ppm		
	Operating Status Programmable Relays	not installed, installed		
	Refrigerant Pressure Output Type (Condenser Pressure, Differential Pressure, or Condenser Water Regulating Valve Analog Output) the latter is also known as Head Pressure Control	NIST (not installed), HPC (condenser pressure in %HPC), DELP (differential pressure), WREG (condenser water regulating control output)		
	Tracer Interface	comm4, LCI-C		
Options Setup	External Chilled Water Setpoint Minimum Temperature	-17.8 to 9.9	-17.8	
	External Chilled Water Setpoint Maximum Temperature	10.0 to 18.4	18.4	
	External Current Limit Setpoint Minimum % RLA	40 to 69	40	
	External Current Limit Setpoint Maximum % RLA	70 to 100	100	
	Programmable Status Relay 1 (J2 - 10,11,12)	NONE, - Latching Alarm, Non-latching Alarm, Alarm (Alarm - Latching or Non-latching Shutdown), Chiller Limit Mode, Compressor Running), Warning, Head Pressure Relief Request, Tracer Controlled Relay		
	Programmable Status Relay 2 (J2 - 7,8,9)			
	Programmable Status Relay 3 (J2 - 4,5,6)			
	Programmable Status Relay 4 (J2 - 1,2,3)			
	Differential Pressure Output Minimum Pressure	0 to 3450	0	
	Differential Pressure Output Maximum Pressure	0 to 3450	1103	
COMM4 Address	32 to 100	65		

# TechView

## Software View

Software view allows you to verify the version of chiller software (MP) currently running on the DynaView and download a new version of chiller software to the DynaView.

You can also select up to two available languages to load into the DynaView. Loading an alternate language file allows the DynaView to display its text in the selected alternate language.

Figure 37. Software View

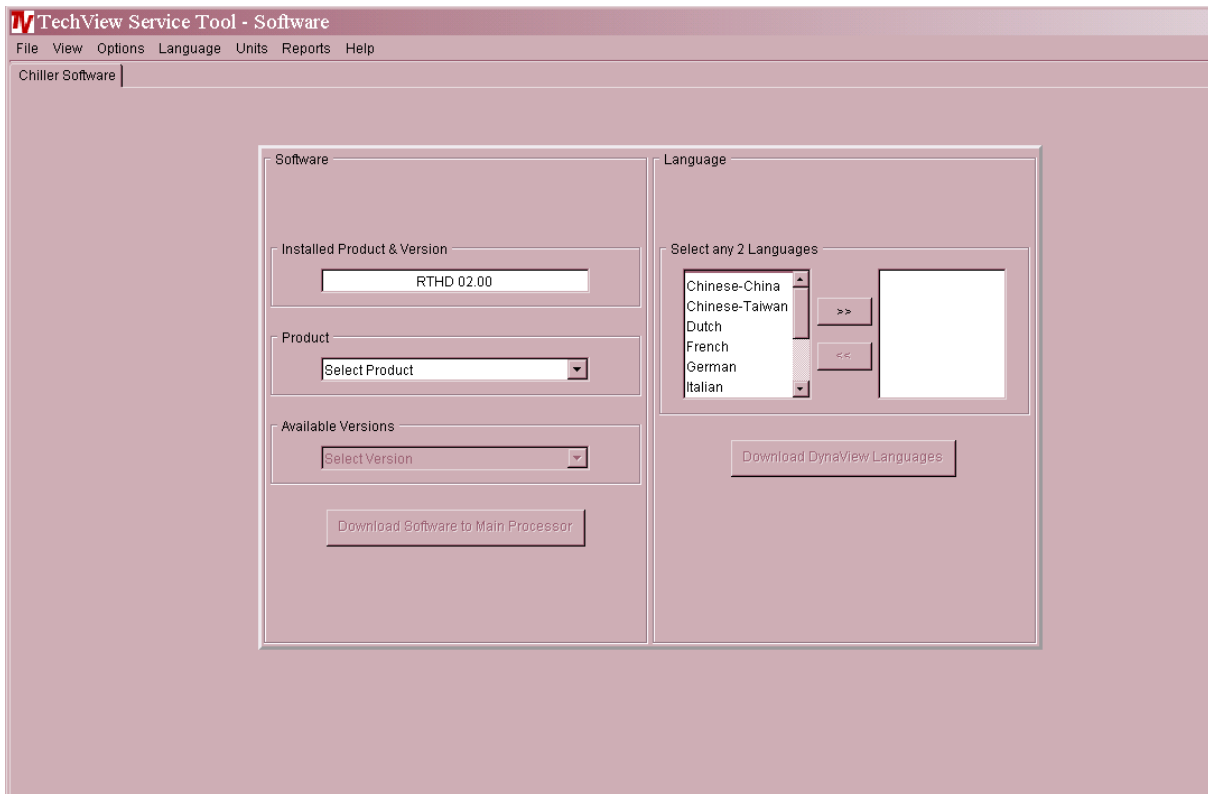

# TechView

## Binding View

Binding View allows you to assess the status of the network and all the devices connected as a whole, or the status of individual devices by using status icons and function buttons.

Binding View is essentially a table depicting what devices and options are actually discovered on the network bus (and their communication status) versus what is required to support the configuration defined by the feature codes and categories. Binding View allows you to add, remove, modify, verify, and reassign devices and options in order to match the configuration requirements.

Whenever a device is installed, it must be correctly configured to communicate and to function as intended. This process is called binding. Some features of Binding View are intended to serve a second purpose; that is diagnosing problems with communication among the devices.

Figure 38. Binding View

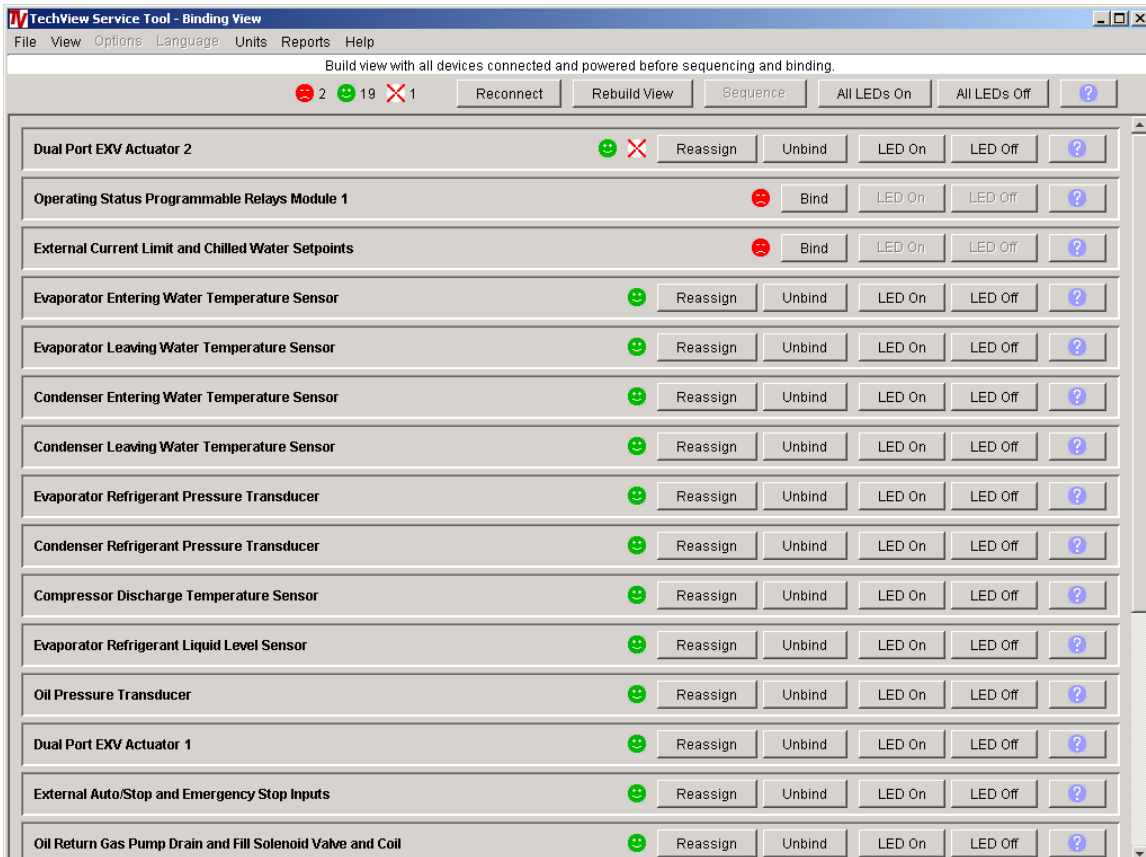

# TechView

---

## Replacing or Adding Devices

If a device is communicating but incorrectly configured, it might not be necessary to replace it. If the problem with the device is related to communication, attempt to rebind it, and if the device becomes correctly configured, it will then communicate properly.

If a device that needs to be replaced is still communicating, it should be unbound. Otherwise, it will be necessary to rebuild the network image for Binding View to discover that it has been removed. An unbound device stops communicating and allows a new device to be bound in its place.

It is good practice to turn the power off while detaching and attaching devices to the network. Be sure to keep power on the service tool computer. After power is restored to the network, the reconnect function in Binding View restores communication with the network. If the service tool computer is turned off, you must restart TechView and Binding View.

If a device is not communicating, the binding function displays a window to request manual selection of the device to be bound. Previously-selected devices are deselected when the function starts. When manual selection is confirmed, exactly one device must be selected; if it is the correct type, it is bound. If the desired device cannot be selected or if multiple devices are accidentally selected, you can close the manual selection window by clicking on No and repeat the bind function.

## Software Download

### Instructions for First Time TechView Users

This information can also be found at <http://www.trane.com/commercial/software/tracerch530/>.

1. Create a folder called "CH530" on your C:\ drive. You will select and use this folder in subsequent steps so that downloaded files are easy to locate.
2. Download the Java Runtime installation utility file onto your PC in the CH530 folder (please note that this does not install Java Runtime, it only downloads the installation utility).
  - Click on the latest version of Java Runtime shown in the TechView Download table.
  - Select "Save this program to disk" while downloading the files (do not select "Run this program from its current location").
3. Download the TechView installation utility file onto your PC in the CH530 folder (please note that this does not install TechView, it only downloads the installation utility).
  - Click on the latest version of TechView shown in the TechView Download table.
  - Select "Save this program to disk" while downloading the files (do not select "Run this program from its current location").
4. Remember where you downloaded the files (the "CH530" folder). You will need to locate them to finish the installation process.
5. Proceed to "Main Processor Software Download" page and read the instructions to download the latest version of main processor installation files.

Note: you will first select the chiller type to obtain the available file versions.



## TechView

---

6. Select the product family. A table with the download link will appear for that product family.
7. Download the main processor software onto your PC in the CH530 folder (please note that this does not install the main processor, it only downloads the installation utility).
  - To do this, click on the latest version of the main processor.
  - Select “Save this program to disk” while downloading the files (do not select “Run this program from its current location”).
8. Remember where you downloaded the files (the “CH530” folder). You will need to locate them to finish the installation process.
9. To complete the installation process, locate the installation utilities you downloaded into the CH530 folder. If necessary, use your PC’s file manager to locate the downloaded files.
10. Install the applications in the following order by double-clicking on the install program and following the installation prompts:
  - Java Runtime Environment (JRE\_VXXX.exe)  
Note: During the Java Runtime Environment installation, you may be prompted to “select the default Java Runtime for the system browsers...”. Do not select any system browsers at this step. There should be no default browsers selected for proper operation.
  - TechView (6200-0347-VXXX.exe)
  - The main processor (6200-XXXX-XX-XX.exe).
  - The main processor program will self extract to the proper folder within the TechView program directory, provided the TechView program is properly installed on the C:\ drive.
11. Connect your PC to the CH530 main processor using a standard 9-pin male/9-pin female RS-232 cable.
12. Run the TechView software by selecting the TechView icon placed on your desktop during the installation process. The “Help...About” menu can be viewed to confirm proper installation of latest versions.

## Unit Start-up

### Power Up

The Power up chart shows the respective DynaView screens during a power up of the main processor. This process takes from 30 to 50 seconds depending on the number of installed Options. On all power ups, the software model will always transition through the 'Stopped' Software state independent of the last mode. If the last mode before power down was 'Auto', the transition from 'Stopped' to 'Starting' occurs, but it is not apparent to the user.

#### RTHD Sequence of Operation: Power Up

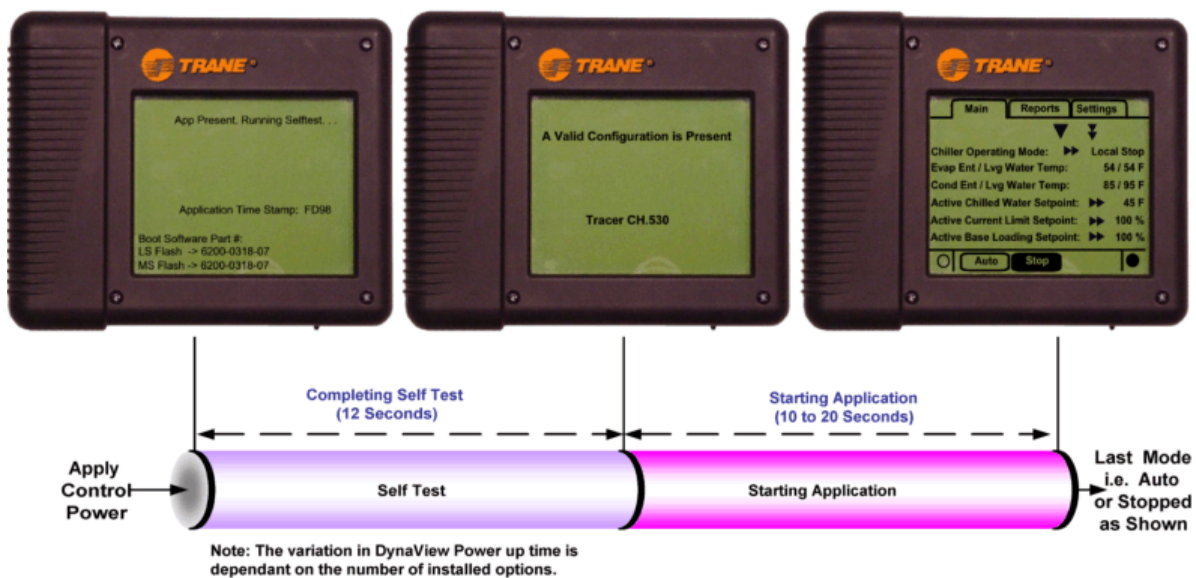

Figure 39 Power Up

### Power Up to Starting

The Power up to starting diagram shows the timing from a power up event to energizing the compressor. The shortest allowable time would be under the following conditions:

1. No motor restart inhibit
2. Evaporator and Condenser Water flowing
3. Power up Start Delay setpoint set to 0 minutes
4. Adjustable Stop to Start Timer set to 5 seconds
5. Need to cool

The above conditions would allow for a minimum power up to starting compressor time of 95 seconds.

# Unit Start-up

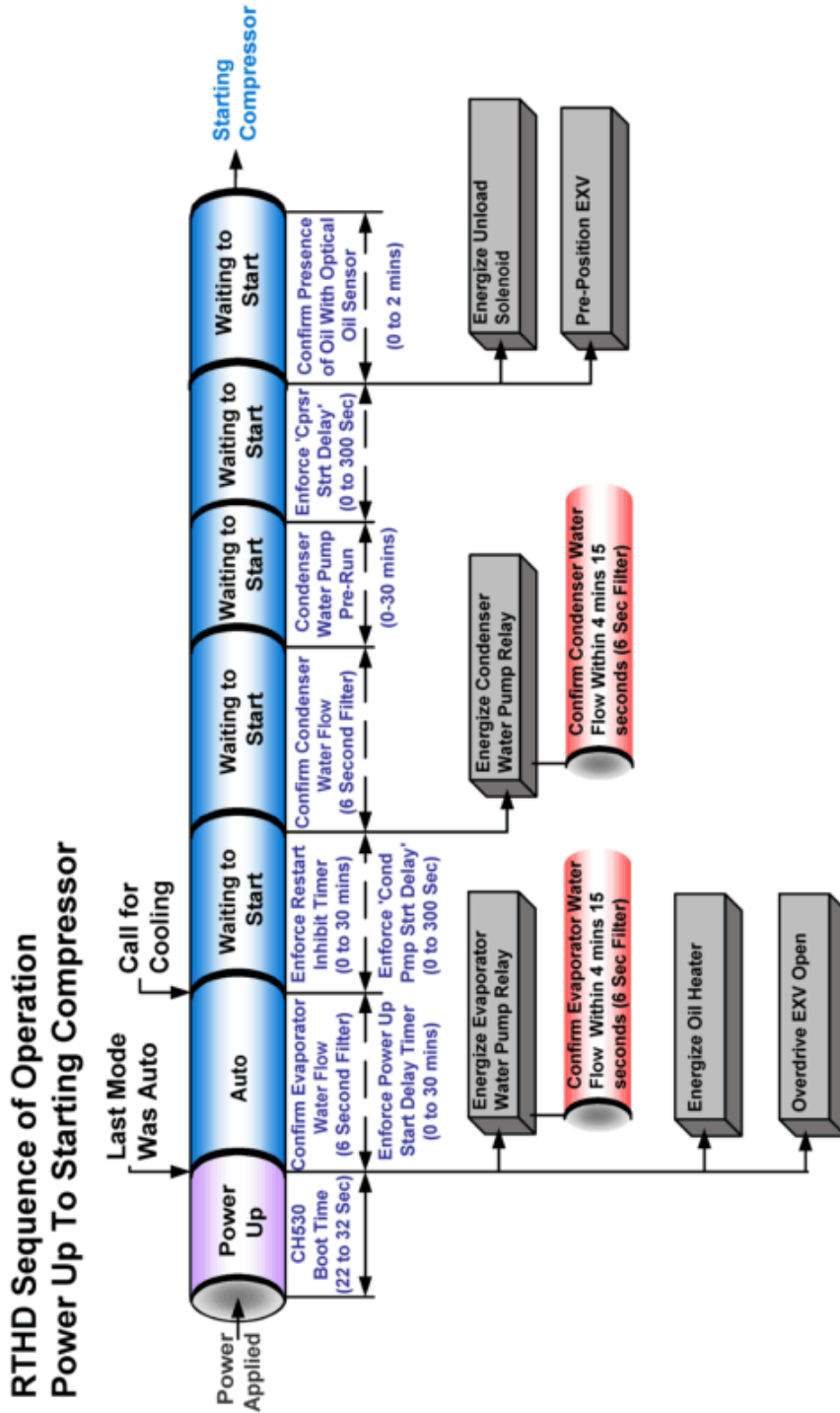

Figure 40 Power Up to Starting





## Unit Start-up

---

### **Stopped to Starting:**

The stopped to starting diagram shows the timing from a stopped mode to energizing the compressor. The shortest allowable time would be under the following conditions:

1. No motor restart inhibit
2. Evaporator and Condenser Water flowing
3. Power up Start Delay Timer has expired
4. Adjustable Stop to Start Timer has expired
5. Need to cool

The above conditions would allow the compressor to start in 60 seconds

# Unit Start-up

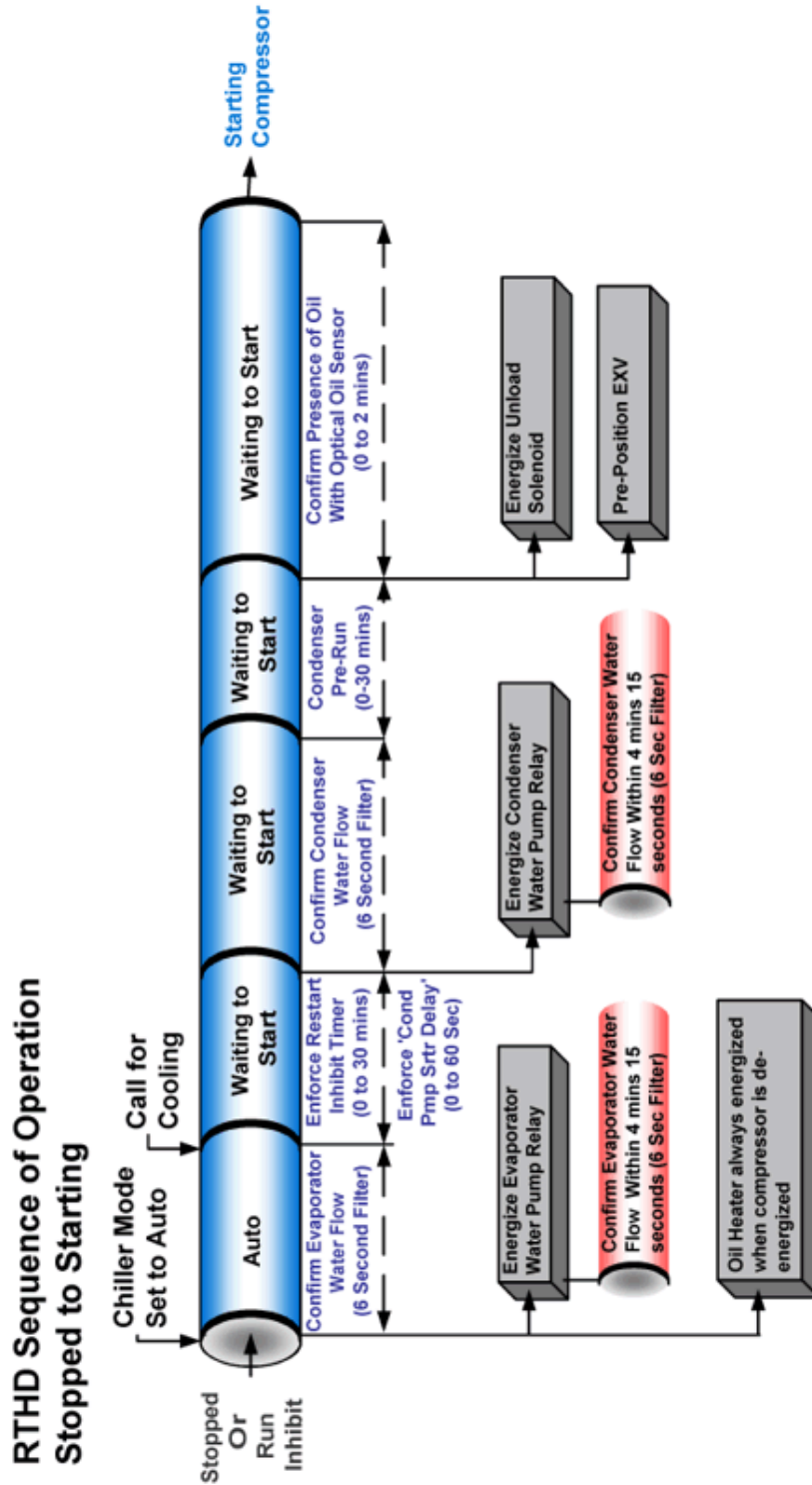

Figure 41 Stopped to Starting

# Unit Start-up

## Limit Conditions

CH530 will automatically limit certain operating parameters during startup and run modes to maintain optimum chiller performance and prevent nuisance diagnostic trips. These limit conditions are noted in [Table 25](#).

**Table 25 Limit Conditions**

<b>Running - Limited</b>	<b>The chiller, circuit, and compressor are currently running, but the operation of the chiller/compressor is being actively limited by the controls. Further information is provided by the sub-mode.</b>
Capacity Limited by High Cond Press	The circuit is experiencing condenser pressures at or near the condenser limit setting. The compressor will be unloaded to prevent exceeding the limits.
Capacity Limited by Low Evap Rfgt Temp	The circuit is experiencing saturated evaporator temperatures at or near the Low Refrigerant Temperature Cutout setting. The compressors will be unloaded to prevent tripping.
Capacity Limited by Low Liquid Level	The circuit is experiencing low refrigerant liquid levels and the EXV is at or near full open. The compressor will be unloaded to prevent tripping.
Capacity Limited by High Current	The compressor is running and its capacity is being limited by high currents. The current limit setting is 120% RLA (to avoid overcurrent trips).
Capacity Limited by Phase Unbalance	The compressor is running and its capacity is being limited by excessive phase current unbalance.

## Seasonal Unit Start-Up Procedure

1. Close all valves and re-install the drain plugs in the evaporator and condenser heads.
2. Service the auxiliary equipment according to the start-up/maintenance instructions provided by the respective equipment manufacturers.
3. Vent and fill the cooling tower, if used, as well as the condenser and piping. At this point, all air must be removed from the system (including each pass). Close the vents in the evaporator chilled water circuits.
4. Open all the valves in the evaporator chilled water circuits.
5. If the evaporator was previously drained, vent and fill the evaporator and chilled water circuit. When all air is removed from the system (including each pass), install the vent plugs in the evaporator water boxes.

## CAUTION Equipment Damage!

**Ensure that the oil sump heaters have been operating for a minimum of 24 hours before starting. Failure to do so may result in equipment damage.**

6. Check the adjustment and operation of each safety and operating control.
7. Close all disconnect switches.
8. Refer to the sequence for daily unit startup for the remainder of the seasonal startup.



# Unit Start-up

Series R Start-up Test Log					
Job Name			Job Location		
Model #		Serial #		start date:	
Sales Order #		ship date:		Job elevation (ft. above sea level)	
STARTER DATA:			START-UP ONLY		
Manufacturer			Chiller appearance at arrival:		
Type: (solid state, wye-delta)			Compressor shipping bolts removed? Y N		
Vendor ID #/Model #:			Oil separator shipping bolts removed? Y N		
Volts		Amps		Hz	
COMPRESSOR DATA:			Machine Gauge Pressure: psig/ kPag		
Model #:			Machine CH530 Pressure: psig/ kPag		
Serial #:			Complete if pressure test is required		
NAMEPLATE DATA:			Vacuum after leak test= mm		
RLA		KW		Volts	
50 60 Hz			Standing vacuum test = mm rise in hrs		
DESIGN DATA:			UNIT CHARGES		
RLA			KW		
Volts			Unit refrigerant charge: lbs/ Kg		
CURRENT TRANSFORMER			Unit Oil Charge: gal/ L		
Part Number ("X" code and 2-digit extension)			SUMMARY OF UNIT OPTIONS INSTALLED		
Primary CT's			Y N Tracer Communications Interface		
X -			Y N Options Module		
X -			Y N Outdoor Air Sensor		
X -			Y N Ice Making Control		
DESIGN CONDITIONS			Y N Other		
Evap Desig	_____ GPM L/S	_____ PSID	kPad	Ent. Water F/C _____	Leaving Water F/C _____
Evap Actual	_____ GPM L/S	_____ PSID	kPad	Ent. Water F/C _____	Leaving Water F/C _____
Cond Design	_____ GPM L/S	_____ PSID	kPad	Ent. Water F/C _____	Leaving Water F/C _____
Cond Actual	_____ GPM L/S	_____ PSID	kPad	Ent. Water F/C _____	Leaving Water F/C _____

Owner Witness Signature: \_\_\_\_\_



# Unit Start-up

<b>Installation Checklist for Model RTHD Series R</b>	
To: _____	Trane Service Company
S.O. No.: _____	Serial No: _____
Job/Project Name: _____	
<b>RECEIVING</b>	
	Verify that the unit nameplate data corresponds to the ordering information.
	Inspect the unit for shipping damage and any shortages of materials. Report any damage or shortage to the carrier.
<b>UNIT LOCATION AND MOUNTING</b>	
	Inspect the location desired for installation and verify adequate service access clearances.
	Provide drainage for evaporator and condenser water.
	Remove and discard all shipping materials (cartons, etc.)
	Install optional spring or neoprene isolators, if required. Refer to IOM for details.
	Level unit and secure it to the mounting surface.
<b>UNIT PIPING</b>	
<b>Caution:</b>	If using an acidic commercial flushing solution, construct a temporary bypass around the unit to prevent damage to the internal components of the condenser and evaporator. To avoid possible equipment damage, do not use untreated or improperly treated system water.
	Flush all unit water piping before making final connections to unit.
	Connect water piping to the evaporator and condenser.
	Install pressure gauges and shutoff valves on the water inlet and outlet to the evap. and cond.
	Install water strainers in the entering chilled water and condenser water lines.
	Install balancing valves (discretionary) and flow switches in the leaving chilled and condenser water lines.
	Install drains with shutoff valves or drain plugs on the evaporator and condenser.
	Vent the chilled water and condenser water systems at the high points of the system piping.
	Pipe relief valves outdoors in accordance to ASHRAE 15, the IOM and local code.
<b>ELECTRICAL WIRING</b>	
	<b>WARNING:</b> To prevent injury or death, disconnect electrical power source before completing wiring connections on the unit.
	Check for tight connections for the unit power supply wiring with the fused disconnect to the terminal block (or unit-mounted disconnect) in the power section of the control panel.
	Check for tight 115 volt control wiring connections to the chilled water pump and condenser water pump
	Check Interlock Wiring, including chilled water pump control, chilled water flow interlock, condenser water pump, condenser water flow interlock, external auto stop. For further details refer to the IOM or the unit wiring.
<b>Caution:</b>	Information on Interconnecting Wiring: Chilled Water Pump Interlock and External Auto/Stop must be adhered to or equipment damage may occur.
	If remote Alarm contacts, Limit Warning Contact, Outdoor Air Temperature Sensor, Emergency Stop, Head Relief Request Contact, Ice Making, External Chilled Water Setpoint, External Current Limit Setpoint, Percent Condenser Pressure output are used refer to the IOM and the unit wiring for further details.
	Control power wiring isolated in control panel/starter panel enclosure.
	Is chilled water pump control by UCP2, CH530 or Others (circle one)



## Unit Start-up

Installation Checklist for Model RTHD Series R	
PRE-START CHECK-OUT	
	Inspect all wiring connections. Connections should be clean and tight.
	Energize crankcase heaters. Heaters need to be energized 24 hours before start-up.
	Confirm that all service and isolation valves are open. Refer to RTHD-SVB01A-EN for RTHD units, RTHC-SB-1B for RTHC units and RTHB-IOM-1 for the RTHB units.
	Remove the four (3 on B Frame Compressors) compressor shipping stops (snubbers) from under the compressor. (RTHD and RTHC only)
	Remove shipping bolts from under the two oil separators (RTHD and RTHC only)
	Confirm phase-sequencing "A-B-C". Refer to the IOM for further details.
	Check all water temperature sensors for proper installation and use of heat transfer paste.
	Fill the chilled water circuit. Type of glycol _____ Percent of glycol _____ by weight
<b>Caution:</b>	To prevent equipment damage, do not use untreated or improperly treated water in the system.
	Fill the condensing water circuit.
	Close the fused disconnect switch to supply power to the chilled water pump and condenser water pump starter.
	Start the water pumps. With water pumps running, inspect all piping connections for leakage. Make any necessary repairs.
	With water pumps running, adjust water flows and check water pressure drops through the evaporator and condenser.
	Adjust the flow switches for proper operation.
	Return pumps to the automatic mode.
	Disable machine start circuit until start-up mechanic arrives (use either the external stop or emergency stop circuit)

# Unit Shutdown

## Normal Shutdown to Stopped

The Normal Shutdown diagram shows the Transition from Running through a Normal (friendly) Shutdown. The Dashed lines on the top attempt to show the final mode if you enter the stop via various inputs.

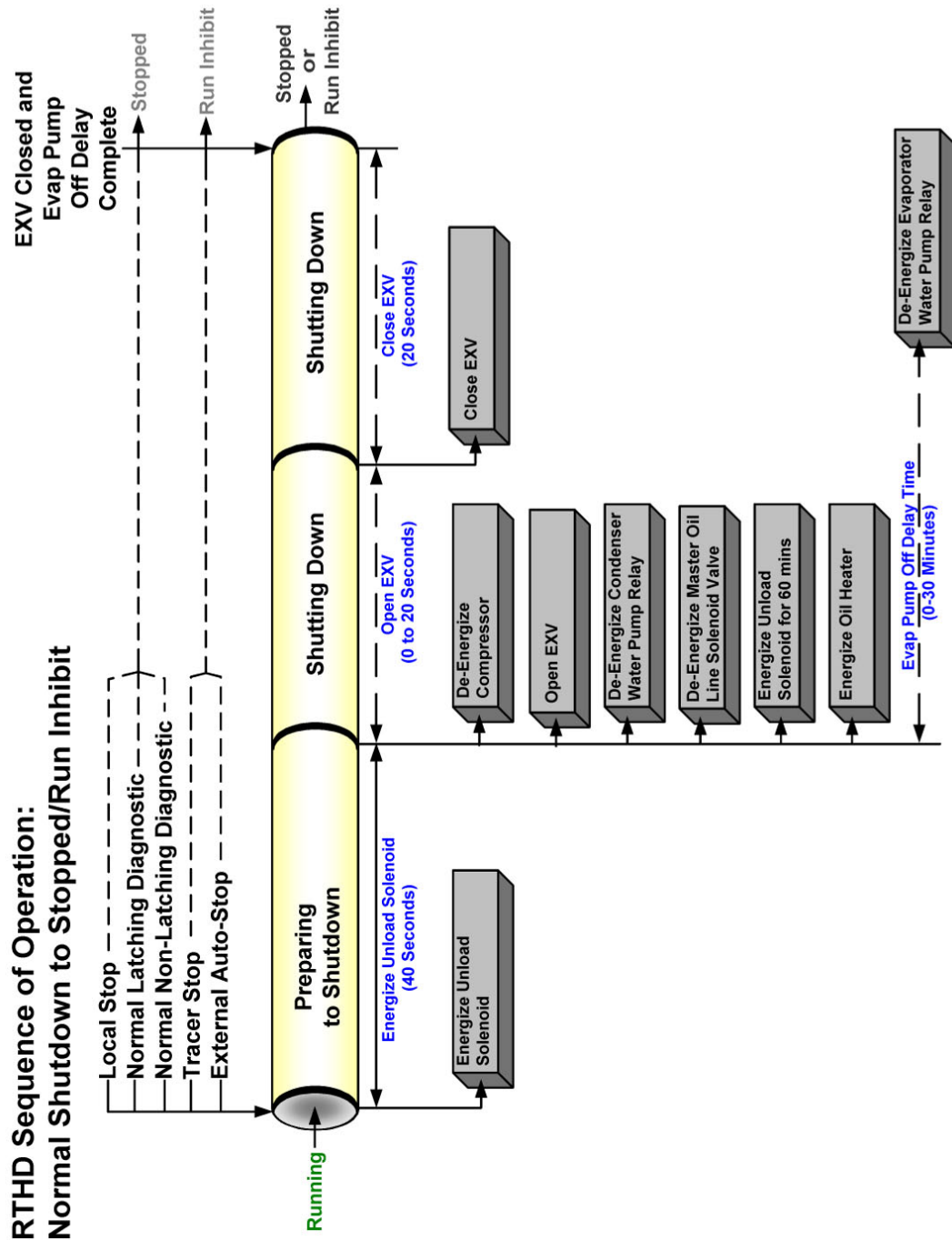

Figure 42 Normal Shutdown



# Unit Shutdown

---

## Seasonal Unit Shutdown

1. Perform the normal unit stop sequence using the <Stop> key.

*NOTE: Do not open the starter disconnect switch. This must remain closed to provide control power from the control power transformer to the oil sump heater.*

2. Verify that the chilled water and condenser water pumps are cycled off. If desired, open the disconnect switches to the pumps.
3. Drain the condenser piping and cooling tower, if desired.
4. Remove the drain and vent plugs from the condenser headers to drain the condenser.
5. Verify that the Crank Case heater is working.
6. Once the unit is secured, perform the maintenance identified in the following sections.





# Periodic Maintenance

---

## Overview

This section describes preventative maintenance procedures and intervals for the Series R unit. Use a periodic maintenance program to ensure optimal performance and efficiency of the Series R units.

An important aspect of the chiller maintenance program is the regular completion of the "Series R Operating Log"; an example of this log is provided in this manual. When filled out properly the completed logs can be reviewed to identify any developing trends in the chiller's operating conditions.

For example, if the machine operator notices a gradual increase in condensing pressure during a month's time, he can systematically check for and then correct, the possible cause(s) of this condition (e.g., fouled condenser tubes, non-condensables in the system).

## Weekly Maintenance and Checks

After the unit has operated for approximately 30 minutes and the system has stabilized, check the operating conditions and complete the procedures below:

- Log the chiller.
- Check evaporator and condenser pressures with gauges and compare to the reading on the Clear Language Display. Pressure readings should fall within the following ranges specified in the Operating Conditions.

*NOTE: Optimum condenser pressure is dependent on condenser water temperature, and should equal the saturation pressure of the refrigerant at a temperature 2 to 5°F above that of leaving condenser water at full load.*

## Monthly Maintenance and Checks

- Review operating log.
- Clean all water strainers in both the chilled and condensing water piping systems.
- Measure the oil filter pressure drop. Replace oil filter if required. Refer to "Service Procedures".
- Measure and log the subcooling and superheat.
- If operating conditions indicate a refrigerant shortage, leak check the unit; confirm using soap bubbles.
- Repair all leaks.
- Trim refrigerant charge until the unit operates in the conditions listed in the note below.

*NOTE: ARI conditions are: condenser water: 85°F and 3 GPM per ton and evaporator water: 54-44°F.*

# Periodic Maintenance

**Table 26 Operating Conditions at Full Load**

Description	Condition
Evaporator pressure	40-55 psig
Condensing pressure	85-120 psig
Discharge superheat	17°F
Subcooling	5-10°F
EXV percent open	40-50% open in Auto mode

All conditions stated above are based on the unit running fully loaded, running at ARI conditions.

- If full load conditions can not be met. Refer to note below to trim the refrigerant charge

*NOTE: Conditions at minimum must be: entering condenser water: 85°F and entering evaporator water: 55°F*

**Table 27 Operating Conditions at Minimum Load**

Description	Condition
Evaporator approach	*less than 7°F (non-glycol applications)
Condensing approach	*less than 7°F
Subcooling	2-3°F
EXV percent open	10-20 % open

\*  $\cong$  1.0°F for new unit.

## Annual Maintenance

Shut down the chiller once each year to check the following:

### **⚠ WARNING** **Hazardous Voltage!**

**Disconnect all electric power, including remote disconnects and discharge all motor start/run capacitors before servicing. Follow proper lockout/tagout procedures to ensure the power cannot be inadvertently energized. Verify with an appropriate voltmeter that all capacitors have discharged. Failure to disconnect power and discharge capacitors before servicing could result in death or serious injury.**



## Periodic Maintenance

---

- Perform all weekly and monthly maintenance procedures.
- Check the refrigerant charge and oil level. Refer to "Maintenance Procedures". Routine oil changing is not necessary on a hermetic system.
- Have a qualified laboratory perform an oil analysis to determine system moisture content and acid level.

*NOTE: IMPORTANT: Due to the hygroscopic properties of the POE oil, all oil must be stored in metal containers. The oil will absorb water if stored in a plastic container*

- Check the pressure drop across the oil filter. Refer to "Maintenance Procedures".
- Contact a qualified service organization to leak check the chiller, to inspect safety controls, and inspect electrical components for deficiencies.
- Inspect all piping components for leakage and/or damage. Clean out any inline strainers.
- Clean and repaint any areas that show signs of corrosion.
- Test vent piping of all relief valves for presence of refrigerant to detect improperly sealed relief valves. Replace any leaking relief valve.
- Inspect the condenser tubes for fouling; clean if necessary. Refer to "Maintenance Procedures".
- Check to make sure that the crank case heater is working.

### Scheduling Other Maintenance

- Use a nondestructive tube test to inspect the condenser and evaporator tubes at 3-year intervals.

*NOTE: It may be desirable to perform tube tests on these components at more frequent intervals, depending upon chiller application. This is especially true of critical process equipment.*

- Depending on chiller duty, contact a qualified service organization to determine when to conduct a complete examination of the unit to determine the condition of the compressor and internal components.

### Operating Log

A sample of several operating logs and checklists have been included.



# Periodic Maintenance

Chiller Log			
Main Tab	Run Time		
	15 min	30 min	1 hr
Chiller Mode			
Evap Ent/Lvg Water Temp			
Cond Ent/Lvg Water Temp			
Active Chilled Water Setpoint (F)			
Average Line Current (%RLA)			
Active Current Limit Setpoint (%RLA)			
Software Type			
Software Version			
Reports Tab			
Evaporator			
Evap Entering Water Temperature (F)			
Evap Leaving Water Temperature (F)			
Evap Sat Rfgt Temp (F)			
Evap Rfgt Pressure (psia)			
Evap Approach Temp (F)			
Evap Water Flow Switch Status			
Expansion Valve Position (%)			
Expansion Valve Position Steps			
Evap Rfgt Liquid Level (in)			
Condenser			
Cond Entering Water Temperature (F)			
Cond Leaving Water Temperature (F)			
Cond Sat Rfgt Temp (F)			
Cond Rfgt Pressure (psia)			
Cond Approach Temp (F)			
Cond Water Flow Switch Status			
Cond Head Pressure Ctrl Command (%)			
Compressor			
Compressor Starts			
Compressor Run Time			
System Rfgt Diff Pressure (psid)			
Oil Pressure (psia)			
Compressor rfgt Discharge Temp (F)			
Discharge Superheat (F)			
% RLA L1 L2 L3 (%)			
Amps L1 L2 L3 (Amps)			
Volts AB BC CA			



# Periodic Maintenance

---

<b>Settings</b>	
<b>Settings Tab</b>	
<b>Chiller</b>	
Front Panel Chilled Water Setpt (F)	
Front Panel Current Limit Setpt (RLA)	
Differential to Start (F)	
Differential to Stop (F)	
Setpoint Source	
<b>Feature Settings</b>	
Chilled Water Reset	
Return Reset Ratio	
Return Start Reset	
Return Maximum Reset	
Outdoor Reset Ratio	
Outdoor Start Reset	
Outdoor Maximum Reset	
<b>Mode Overrides</b>	
Evap Water Pump	
Cond Water Pump	
Expansion Valve Control	
Slide Valve Control	
Service Pumpdown	
<b>Display Settings</b>	
Date Format	
Date	
Time Format	
Time of Day	
Keypad/Display Lockout	
Display Units	
Pressure Units	
Language Selection	



# Periodic Maintenance

---

# Maintenance Procedures

---

## Cleaning the Condenser

### CAUTION

#### Proper Water Treatment!

**The use of untreated or improperly treated water in a RTHD may result in scaling, erosion, corrosion, algae or slime. It is recommended that the services of a qualified water treatment specialist be engaged to determine what water treatment, if any, is required. The Trane Company assumes no responsibility for equipment failures which result from untreated or improperly treated water, saline or brackish water.**

Condenser tube fouling is suspect when the “approach” temperature (i.e., the difference between the refrigerant condensing temperature and the leaving condenser water temperature) is higher than predicted.

Standard water applications will operate with less than a 10°F approach. If the approach exceeds 10°F cleaning the condenser tubes is recommended.

*NOTE: Glycol in the water system typically doubles the standard approach.*

If the annual condenser tube inspection indicates that the tubes are fouled, 2 cleaning methods can be used to rid the tubes of contaminants. The methods are:

#### Mechanical Cleaning Procedure

Mechanical tube cleaning this method is used to remove sludge and loose material from smooth-bore condenser tubes.

### ⚠ WARNING

#### Heavy Objects!

**Each of the individual cables (chains or slings) used to lift the waterbox must be capable of supporting the entire weight of the waterbox. The cables (chains or slings) must be rated for overhead lifting applications with an acceptable working load limit. Failure to properly lift waterbox could result in death or serious injury.**

#### Eyebolts!

**The proper use and ratings for eyebolts can be found in ANSI/ASME standard B18.15. Maximum load rating for eyebolts are based on a straight vertical lift in a gradually increasing manner. Angular lifts will significantly lower maximum loads and should be avoided whenever possible. Loads should always be applied to eyebolts in the plane of the eye, not at some angle to this plane. Failure to properly lift waterbox could result in death or serious injury.**

## Maintenance Procedures

---

Review mechanical room limitations and determine the safest method or methods of rigging and lifting the waterboxes.

1. Determine the size of chiller being serviced. Refer to Trane Nameplate located on chiller control panel.
2. Select the proper lift connection device from [Table 30](#). The rated lifting capacity of the selected lift connection device must meet or exceed the published weight of the waterbox.
3. Insure the lift connection device has the correct connection for the waterbox. Example: thread type (course/fine, English/metric). Bolt diameter (English/metric).
4. Properly connect the lift connection device to the waterbox. Refer to [Figure 43](#). Insure lift connection device is securely fastened.

Install hoist ring on to the lifting connection on the waterbox. Torque to 28 ft-lbs (37 Nm).

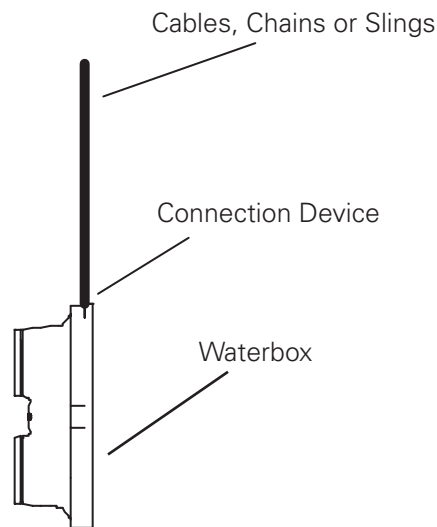

**Figure 43 Water Box Lifting**

5. Disconnect water pipes, if connected.
6. Remove waterbox bolts
7. Lift the waterbox away from the shell.



# Maintenance Procedures

## ⚠ WARNING OVERHEAD HAZARD!

**Never stand below or in close proximity to heavy objects while they are suspended from, or being lifted by, a lifting device. Failure to follow these instructions could result in death or serious injuries.**

8. Store waterbox in a safe and secure location and position.  
**Do not leave waterbox suspended from lifting device.**
9. Work a round nylon or brass bristled brush (attached to a rod) in and out of each of the condenser water tubes to loosen the sludge.
10. Thoroughly flush the condenser water tubes with clean water.  
(To clean internally enhanced tubes, use a bi-directional brush or consult a qualified service organization for recommendations.)

### Reassembly

Once service is complete the waterbox should be reinstalled on the shell following all previous procedures in reverse. Use new o-rings or gaskets on all joints after thoroughly cleaning each joint.

1. Torque waterbox bolts.  
Torque bolts in a star pattern. Refer to [Table 28](#) for torque values.

**Table 28 RTHD Torque**

Evaporator	Condenser
65 ft-lbs (88 Nm)	65 ft-lbs (88 Nm)

### Waterbox Weights

**Table 29 RTHD Waterbox Weights**

Waterbox	Size	Number of Water Passes	Standard Grooved Pipe Waterbox		Marine Style Waterbox	
			Weight Kg (lbs)	Lifting Connection	Weight Kg (lbs)	Lifting Connection
Evaporator	G <sup>1</sup>	4	164 (361)	M12x1.75	NA	NA
Evaporator	G <sup>1</sup>	3	208 (458)	M12x1.75	NA	NA

<sup>1</sup> Digit 14 of the model number

<sup>2</sup> Digit 21 of the model number

<sup>3</sup>Removable cover has a weight of 136 Kg (300 lbs) Lifting Connection M12x1.75 tapped hole



# Maintenance Procedures

**Table 29** RTHD Waterbox Weights

Waterbox	Size	Number of Water Passes	Standard Grooved Pipe Waterbox		Marine Style Waterbox	
			Weight Kg (lbs)	Lifting Connection	Weight Kg (lbs)	Lifting Connection
Evaporator	F <sup>1</sup>	3	107 (235)	M12x1.75	NA	NA
Evaporator	F <sup>1</sup>	2	107 (235)	M12x1.75	NA	NA
Evaporator	D/E <sup>1</sup>	3	91 (201)	M12x1.75	NA	NA
Evaporator	D/E <sup>1</sup>	2	110 (243)	M12x1.75	NA	NA
Evaporator	B/C <sup>1</sup>	3	76 (167)	M12x1.75	NA	NA
Evaporator	B/C <sup>1</sup>	2	91 (201)	M12x1.75	NA	NA
Evaporator	B/C <sup>1</sup>	2	73 (160)	M12x1.75	NA	NA
Condenser	G <sup>2</sup>	2	102 (226)	M12x1.75	297 (655)	Lifting Lug <sup>3</sup>
Condenser	E/F <sup>2</sup>	2	66 (146)	M12x1.75	239 (526)	Lifting Lug <sup>3</sup>
Condenser	B/D <sup>2</sup>	2	53 (116)	M12x1.75	187 (412)	Lifting Lug <sup>3</sup>

<sup>1</sup> Digit 14 of the model number

<sup>2</sup> Digit 21 of the model number

<sup>3</sup>Removable cover has a weight of 136 Kg (300 lbs) Lifting Connection M12x1.75 tapped hole

### Parts Ordering Information

Use the Table 30, "Connection Devices," on page 136 for part ordering information.

**Table 30** Connection Devices

Unit	Product	Part Number
RTHD	Safety Hoist Ring M12x1.75	RNG01886

Obtain the required parts from your local Trane Parts Center.

### Chemical Cleaning Procedure

- Scale deposits are best removed by chemical means. Consult a qualified water treatment specialist (i.e., one that knows the local water supply chemical/mineral content) for a recommended cleaning solution suitable for the job. (A standard condenser water circuit is composed solely of copper, cast iron and steel.) Improper chemical cleaning can damage tube walls.

# Maintenance Procedures

All of the materials used in the external circulation system, the quantity of the solution, the duration of the cleaning period, and any required safety precautions should be approved by the company furnishing the materials or performing the cleaning.

*NOTE: Chemical tube cleaning should always be followed by mechanical tube cleaning.*

## Cleaning the Evaporator

Since the evaporator is typically part of a closed circuit, it does not accumulate appreciable amounts of scale or sludge. However, if cleaning is deemed necessary, use the same cleaning methods described for the condenser tubes.

## Compressor Oil

### CAUTION

### Equipment Damage!

**To prevent oil sump heater burnout, open the unit main power disconnect switch before removing oil from the compressor.**

Trane Polyolester Oil is the approved oil for the RTHD units. Polyolester oil is extremely hygroscopic meaning it readily attracts moisture. The oil can not be stored in plastic containers due to the hygroscopic properties. As with mineral oil, if water is in the system it will react with the oil to form acids. Use Table 31 to determine the acceptability of the oil.

**Table 31 POE Oil Properties**

Description	Acceptable Levels
Moisture content	less than 300 ppm
Acid Level	less than 0.5 TAN (mg KOH/g)
Mineral oil used in the RTHA and RTHB units had different acceptable levels (< 50 ppm of moisture and < 0.05 mg KOH/g)	

*NOTE:* Note: Use an oil transfer pump to change the oil regardless of chiller pressure.

## Oil Sump Level Check

Running the chiller at minimum load is the best for the quickest return of oil to the separator and sump. The machine still needs to sit for approximately 30 minutes before the level is taken. At minimum load, the discharge superheat should be highest. The more heat in the oil as it lays in the sump, the more refrigerant will boil off in the sump and leave more concentrated oil.

The oil level in the oil sump can be measured to give an indication of the system oil charge. Follow the procedures below to measure the level.

1. Run the unit fully unloaded for approximately 20 minutes.
2. Cycle the compressor off line.

# Maintenance Procedures

---

## CAUTION Oil Loss!

Never operate the compressor with the sightglass service valves opened. Severe oil loss will occur. Close the valves after checking the oil level. The sump is above the condenser and it is possible to drain the oil.

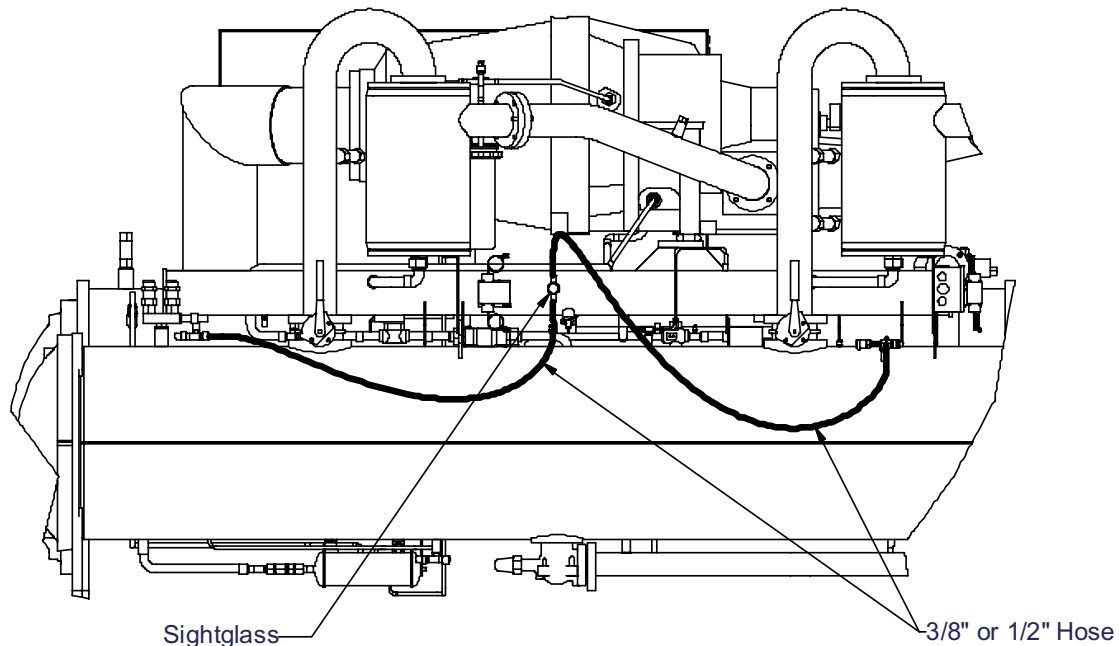

**Figure 44** Determining Oil Level in Sump

3. Attach a 3/8" or 1/2" hose with a sightglass in the middle to the oil sump drain valve and the condenser service valve at the top of the condenser. Using high pressure rated clear hose with appropriate fittings can help speed up the process.
4. After the unit is off line for 30 minutes, move the sightglass along the side of the oil sump.
5. The level should be between 2" and 5" from the bottom of the oil sump. If the level appears to be above 8", the oil sump is completely full. Most likely more oil resides in the rest of the system and some oil needs to be removed until the level falls between 2" and 5" in the oil sump.

## Maintenance Procedures

---

6. If the level is below 2", there is not enough oil in the sump. This can occur from not enough oil in the system or more likely, oil migration to the evaporator. Oil migration can occur from a low refrigerant charge, gas pump malfunction, etc.

*NOTE: If the oil is logged in the evaporator confirm the operation of the gas pump. If the gas pump is not functioning properly all oil will be logged in the evaporator.*

7. After the level is determined, close the service valves and remove the hose/sightglass assembly.

### Removing Compressor Oil

The oil in the compressor oil sump is under a constant positive pressure at ambient temperature. To remove oil, open the service valve located on the bottom of the oil sump and drain the oil into a suitable container using the procedure outlined below:

### CAUTION

#### POE Oil!

**Due to the hygroscopic properties of the POE oil, all oil must be stored in metal containers. The oil will absorb water if stored in a plastic container.**

Oil should not be removed until the refrigerant is isolated or removed.

8. Connect a line to the oil sump drain valve.
9. Open the valve and allow the desired amount of oil to flow into the container and close the charging valve.
10. Measure the exact amount of oil removed from the unit.

### Oil Charging Procedure

It is critical to fill the oil lines feeding the compressor when charging a system with oil. The diagnostic "Loss of oil at the compressor stopped" will be generated if the oil lines are not full on start-up.

To properly charge the system with oil, follow the steps below:

1. Locate the 1/4" schrader valve between the ball valve and oil filter (or the ball valve and oil cooler, if so equipped).
2. Loosely connect oil pump to schrader valve called out in step 1.
3. Operate oil charging pump until oil appears at the charging valve connection; then tighten the connection.

*NOTE: Note: To keep air from entering the oil, the charging valve connection must be air-tight.*

4. Close the ball valve just upstream of the schrader valve connected to the oil pump. This will allow the oil to travel through the oil lines to the compressor first rather than directly to the oil sump.
5. Energize the master oil solenoid.

## Maintenance Procedures

---

6. This will allow the oil to travel from the schrader to the compressor. It takes approximately 2 gallons of oil to fill the lines.
7. After charging the first 2 gallons, de-energize the master solenoid.
8. Open the ball valve just upstream of the schrader connected to the oil pump. This will allow the remainder of the charge to flow to the oil sump.
9. Monitor the “Oil Loss Level Sensor Status in TechView under the Status view. This display shows whether the optical sensor is seeing oil (wet) or if it is not (dry).

*NOTE: The remainder of the oil charge can be charged into the 1/4” service valve located at the bottom of the sump if a larger connection is preferred.*

### Replacing the Main Oil Filter (Hot Filter)

The filter element should be changed if the oil flow is sufficiently obstructed. Two things can happen: first, the chiller may shut down on a “Low Oil Flow” diagnostic, or secondly, the compressor may shut down on a “Loss of Oil at Compressor (Running) diagnostic. If either of these diagnostics occurs, it is possible the oil filter needs replacement. The oil filter is not usually the cause of a Loss of oil at Compressor diagnostic.

Specifically, the filter must be changed if the pressure drop between the two service valves in the lubrication circuit exceeds the maximum level as given in Figure 45. This chart shows the relationship between the pressure drop measured in the lubrication circuit as compared with operating pressure differential of the chiller (as measured by pressures in the condenser and evaporator).

Normal pressure drops between the service valves of the lubrication circuit are shown by the lower curve. The upper curve represents the maximum allowable pressure drop and indicates when the oil filter must be changed. Pressure drops that lie between the lower and upper curves are considered acceptable.

For a chiller equipped with an oil cooler, add 5 psid to the values shown in Figure 45. For example, if the system pressure differential was 80 psid, then the clean filter pressure drop would be approximately 15 psid (up from 10 psid). For a chiller with an oil cooler and operating with a dirty oil filter, the maximum allowable pressure drop would be 28 psid (up from 23 psid).

Under normal operating conditions the element should be replaced after the first year of operation and then as needed thereafter.

Refer to Table 4 - Table 6 and Unit nameplate for Oil charge information.

1. Isolate the oil filter by closing the two ball valves located before and after the filter.
2. Relieve the pressure from the hydraulic line through the 1/4” schrader valve located between the ball valve and the oil filter (or the ball valve and oil cooler, if so equipped).
3. Use a strap wrench to break loose the nut that secures the oil filter element to the filter manifold.
4. Turn the nut clockwise until the filter element detaches from the manifold.
5. Remove the filter element and measure the exact amount of oil contained in the filter bowl and element.

# Maintenance Procedures

6. Place the cartridge in the nut after filling the bowl with the proper amount of refrigerant oil (see Step 5). Turn the new nut assembly counterclockwise and tighten securely.
7. Connect manifold gauge set at oil charging valve and evacuate the filter to 500 microns.
8. Charge the oil line back with the amount of oil removed. Open the isolation valves to the oil supply system.

## Replacing the Gas Pump Oil Filter

The filter element in the gas pump circuit may need to be changed if the gas pump is unable to return the oil to the compressor.

An evaporator logged with oil will have a high liquid level when referring to the liquid level sensor, low suction pressures, and higher than normal approach on the evaporator.

Refer to Figure 45 to determine if the pressure drop across the filter is above the normal range at full load conditions. Once the oil is logged in the evaporator, it may be necessary to manually move the oil from the evaporator to the oil sump to avoid losses in the main oil lines.

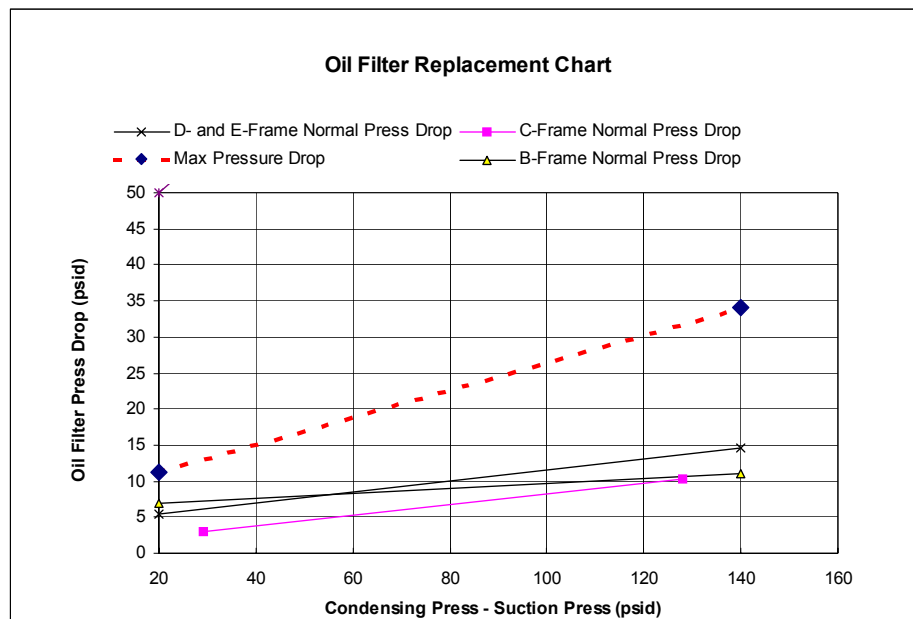

Figure 45 Oil Filter Replacement Chart (E,D, C and B Frame Compressors)

## Refrigerant Charge

If a low refrigerant charge is suspected, first determine the cause of lost refrigerant. Once the problem is repaired follow the procedures below for evacuating and charging the unit.

### Evacuation and Dehydration

1. Disconnect ALL power before/during evacuation.



## Maintenance Procedures

---

2. Connect the vacuum pump to the 5/8" flare connection on the bottom of the evaporator and/or condenser.
3. To remove all of the moisture from the system and to insure a leak free unit, pull the system down below 500 microns.
4. After the unit is evacuated, perform a standing rise test for at least an hour. The pressure should not rise more than 150 microns. If the pressure rises more than 150 microns, either a leak is present or moisture is still in the system.

*NOTE: If oil is in the system, this test is more difficult. The oil is aromatic and will give off vapors that will raise the pressure of the system.*

### Refrigerant Charging

Once the system is deemed leak and moisture free, use the 5/8" flare connections at the bottom of the evaporator and condenser to add refrigerant charge.

Refer to Table 4 - Table 6 and Unit nameplate for Refrigerant charge information.

### Freeze Protection

For unit operation in a low temperature environment, adequate protection measures must be taken against freezing. Adjusted settings and recommended ethylene glycol solution strengths are contained in Table 32 as follows:



**Table 32 Low Refrigerant Temperature, Ethylene Glycol, and Freeze Protection Settings**

Chilled Water Setpt (°F) <sup>1</sup>	Leaving Wtr Temp Cutout (°F)	DDE, EDE, CBC*			DFF, EFF, CDE, BCD, BBB, CFF*			DGG, EGG, CEF*		
		Low Rfght Temp Cutout (°F)	Rec % Ethylene Glycol	Solution Freeze Point (°F)	Low Rfght Temp Cutout (°F)	Rec % Ethylene Glycol	Solution Freeze Point (°F)	Low Rfght Temp Cutout (°F)	Rec % Ethylene Glycol	Solution Freeze Point (°F)
40	34	28.6	0	32.0	28.6	0	32.0	28.6	0	32.0
39	33	27.2	2	30.6	27.6	1	31.3	27.9	0	32.0
38	32	25.7	4	29.1	26.5	3	30.1	27.2	2	31.1
37	31	24.2	6	27.6	25.4	5	28.9	26.5	3	30.2
36	30	22.7	8	26.1	24.2	6	27.7	25.7	4	29.3
35	29	21.1	11	24.5	23.0	8	26.4	24.9	6	28.3
34	28	20.2	12	23.6	22.1	10	25.5	24.0	7	27.4
33	27	19.2	13	22.6	21.1	11	24.5	23.0	8	26.4
32	26	18.1	15	21.5	20.1	12	23.5	22.0	10	25.4
31	25	17.0	16	20.4	18.8	14	22.2	20.6	12	24.0
30	24	15.9	17	19.3	17.6	15	21.0	19.3	13	22.7
29	23	14.8	18	18.2	16.6	16	20.0	18.4	14	21.8
28	22	13.6	20	17.0	15.5	17	18.9	17.4	15	20.8
27	21	12.4	21	15.8	14.4	18	17.8	16.4	16	19.8
26	20	11.2	22	14.6	13.3	20	16.7	15.4	17	18.8
25	19	9.9	23	13.3	12.1	21	15.5	14.3	19	17.7
24	18	8.6	24	12.0	10.9	22	14.3	13.2	20	16.6
23	17	7.3	25	10.7	9.7	23	13.1	12.1	21	15.5
22	16	5.9	26	9.3	8.4	24	11.8	10.9	22	14.3

**Table 32 Low Refrigerant Temperature, Ethylene Glycol, and Freeze Protection Settings**

Chilled Water Setpt (°F) <sup>1</sup>	DDE, EDE, CBC*			DFF, EFF, CDE, BCD, BBB, CFF*			DGG, EGG, CEF*			
	Leaving Wtr Temp Cutout (°F)	Low Rfght Temp Cutout (°F)	Rec % Ethylene Glycol	Solution Freeze Point (°F)	Low Rfght Temp Cutout (°F)	Rec % Ethylene Glycol	Solution Freeze Point (°F)	Low Rfght Temp Cutout (°F)	Rec % Ethylene Glycol	Solution Freeze Point (°F)
21	15	4.5	27	7.9	7.1	25	10.5	9.7	23	13.1
20	14	3.1	28	6.5	5.8	26	9.2	8.5	24	11.9
19	13	1.6	30	5.0	4.4	27	7.8	7.3	25	10.7
18	12	0.1	31	3.5	3.1	29	6.5	6.0	27	9.4
17	11	-1.4	32	2.0	1.6	30	5.0	4.7	28	8.1
16	10	-2.9	33	0.5	0.2	31	3.6	3.3	29	6.7
15	9	-4.5	33	-1.1	-1.3	32	2.1	2.0	30	5.4
14	8	N/A	34	-2.8	-2.8	33	0.6	0.6	31	4.0
13	7	N/A	35	-4.4	-4.3	34	-0.9	-0.8	32	2.6
12	6	N/A	36	-6.1	N/A	34	-2.5	-2.3	33	1.1
11	5	N/A	37	-7.8	N/A	35	-4.1	-3.8	34	-0.4
10	4	N/A	38	-9.6	N/A	36	-5.7	-5.3	34	-1.9

Notes: \* Refer to unit Model No. digits 6, 14, 21

1) Column "Chilled water Setpoint" becomes "Actual Leaving Solution Temperature" for Ice Making.

N/A means chiller is not to be applied at leaving evaporator water temperatures, which result in the LRTC setting below those shown in the table.

**Example For Ice Making:**

Chilled Water Setpoint (std. comfort cooling) = 45 F

Full Load Delta T (across evaporator) = 6 F

Ice Termination Setpoint (entering water temp.) = 26F

Actual Leaving Solution Temperature = 26 - 6 = 20 F

# Diagnostics

The following diagnostic Table contains all the diagnostics possible. Not all data is available unless TechView is installed.

**Hex Code:** 3 digit hexadecimal code used on all past products to uniquely identify diagnostics. Refer to the database \\SRV-et-data\ucp3\service-tool\databases\servicetool.mdb

**Diagnostic Name and Source:** Name of diagnostic and its source. Note that this is the exact text used in the User Interface and/or Service Tool displays.

**Severity:** Defines the severity of the above effect. Immediate means immediate shutdown of the effected portion, Normal means normal or friendly shutdown of the effected portion, Special Mode means a special mode of operation (limp along) is invoked, but without shutdown, and Info means an Informational Note or Warning is generated.

**Persistence:** Defines whether or not the diagnostic and its effects are to be manually reset (Latched), or can be either manually or automatically reset (Nonlatched).

**Criteria:** Quantitatively defines the criteria used in generating the diagnostic and, if nonlatching, the criteria for auto reset. If more explanation is necessary a hot link to the Functional Specification is used.

**Reset Level:** Defines the lowest level of manual diagnostic reset command which can clear the diagnostic. The manual diagnostic reset levels in order of priority are: Local and Remote. A diagnostic that has a reset level of Local, can only be reset by a local diagnostic reset command, but not by the lower priority remote Reset command whereas a diagnostic listed as Remote reset can be reset by either.

**Table 33 Diagnostic List**

Hex Code	Diagnostic Name and Source	Severity	Persistence	Criteria	Reset Level
3D8	At Speed Input Opened	Immediate	Latch	The "At Speed" input was found to be opened with the compressor motor running after successfully obtaining an at speed and bypassed condition. This is active for solid state starters only	Local
3D6	At Speed Input Shorted	Immediate	Latch	The "At Speed" input is shorted before the compressor was started. This is active for only solid state starters.	Local
398	BAS Communication Lost	Special		The BAS was setup as "installed" at the MP and the Comm 3 lld lost communications with the BAS for 15 contiguous minutes after it had been established. Refer to Section on Setpoint Arbitration to determine how setpoints and operating modes may be effected by the comm loss. The chiller follows the value of the Tracer Default Run Command which can be previously written by Tracer and stored nonvolatily by the MP (either use local or shutdown).	Remote

# Diagnostics

**Table 33 Diagnostic List**

<b>Hex Code</b>	<b>Diagnostic Name and Source</b>	<b>Severity</b>	<b>Persistence</b>	<b>Criteria</b>	<b>Reset Level</b>
390	BAS Failed to Establish Communication	Special		The BAS was setup as "installed" and the BAS did not communicate with the MP within 15 minutes after power-up. Refer to Section on Setpoint Arbitration to determine how setpoints and operating modes may be effected. Note: The original requirement for this was 2 minutes, but was implemented at 15 minutes for RTAC.	Remote
2E6	Check Clock	Info	Latch	The real time clock had detected loss of its oscillator at some time in the past. Check / replace battery? This diagnostic can be effectively cleared only by writing a new value to the chiller's time clock using the TechView or DynaView's "set chiller time" functions.	Remote
8A	Chilled Water Flow (Entering Water Temp)	Info	NonLatch	The entering evaporator water temp fell below the leaving evaporator water temp. by more than 2°F for 100 °F-sec. For falling film evaporators this diagnostic cannot reliably indicate loss of flow, but can warn of improper flow direction through the evaporator, misbound temperature sensors, or other system problems	Remote
5F8	Comm Loss: Chilled Water Pump Starter	Info	Latch	Continual loss of communication between the MP and the Functional ID has occurred for a 30 second period.	Remote
5EF	Comm Loss: Chilled Water Flow Switch	Immediate	Latch	Continual loss of communication between the MP and the Functional ID has occurred for a 30 second period.	Remote
6B6	Comm Loss: Compressor % RLA Output	Info	Latch	Continual loss of communication between the MP and the Functional ID has occurred for a 30 second period.	Remote
6B6	Comm Loss: Compressor Discharge Temperature	Immediate	Latch	Continual loss of communication between the MP and the Functional ID has occurred for a 30 second period.	Remote
6B6	Comm Loss: Cond Head Press Cntrl Output	Info	Latch	Continual loss of communication between the MP and the Functional ID has occurred for a 30 second period.	Remote
6B6	Comm Loss: Condenser Entering Water Temperature	Info and Special Action	Latch	Continual loss of communication between the MP and the Functional ID has occurred for a 30 second period. If chiller running, and condenser water regulating valve option installed, force valve to 100% flow.	Remote
6B6	Comm Loss: Condenser Leaving Water Temperature	Info	Latch	Continual loss of communication between the MP and the Functional ID has occurred for a 30 second period.	Remote
5F2	Comm Loss: Condenser Rfgr Pressure	Normal	Latch	Continual loss of communication between the MP and the Functional ID has occurred for a 30 second period.	Remote

# Diagnostics

**Table 33 Diagnostic List**

<b>Hex Code</b>	<b>Diagnostic Name and Source</b>	<b>Severity</b>	<b>Persistence</b>	<b>Criteria</b>	<b>Reset Level</b>
6B6	Comm Loss: Condenser Rfgt Pressure Output	Info	Latch	Continual loss of communication between the MP and the Functional ID has occurred for a 30 second period.	Remote
5F9	Comm Loss: Condenser Water Pump Starter	Info	Latch	Continual loss of communication between the MP and the Functional ID has occurred for a 30 second period.	Remote
694	Comm Loss: Electronic Expansion Valve, Actuator 1	Normal	Latch	Continual loss of communication between the MP and the Functional ID has occurred for a 30 second period.	Remote
695	Comm Loss: Electronic Expansion Valve, Actuator 2	Normal	Latch	Continual loss of communication between the MP and the Functional ID has occurred for a 30 second period.	Remote
5DE	Comm Loss: Emergency Stop	Normal	Latch	Continual loss of communication between the MP and the Functional ID has occurred for a 30 second period.	Remote
5E4	Comm Loss: Evaporator Entering Water Temperature	Info and Special Action	Latch	Continual loss of communication between the MP and the Functional ID has occurred for a 30 second period. Chiller shall remove any Return or Constant Return Chilled Water Reset, if it was in effect. Apply slew rates per Chilled Water Reset spec.	Remote
5E3	Comm Loss: Evaporator Leaving Water Temperature	Normal	Latch	Continual loss of communication between the MP and the Functional ID has occurred for a 30 second period.	Remote
688	Comm Loss: Evaporator Rfgt Liquid Level	Normal	Latch	Continual loss of communication between the MP and the Functional ID has occurred for a 30 second period.	Remote
5F0	Comm Loss: Evaporator Rfgt Pressure	Normal	Latch	Continual loss of communication between the MP and the Functional ID has occurred for a 30 second period.	Remote
5E1	Comm Loss: Ext Ice Building Control Input	Normal	Latch	Continual loss of communication between the MP and the Functional ID has occurred for a 30 second period. Chiller shall revert to normal (non-ice building) mode regardless of last state.	Remote
5DD	Comm Loss: External Auto/ Stop	Normal	Latch	Continual loss of communication between the MP and the Functional ID has occurred for a 30 second period.	Remote
6B6	Comm Loss: External Base Load Enable	Info and Special Action	Latch	Continual loss of communication between the MP and the Functional ID has occurred for a 30 second period. The external base load input is removed from the arbitration to enable Base Loading.	Remote
6B6	Comm Loss: External Base Load Setpoint Input	Info and Special Action	Latch	Continual loss of communication between the MP and the Functional ID has occurred for a 30 second period. The external base load setpoint input is removed from the arbitration to establish the Base LoadingSetpoint.	Remote

# Diagnostics

**Table 33 Diagnostic List**

<b>Hex Code</b>	<b>Diagnostic Name and Source</b>	<b>Severity</b>	<b>Persistence</b>	<b>Criteria</b>	<b>Reset Level</b>
5E9	Comm Loss: External Chilled Water Setpoint	Info and Special Action	NonLatch	Continual loss of communication between the MP and the Functional ID has occurred for a 30 second period. Chiller shall discontinue use of the External Chilled Water Setpoint source and revert to the next higher priority for setpoint arbitration	Remote
5EA	Comm Loss: External Current Limit Setpoint	Info and Special Action	NonLatch	Continual loss of communication between the MP and the Functional ID has occurred for a 30 second period. Chiller shall discontinue use of the External Current limit setpoint and revert to the next higher priority for Current Limit setpoint arbitration	Remote
5EB	Comm Loss: High Pressure Cutout Switch	Normal	Latch	Continual loss of communication between the MP and the Functional ID has occurred for a 30 second period.	Remote
5FA	Comm Loss: Ice-Making Status	Normal	Latch	Continual loss of communication between the MP and the Functional ID has occurred for a 30 second period. Chiller shall revert to normal (non-ice building) mode regardless of last state.	Remote
69D	Comm Loss: Local BAS Interface	Info and Special Action	Non Latch	Continual loss of communication between the MP and the Functional ID has occurred for a 30 second period. Use the last values sent from BAS	Remote
6B6	Comm Loss: Master Oil Line Solenoid Valve	Normal	Latch	Continual loss of communication between the MP and the Functional ID has occurred for a 30 second period.	Remote
6B6	Comm Loss: Oil Loss Level Input	Normal	Latch	Continual loss of communication between the MP and the Functional ID has occurred for a 30 second period.	Remote
5F4	Comm Loss: Oil Pressure	Normal	Latch	Continual loss of communication between the MP and the Functional ID has occurred for a 30 second period.	Remote
6B6	Comm Loss: Oil Return Gas Pump Drain	Normal	Latch	Continual loss of communication between the MP and the Functional ID has occurred for a 30 second period.	Remote
6B6	Comm Loss: Oil Return Gas Pump Fill	Normal	Latch	Continual loss of communication between the MP and the Functional ID has occurred for a 30 second period.	Remote
6A0	Comm Loss: Op Status Programmable Relays	Info	Latch	Continual loss of communication between the MP and the Functional ID has occurred for a 30 second period.	Remote
5E2	Comm Loss: Outdoor Air Temperature	Info and Special Action	Latch	Continual loss of communication between the MP and the Functional ID has occurred for a 30 second period. Note that if this diagnostic occurs, Chiller shall remove any OA Chilled Water Reset, if it was in effect and if Tracer OA was unavailable. Apply slew rates per Chilled Water Reset spec	Remote
6B6	Comm Loss: Refrigerant Monitor Input	Info	Latch	Continual loss of communication between the MP and the Functional ID has occurred for a 30 second period.	Remote

# Diagnostics

**Table 33 Diagnostic List**

<b>Hex Code</b>	<b>Diagnostic Name and Source</b>	<b>Severity</b>	<b>Persistence</b>	<b>Criteria</b>	<b>Reset Level</b>
5D2	Comm Loss: Slide Valve Load	Normal	Latch	Continual loss of communication between the MP and the Functional ID has occurred for a 30 second period.	Remote
5D1	Comm Loss: Slide Valve Unload	Normal	Latch	Continual loss of communication between the MP and the Functional ID has occurred for a 30 second period.	Remote
6B6	Comm Loss: Solid State Starter Fault Input	Info	Latch	Continual loss of communication between the MP and the Functional ID has occurred for a 30 second period.	Remote
690	Comm Loss: Starter	Immediate	Latch	Continual loss of communication between the MP and the Functional ID has occurred for a 30 second period.	Local
1F5	Compressor Did Not Accelerate Fully	Immediate	Latch	The starter module did not receive an "Up to Speed" or "End of Ramp" signal from the SSS within 2.5 seconds after commanding a bypass, or after the maximum acceleration time had expired, whichever is longer. This diagnostic only applies to SSS.	Local
EE	Compressor Did Not Accelerate: Shutdown	Immediate	Latch	The compressor did not come up to speed (get to <85%RLA) in the allotted time defined by the Maximum Acceleration Timer and the start was aborted per the starter configuration selected.	Remote
1FA	Compressor Did Not Accelerate: Transition	Info	Latch	The compressor did not come up to speed (get to <85%RLA) in the allotted time defined by the Maximum Acceleration Timer and a transition was forced (motor put across the line) at that time. This applies to all starter types. Note: Since RTHD SSS has no forced transition capability, this info warning can be followed with a "Compressor did not accelerate fully " diagnostic above and an aborted start.	Remote
284	Compressor Discharge Temperature Sensor	Immediate	Latch	Bad Sensor or LLID	Remote
9A	Condenser Entering Water Temperature Sensor	Info and Special Action	Latch	Bad Sensor or LLID. If chiller running, and condenser water regulating valve option installed, force valve to 100% flow.	Remote
9B	Condenser Leaving Water Temperature Sensor	Info	Latch	Bad Sensor or LLID	Remote
5B8	Condenser Refrigerant Pressure Transducer	Normal	Latch	Bad Sensor or LLID	Remote

# Diagnosics

**Table 33 Diagnostic List**

<b>Hex Code</b>	<b>Diagnostic Name and Source</b>	<b>Severity</b>	<b>Persistence</b>	<b>Criteria</b>	<b>Reset Level</b>
F7	Condenser Water Flow Lost	Immediate	NonLatch	The condenser water flow proof input was open for more than 6 contiguous seconds after flow had been proven. This diagnostic is automatically cleared once the compressor is stopped by a fixed time out of 7 sec. The Cond Pump shall be commanded off but the Evap pump command will not be effected.	Remote
DC	Condenser Water Flow Overdue	Normal	NonLatch	Condenser water flow was not proven within 20 minutes of the condenser pump relay being energized. The Cond Pump shall be commanded off. Diagnostic is reset with return of flow (although only possible with external control of pump)	Remote
EC or EC	Current Overload Trip/Motor Current Overload	Immediate	Latch	Compressor current exceeded overload time vs. trip characteristic. For A/C products Must trip = 140% RLA, Must hold=125%, nominal trip 132.5% in 30 seconds	Local
FD	Emergency Stop	Immediate	Latch	a. EMERGENCY STOP input is open. An external interlock has tripped. Time to trip from input opening to unit stop shall be 0.1 to 1.0 seconds.	Local
8E	Evaporator Entering Water Temperature Sensor	Info	Latch	Bad Sensor or LLID Normal operation unless CHW Reset is enabled. If CHW Reset is enabled and either Return or Constant Return Chilled Water Reset is selected, its effect will be removed but slew rates on the change will be limited per the Chilled Water Reset spec.	Remote
AB	Evaporator Leaving Water Temperature Sensor	Normal	Latch	Bad Sensor or LLID	Remote
27D	Evaporator Liquid Level Sensor	Normal	Latch	Bad Sensor or LLID	Remote
5BA	Evaporator Refrigerant Pressure Transducer	Normal	Latch	Bad Sensor or LLID	Remote
ED	Evaporator Water Flow Lost	Immediate	NonLatch	The chilled water flow proof input was open for more than 6-10 contiguous seconds after flow had been proven. The pump command status will not be effected. 6-10 seconds of contiguous flow shall clear this diagnostic. Even though the pump may be commanded to run in the STOP modes (pump off delay time), this diagnostic shall not be called out in the STOP modes.	Remote
384	Evaporator Water Flow Overdue	Normal	NonLatch	Evaporator water flow was not proven within 20 minutes of the Chilled water pump relay being energized. The Evap pump command status will not be effected.	Remote



# Diagnostics

**Table 33 Diagnostic List**

Hex Code	Diagnostic Name and Source	Severity	Persistence	Criteria	Reset Level
5C4	Excessive Loss of Comm	Immediate	Latch	Loss of comm with 20% or more of the llids configured for the system has been detected. This diagnostic will suppress the callout of all subsequent comm loss diagnostics. Check power supply(s) and power disconnects - troubleshoot LLIDS buss using TechView	Remote
4C4	External Base Loading Setpoint	Info and Special Action	NonLatch	a. Not "Enabled": no diagnostics. b. "Enabled ": Out-Of-Range Low or Hi or bad LLID, set diagnostic, default BLS to next level of priority (e.g. Front Panel SetPoint). This Info diagnostic will automatically reset if the input returns to the normal range.	Remote
87	External Chilled Water Setpoint	Info	NonLatch	a. Function Not "Enabled": no diagnostics. b. "Enabled ": Out-Of-Range Low or Hi or bad LLID, set diagnostic, default CWS to next level of priority (e.g. Front Panel SetPoint). This Info diagnostic will automatically reset if the input returns to the normal range.	Remote
89	External Current Limit Setpoint	Info	NonLatch	a. Not "Enabled": no diagnostics. b. "Enabled ": Out-Of-Range Low or Hi or bad LLID, set diagnostic, default CLS to next level of priority (e.g. Front Panel SetPoint). This Info diagnostic will automatically reset if the input returns to the normal range.	Remote
1C2	High Compressor Discharge Temperature	Immediate	Latch	The compressor discharge temperature exceeded 190°F. This diagnostic will be suppressed if it occurs during the compressor run-unload period or after the compressor has stopped, but a run unload will be terminated early as a result. Note: As part of the Compressor High Temperature Limit Mode (aka Minimum Capacity Limit), the compressor shall be forced loaded as the filtered discharge temperature nears this trip-point.	Remote
1C6	High Differential Refrigerant Pressure	Normal	Latch	a. The system differential pressure was above 160 Psid- trip immediately (normal shutdown) B The diff pressure was above 152 Psid - trip in 1 hour	Remote
584	High Evaporator Liquid Level	Normal	Latch	The liquid level sensor is seen to be at or near its high end of range for 80 contiguous minutes while the compressor is running. (The diagnostic timer will hold, but not clear when the circuit is off). Design: 80% or more of bit count corresponding to +21.2 mm or more liquid level for 80 minutes)	Remote
6B8	High Evaporator Refrigerant Pressure	Immediate and Special Action	NonLatch	The evaporator refrigerant pressure has risen above 190 psig. The evaporator water pump relay will be de-energized to stop the pump regardless of why the pump is running. The diagnostic will auto reset and the pump will return to normal control when the evaporator pressures falls below 185 psig. This diagnostic must shutdown the chiller if it is running.	Local

# Diagnosics

**Table 33 Diagnostic List**

<b>Hex Code</b>	<b>Diagnostic Name and Source</b>	<b>Severity</b>	<b>Persistence</b>	<b>Criteria</b>	<b>Reset Level</b>
F5	High Pressure Cutout	Immediate	Latch	A high pressure cutout was detected; C.O. on rise @ 180 psig, reset @ 135 psig (+/-5 psi on switching tolerance) Note: Pressure relief valve is 200 Psig +/- 2% trip at 315 ± 5 psi. Note: Other diagnostics that may occur as an expected consequence of the HPC trip will be suppressed from annunciation. These include Phase Loss, Power Loss, and Transition Complete Input Open.	Local
1C6	High Refrigerant Pressure Ratio	Immediate	Latch	The system pressure ratio exceeded 5.61 for 1 contiguous minute. This pressure ratio is a fundamental limitation of the compressor. The pressure ratio is defined as Pcond (abs)/Pevap(abs).	Remote
59C	Loss of Oil at Compressor (Running)	Immediate	Latch	In running modes , Oil Loss Level Sensor detects lack of oil in the oil tank feeding the compressor (distinguishing a liquid flow from a vapor flow)	Local
59D	Loss of Oil at Compressor (Stopped)	Immediate and Special Action	Latch	Oil Loss Level Sensor detects a lack of oil in the oil tank feeding the compressor for 90 seconds after EXV preposition is completed. Note: Compressor start is delayed while waiting for oil to be detected.	Local
C5	Low Chilled Water Temp: Unit Off	Info and Special Action	NonLatch	The leaving chilled water temp. fell below the leaving water temp cutout setting for 30 degree F seconds while the Chiller is in the Stop mode, or in Auto mode with no compressors running. Energize Evap Water pump Relay until diagnostic auto resets, then return to normal evap pump control. Automatic reset occurs when the temp rises 2°F (1.1°C) above the cutout setting for 30 minutes.	Remote
C6	Low Chilled Water Temp: Unit On	Immediate and Special Action	NonLatch	The chilled water temp. fell below the cutout setpoint for 30 degree F Seconds while the compressor was running. Automatic reset occurs when the temperature rises 2 °F (1.1°C) above the cutout setting for 2 minutes. This diagnostic shall not de-energize the Evaporator Water Pump Output.	Remote
1AE	Low Differential Refrigerant Pressure	Immediate	Latch	The system differential pressure was either below 15 Psid for more than 164 Psid-sec, or below 23.0 Psid for 3000 Psid-sec. The latter integral's value is not cleared for any reason including diagnostic trip, manual reset, or power up reset (ie. Integral is saved nonvolatily on power down). The integral will decay while circuit is running at a max rate of -10 PSID, and while stopped at a rate of -0.4 PSID. This same integral is associated with the operating mode "Compressor Cool Down". Also see diagnostic below	Remote
18E	Low Discharge Superheat	Normal	Latch	While Running Normally, the Discharge Superheat was less than 12 degrees F +/- 1F for more than 6500 degree F seconds.. At startup the UCM shall ignore the Discharge Superheat for 5.	Remote

# Diagnostics

**Table 33 Diagnostic List**

Hex Code	Diagnostic Name and Source	Severity	Persistence	Criteria	Reset Level
583	Low Evaporator Liquid Level	Info	NonLatch	The liquid level sensor is seen to be at or near its low end of range for 80 contiguous minutes while the compressor is running. Design: 20% or less of bit count corresponding to -21.2 mm or less liquid level for 80 minutes)	Remote
B5	Low Evaporator Refrigerant Pressure	Immediate	Latch	The Evaporator Refrigerant Pressure dropped below 10 psia just prior to compressor start. The pressure fell below 10 psia while running but before the 1 minute ignore time had expired or fell below 16 Psia after the 1 minute ignore time had expired.	Local
FB	Low Evaporator Refrigerant Temperature	Immediate	Latch	a. The inferred Saturated Evap Refrigerant Temperature (calculated from suction pressure transducer(s)) dropped below the Low Refrigerant Temperature Cutout Setpoint for 450°F-sec (10°F-sec max rate) while the circuit was running after the ignore period had expired. The integral is held at zero for the 1 minute ignore time following the circuit startup and the integral will be limited to never trip in less than 45 seconds, i.e. the error term shall be clamped to 10°F. The minimum LRTC setpoint is -5°F (18.7 Psia) the point at which oil separates from the refrigerant. b. During the timeout of the trip integral, the unload solenoid(s) of the running compressors on the circuit, shall be energized continuously and the load solenoid shall be off. Normal load/unload operation will be resumed if the trip integral is reset by return to temps above the cutout setpoint.	Remote
6B3	Low Evaporator Temp: Unit Off	Info and Special Action	NonLatch	The evap sat temp fell below the water temp cutout setting while the respective evap liquid level was greater than -21.2mm for 30 degree F seconds while Chiller is in the Stop mode, or in Auto mode with no compressors running. Energize Evap Water pump Relay until diagnostic auto resets, then return to normal evap pump control. Automatic reset occurs when either the evap temp rises 2°F (1.1°C) above the cutout setting or the liquid level falls below -21.2mm for 30 minutes	Remote
198	Low Oil Flow	Immediate	Latch	The oil pressure was out of the acceptable pressure range for 15 seconds, while the Delta Pressure was greater than 23.8 Psid.: Acceptable range is 0.50 > (PC-Po) / (PC-PE) for the first 2.5 minutes of operation, and 0.40 > (PC-Po) / (PC-PE) thereafter,	Local
E2	Momentary Power Loss	Immediate	Nonlatch	Momentary Power Loss option disabled: No effect. Momentary Power Loss option enabled: A loss of power on three line cycles or more was detected. Diagnostic is reset in 30 seconds. See Momentary Power Loss Protection specification for additional information.	Remote

# Diagnostics

**Table 33 Diagnostic List**

<b>Hex Code</b>	<b>Diagnostic Name and Source</b>	<b>Severity</b>	<b>Persistence</b>	<b>Criteria</b>	<b>Reset Level</b>
1AD	MP Application Memory CRC Error	Immediate	Latch	App software inside the MP failed its own checksum test. Possible causes: application software in the MP is not complete - software download to the MP was not completed successfully - or MP hardware problem. Note: User should attempt to reprogram the MP if this diagnostic occurs.	Remote
6A1	MP: Could not Store Starts and Hours	Info	Latch	MP has determined there was an error with the previous power down store. Starts and Hours may have been lost for the last 24 hours.	Remote
5FF	MP: Invalid Configuration	Immediate	Latch	MP has an invalid configuration based on the current software installed	Remote
6A2	MP: Non-Volatile Block Test Error	Info	Latch	MP has determined there was an error with a block in the Non-Volatile memory. Check settings.	Remote
69C	MP: Non-Volatile Memory Reformat	Info	Latch	MP has determined there was an error in a sector of the Non-Volatile memory and it was reformatted. Check settings.	Remote
D9	MP: Reset Has Occurred	Info	NonLatch	The main processor has successfully come out of a reset and built its application. A reset may have been due to a power up, installing new software or configuration. This diagnostic is immediately and automatically cleared and thus can only be seen in the Historic Diagnostic List in TechView	Remote
297	No Differential Refrigerant Pressure	Immediate	Latch	The system differential pressure was below 7.7 Psid. The occurrence of this diagnostic will saturate the above "Low Diff Rfght Press" Integral and invoke the same "Compressor Cool Down" op mode.	Remote
1E1	Oil Flow Protection Fault	Immediate	Latch	The Oil Pressure Transducer for this Chiller is reading a pressure either above its Condenser Pressure by 15 Psia or more, or below its Evaporator Pressure 10 Psia or more for 30 seconds continuously.	Local
5BE	Oil Pressure Transducer	Normal	Latch	Bad Sensor or LLID	Remote
A1	Outdoor Air Temperature Sensor	Info and Special Action	Latch	Bad Sensor or LLID. This diagnostic will only occur if OA sensor is configured.OA Chilled water reset will be suspended if selected and Tracer OA unavailable.	Remote
D7	Over Voltage	Normal	NonLatch	a. Average of all monitored Line voltages above + 10% of nominal. [Must hold = + 10 % of nominal. Must trip = + 15 % of nominal. Reset differential = min. of 2% and max. of 4%. Time to trip = minimum of 1 min. and maximum of 5 min.) Design: Nom. trip: 60 seconds at greater than 112.5%, + or - 2.5%, Auto Reset at 109% or less.	Remote

# Diagnostics

**Table 33 Diagnostic List**

<b>Hex Code</b>	<b>Diagnostic Name and Source</b>	<b>Severity</b>	<b>Persistence</b>	<b>Criteria</b>	<b>Reset Level</b>
E4	Phase Loss	Immediate	Latch	a) No current was sensed on one or two of the current transformer inputs while running or starting (See Nonlatching Power Loss Diagnostic for all three phases lost while running). Must hold = 20% RLA. Must trip = 5% RLA. Time to trip shall be longer than guaranteed reset on Starter Module at a minimum, 3 seconds maximum. Actual design trippoint is 10%. The actual design trip time is 2.64 seconds. b) If Phase reversal protection is enabled and current is not sensed on one or more current xformer inputs. Logic will detect and trip in a maximum of 0.3 second from compressor start.	Local
E5 or E5	Phase Reversal	Immediate	Latch	A phase reversal was detected on the incoming current. On a compressor startup the phase reversal logic must detect and trip in a maximum of 0.3 second from compressor start.	Local
E3	Phase UnbalanceSevere Current Imbalance	Normal	Latch	A 30% Phase cCurrent Unbalance imbalance has been detected on one phase relative to the average of all 3 phases for 90 continuous seconds.	Local
1A0	Power Loss	Immediate	NonLatch	The compressor had previously established currents while running and then all three phases of current were lost. Design: Less than 10% RLA, trip in 2.64 seconds. This diagnostic will preclude the Phase Loss Diagnostic and the Transition Complete Input Opened Diagnostic from being called out. To prevent this diagnostic from occurring with the intended disconnect of main power, the minimum time to trip must be greater than the guaranteed reset time of the Starter module. Note: This diagnostic prevents nuisance latching diagnostics due to a momentary power loss - It does not protect motor/compressor from uncontrolled power reapplication. See Momentary Power Loss Diagnostic for this protection. This diagnostic will auto reset in 10 seconds from its occurrence, and is not active during the start mode before the transition complete input is proven. This prevents the chiller from cycling due to some internal starter problem, as the starter would latch out on either a "Starter Fault Type 3" or a "Starter Did Not Transition" latching diagnostic. However true power loss occurring during a start would result in a misdiagnosis and the chiller would not automatically recover.	Remote
2F2	Refrigerant Monitor Sensor	Info	NonLatch	Open or Shorted input and the Rfght Monitor is setup as installed	Remote
28C	Restart Inhibit Warning	Info	NonLatch	The Restart Inhibit was invoked on a compressor. This indicates excessive chiller cycling which should be corrected.	Remote
189	Solid State Starter Fault	Immediate	Latch	The Solid State Starter Fault Relay is open	Local

# Diagnostics

**Table 33 Diagnostic List**

Hex Code	Diagnostic Name and Source	Severity	Persistence	Criteria	Reset Level
188	Starter Dry Run Test	Immediate	Latch	While in the Starter Dry Run Mode either 50 % Line Voltage was sensed at the Potential Transformers or 10 % RLA Current was sensed at the Current Transformers.	Local
5CD	Starter Comm Loss with MP	Immediate	Latch	Starter has had a loss of communication with the MP for a 15 second period.	Local
CA	Starter Contactor Interrupt Failure	Immediate and Special Mode Action	Latch	Detected compressor currents greater than 10% RLA on any or all phases when the compressor was commanded off. Detection time shall be 5 seconds minimum and 10 seconds maximum. On detection and until the controller is manually reset: generate diagnostic, energize the appropriate alarm relay, continue to energize the Evap and Cond Pump Outputs, continue to command the affected compressor off, fully unload the effected compressor. For as long as current continues, perform liquid level and oil return gas pump control	Local
F0	Starter Did Not Transition	Immediate	Latch	The Starter Module did not receive a transition complete signal in the designated time from its command to transition. The must hold time from the Starter Module transition command is 1 second. The Must trip time from the transition command is 6 seconds. Actual design is 2.5 seconds. This diagnostic is active only for Y-Delta, Auto-Transformer, Primary Reactor, and X-Line Starters.	Local
6A3	Starter Failed to Arm/Start	Info	Latch	Starter failed to arm or start within the allotted time (15 seconds).	Remote
1E9	Starter Fault Type I	Immediate	Latch	This is a specific starter test where 1M(1K1) is closed first and a check is made to ensure that there are no currents detected by the CT's. If currents are detected when only 1M is closed first at start, then one of the other contactors is shorted.	Local
1ED	Starter Fault Type II	Immediate	Latch	a. This is a specific starter test where the Shorting Contactor (1K3) is individually energized and a check is made to ensure that there are no currents detected by the CT's. If current is detected when only S is energized at Start, then 1M is shorted. b. This test in a. above applies to all forms of starters (Note: It is understood that many starters do not connect to the Shorting Contactor.).	Local
1F1	Starter Fault Type III	Immediate	Latch	As part of the normal start sequence to apply power to the compressor, the Shorting Contactor (1K3) and then the Main Contactor (1K1) were energized. 1.6 seconds later there were no currents detected by the CT's for the last 1.2 seconds on all three phases. The test above applies to all forms of starters except Adaptive Frequency Drives.	Local
5C5	Starter Module Memory Error Type 1	Info	Latch	Checksum on RAM copy of the Starter LLID configuration failed. Configuration recalled from EEPROM.	Local

# Diagnostics

**Table 33 Diagnostic List**

<b>Hex Code</b>	<b>Diagnostic Name and Source</b>	<b>Severity</b>	<b>Persistence</b>	<b>Criteria</b>	<b>Reset Level</b>
5C9	Starter Module Memory Error Type 2 -	Immediate	Latch	Checksum on EEPROM copy of the Starter LLID configuration failed. Factor default values used.	Local
3D7	Transition Complete Input Opened	Immediate	Latch	The Transition Complete input is open with the compressor motor running after a successful completion of transition. This is active only for all electromechanical starters	Local
3D5	Transition Complete Input Shorted	Immediate	Latch	The Transition Complete input is shorted before the compressor was started. This is active for all electromechanical starters.	Local
D8	Under Voltage	Normal	NonLatch	a. Average of all monitored Line voltages below - 10% of nominal or the Under/Overtoltage transformer(s) are not connected. [Must hold = - 10 % of nominal. Must trip = - 15 % of nominal. Reset differential = min. of 2% and max. of 4%. Time to trip = min. of 1 min. and max. of 5 min.) Design: Nom. trip: 60 seconds at less than 87.5%, + or - 2.8% at 200V or + or - 1.8% at 575V, Auto Reset at 90% or greater.	Remote



# Diagnostics

---



## Wiring Schematics

---

Typical field connection diagrams, electrical schematics for the RTHD units are shown in this section.

*NOTE: The drawings in this section are provided for reference only. These diagrams may not reflect the actual wiring of your unit. For specific electrical connection and schematic information, always refer to the wiring diagrams that were shipped with the unit.*

### Unit Electrical Data

To determine the specific electrical characteristics of a particular chiller, refer to the nameplates mounted on the units.

<b>Drawing</b>	<b>Description</b>	<b>IOM Page</b>
2309-7552	Schematic, page 1 - WYE-DELTA Starter	<a href="#">160</a>
2309-7553	Schematic, page 2 - WYE-DELTA Starter	<a href="#">162</a>
2309-7554	Schematic, page 3 - WYE-DELTA Starter	<a href="#">164</a>
2309-7555	Schematic, page 4 - WYE-DELTA Starter	<a href="#">166</a>
2309-1360	Schematic, page 1 - SOLID STATE Starter	<a href="#">168</a>
2309-1361	Schematic, page 2 - SOLID STATE Starter	<a href="#">170</a>
2309-1362	Schematic, page 3 - SOLID STATE Starter	<a href="#">172</a>
2309-1363	Schematic, page 4 - SOLID STATE Starter	<a href="#">174</a>
2309-7564	Component Location	<a href="#">176</a>
2309-7565	Component Location - Solid State Starter	<a href="#">177</a>
2309-4870	Field Wiring	<a href="#">178</a>
2309-4869	Field Layout	<a href="#">180</a>

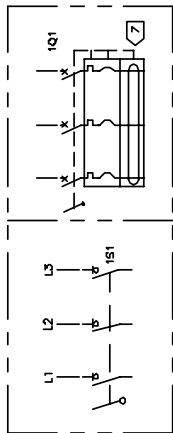

**WARNING**  
HAZARDOUS VOLTAGE!  
DISCONNECT ALL ELECTRIC POWER INCLUDING REMOTE DISCONNECTS BEFORE SERVICING.  
INSURE THAT ALL MOTOR CAPACITORS HAVE DISCHARGED STORED VOLTAGE UNITS WITH TO DRIVE INSTRUCTIONS FOR CAPACITOR DISCHARGE.  
FAILURE TO DO THE ABOVE BEFORE SERVICING COULD RESULT IN DEATH OR SERIOUS INJURY.

**AVERTISSEMENT**  
TENSION DANGEREUSE!  
COUPER TOUTES LES TENSIONS ET INCLUSE LES SECTIONNEURS A DISTANCE, AVANT DE FAIRE LE TRAVAIL. ASSUREZ-VOUS QUE TOUS LES CONDENSATEURS DES MOTEURS SONT DECHARGES. DANS LE CAS D'UNITES DE STOCKAGE DE TENSION, SUIVEZ LES INSTRUCTIONS POUR LE DECHARGEMENT DU CONDENSATEUR.  
NE PAS RESPECTER CES MESURES DE PRECAUTION PEUT ENTRAINER DES BLESSURES GRAVES POUVANT ETRE MORTELLES.

**ADVERTENCIA**  
VOLTAJE PELIGROSO!  
DESCONECTE TODA LA ENERGIA ELECTRICA, INCLUIDO LAS DESCONEXIONES REMOTAS Y LAS SECCIONNEURAS A DISTANCIA, ANTES DE PROCEDER AL SERVICIO. ASEGURESE DE QUE TODOS LOS CAPACITORES DEL MOTOR HAYAN DESCARGADO EL VOLTAJE ALMACENADO. EN EL CASO DE UNIDADES DE ALMACENAMIENTO DE ENERGIA, SIGA LAS INSTRUCCIONES PARA LA DESCARGA DEL CONDENSADOR.  
EL NO REALIZAR LO ANTERIORMENTE INDICADO, PODRIA OCASIONAR LA MUERTE O SERIAS LESIONES PERSONALES.

**CAUTION**  
USE COPPER CONDUCTORS ONLY!  
UNIT TERMINALS ARE NOT DESIGNED TO ACCEPT OTHER TYPES OF CONDUCTORS.  
FAILURE TO DO SO MAY CAUSE DAMAGE TO THE EQUIPMENT.

**PRECAUCIÓN**  
N'UTILISER QUE DES CONDUCTEURS EN CUIVRE!  
LES BORNES DE L'UNITÉ NE SONT PAS CONÇUES POUR RECEVOIR D'AUTRES TYPES DE CONDUCTEURS.  
L'UTILISATION DE TOUT AUTRE CONDUCTEUR PEUT ENDOMMAGER L'EQUIPEMENT.

**ATTENTION**  
!UTILICE ÚNICAMENTE CONDUCTORES DE COBRE!  
LAS TERMINALES DE LA UNIDAD NO ESTÁN DISEÑADAS PARA ACEPTAR OTROS TIPOS DE CONDUCTORES.  
SI NO LO HACE, PUEDE OCASIONAR DAÑO AL EQUIPO.

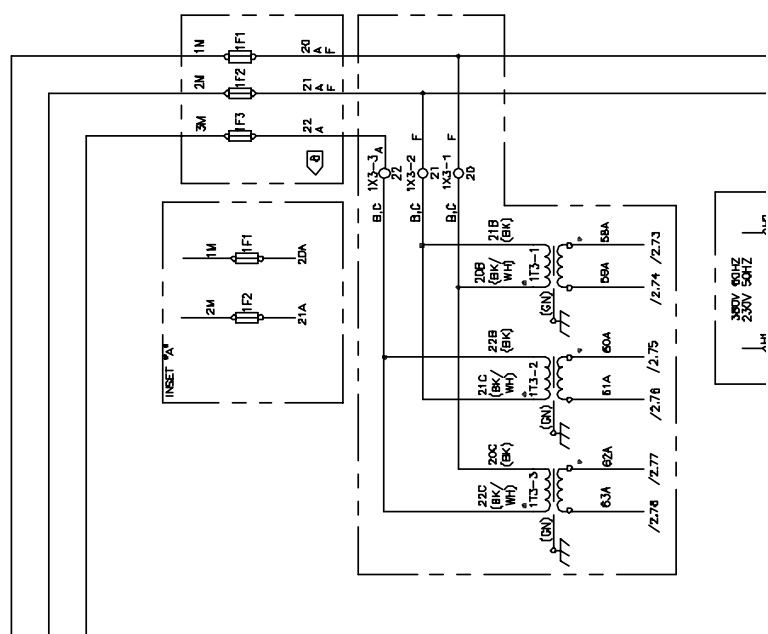
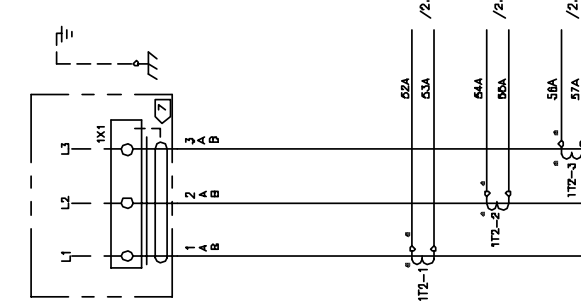

- 1 —
- 2 —
- 3 —
- 4 —
- 5 —
- 6 —
- 7 —
- 8 —
- 9 —
- 10 —
- 11 —
- 12 —
- 13 —
- 14 —
- 15 —
- 16 —
- 17 —
- 18 —
- 19 —
- 20 —
- 21 —
- 22 —
- 23 —
- 24 —
- 25 —
- 26 —
- 27 —
- 28 —
- 29 —
- 30 —
- 31 —
- 32 —
- 33 —
- 34 —
- 35 —
- 36 —
- 37 —

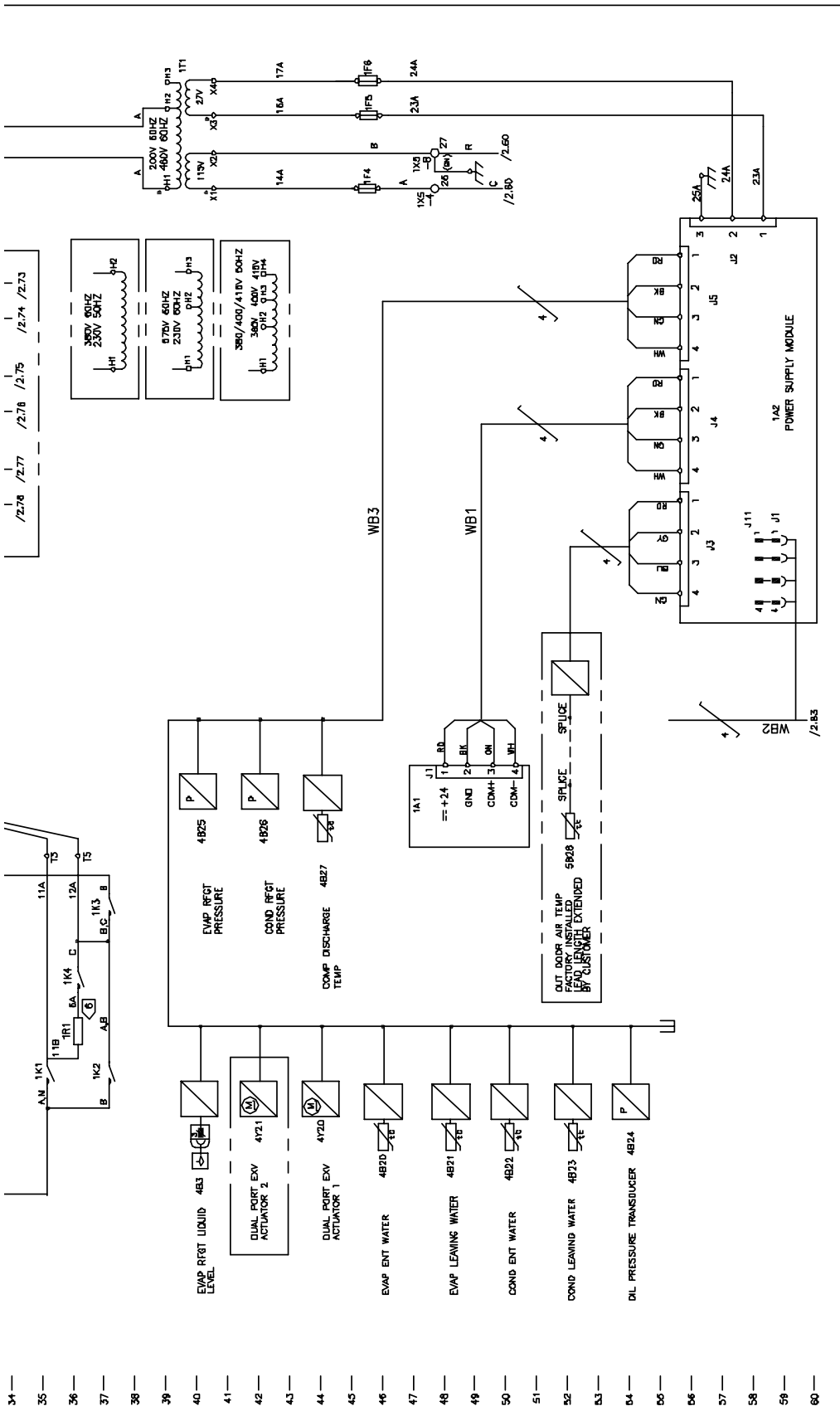

34 —  
 35 —  
 36 —  
 37 —  
 38 —  
 39 —  
 40 —  
 41 —  
 42 —  
 43 —  
 44 —  
 45 —  
 46 —  
 47 —  
 48 —  
 49 —  
 50 —  
 51 —  
 52 —  
 53 —  
 54 —  
 55 —  
 56 —  
 57 —  
 58 —  
 59 —  
 60 —

2309-7553  
 SCHEMATIC WIRING  
 RTHD

WTE-BETA STARTER

REPLACES:  
 SERIAL TO 2308-7561

**CAUTION**  
 USE COPPER CONDUCTORS ONLY.  
 UNIT TERMINALS ARE NOT DESIGNED TO ACCEPT  
 OTHER TYPES OF CONDUCTORS.  
 FAILURE TO DO SO MAY CAUSE DAMAGE TO THE  
 EQUIPMENT.

**ATTENTION**  
 N'UTILISER QUE DES CONDUCTEURS EN CUIVRE!  
 LES BORNES DE L'UNITÉ NE SONT PAS CONÇUES  
 POUR RECEVOIR D'AUTRES TYPES DE CONDUCTEURS.  
 L'UTILISATION DE TOUT AUTRE CONDUCTEUR PEUT  
 ENDOMMAGER L'ÉQUIPEMENT.

**PRECAUCIÓN**  
 ÚTILICE ÚNICAMENTE CONDUCTORES DE COBRE!  
 LAS TERMINALES DE LA UNIDAD NO ESTÁN DISEÑADAS  
 PARA ACEPTAR OTROS TIPOS DE CONDUCTORES.  
 SI NO LO HACE, PUEDE OCASIONAR DAÑO AL EQUIPO.

**WARNING**  
 HAZARDOUS VOLTAGE!  
 DISCONNECT ALL ELECTRIC POWER  
 INCLUDING REMOTE DISCONNECTS AND  
 LOCKOUT TAGOUT BEFORE WORKING ON THIS  
 EQUIPMENT. ALWAYS WEAR APPROPRIATE  
 BEFORE SERVICING. INSURE THAT ALL  
 MOTOR CAPACITORS HAVE DISCHARGED  
 BEFORE WORKING. UNITS WITH VARIABLE  
 SPEED DRIVE REFER TO DRIVE  
 INSTRUCTIONS FOR CAPACITOR DISCHARGE.  
 FAILURE TO DO THE ABOVE BEFORE  
 WORKING ON THIS EQUIPMENT COULD RESULT IN DEATH OR  
 SERIOUS INJURY.

**AVERTISSEMENT**  
 TENSION DANGEREUSE!  
 COUPER TOUJOURS LES TENSIONS ET  
 QUARRER LES SECTIONNEURS A DISTANCE,  
 PUIS SUIVRE LES PROCEDURES DE

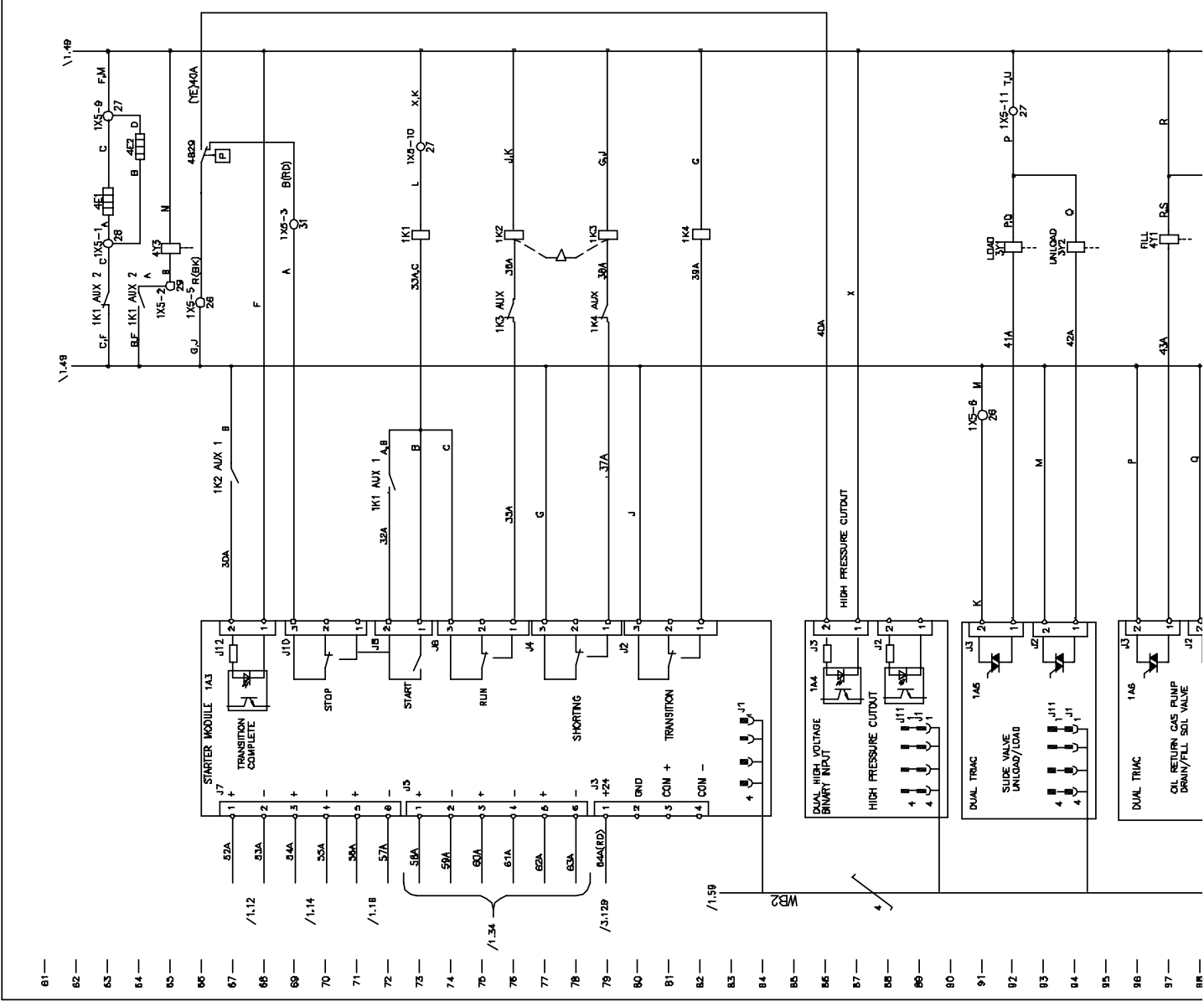

**WARNING**

HAZARDOUS VOLTAGE!  
DISCONNECT ALL ELECTRIC POWER INCLUDING REMOTE DISCONNECTS AND LOCK/TAG OUT BEFORE WORKING ON ANY ELECTRICAL CIRCUIT. INSURE THAT ALL MOTOR CAPACITORS HAVE DISCHARGED STORED VOLTAGE. UNITS WITH VARIABLE SPEED DRIVE REFER TO DRIVE INSTRUCTIONS FOR CAPACITOR DISCHARGE. FAILURE TO DO THIS ABOVE BEFORE WORKING ON THE CIRCUIT COULD RESULT IN DEATH OR SERIOUS INJURY.

**AVERTISSEMENT**

TENSION DANGEREUSE!  
COUPER TOUTES LES TENSIONS ET OUVRIRE LES SECTIONNEURS A DISTANCE, PUIS SUIVRE LES PROCEDURES DE VERROUILLAGE ET DES ETIQUETES AVANT TOUTE INTERVENTION. VERIFIER QUE TOUTS LES CONDENSATEURS DES MOTEURS SONT DECHARGES DANS LE CAS D'UNITES COMPORTANT DES ENTRAINEMENTS A VITESSE VARIABLE. SE REPORTER AUX INSTRUCTIONS DE L'ENTRAINEMENT POUR DECHARGER LES CONDENSATEURS. LE PAS RESPECTER CES MESURES DE PRECAUTION PEUT ENTRAÎNER LA MORT OU DES BLESSES GRAVES POUVANT ETRE MORTELLES.

**ADVERTENCIA**

VOLTAJE PELIGROSO!  
DESCONECTE TODA LA ENERGIA ELECTRICA INCLUIDO LAS DESCONEXIONES REMOTAS Y SIGA LOS PROCEDIMIENTOS DE CIERRE Y ETIQUETADO ANTES DE PROCEDER AL TRABAJO. VERIFIQUE QUE TODOS LOS CAPACITORES DEL MOTOR HAYAN DESCARGADO EL VOLTAJE ALMACENADO. PARA LAS UNIDADES CON EJE DE VELOCIDAD VARIABLE, CONSULTE LAS INSTRUCCIONES PARA LA DESCARGA DEL CONDENSADOR. EL NO REALIZAR LO ANTERIORMENTE INDICADO, PODRIA OCASIONAR LA MUERTE O SERIAS LESIONES PERSONALES.

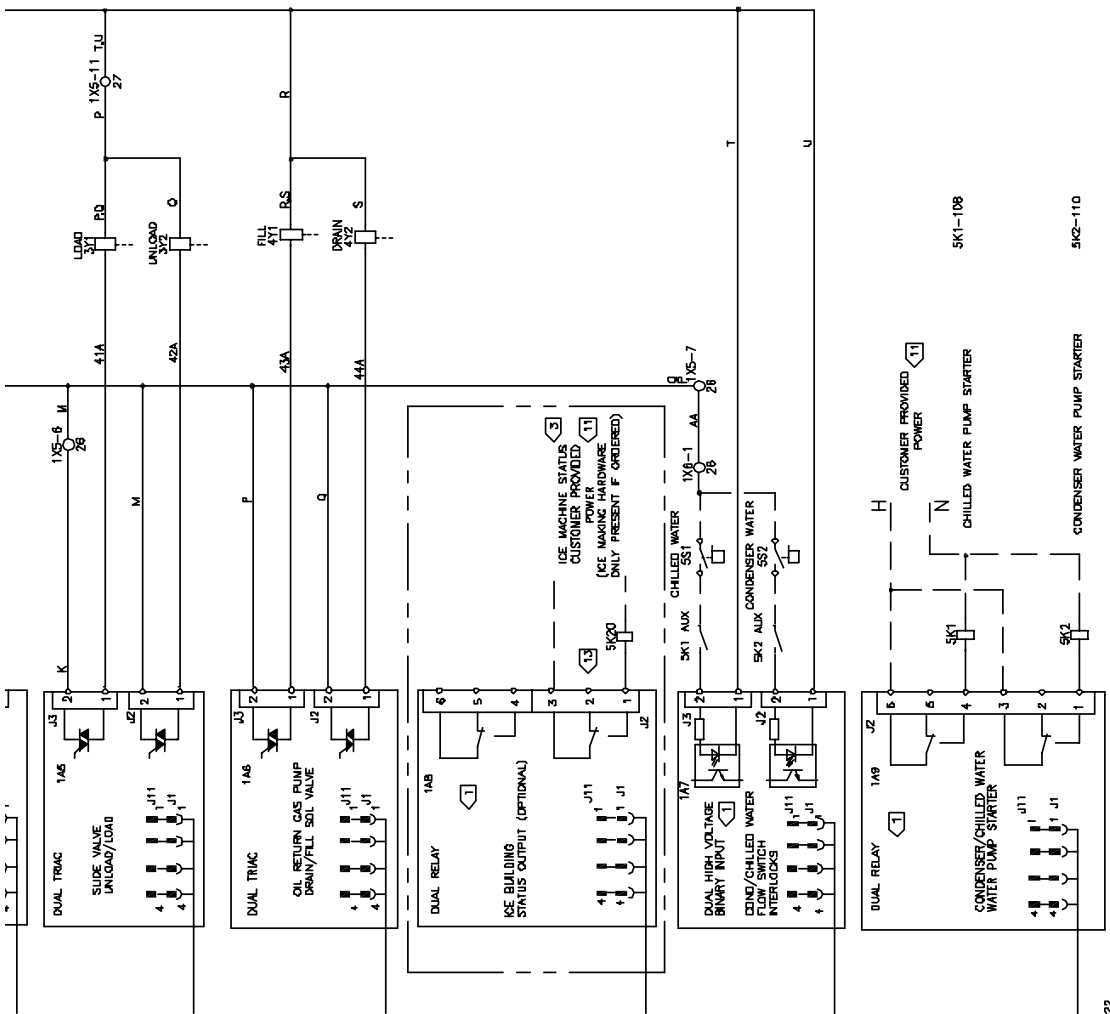

/3.122

- 90 —
- 91 —
- 92 —
- 93 —
- 94 —
- 95 —
- 96 —
- 97 —
- 98 —
- 99 —
- 100 —
- 101 —
- 102 —
- 103 —
- 104 —
- 105 —
- 106 —
- 107 —
- 108 —
- 109 —
- 110 —
- 111 —
- 112 —
- 113 —
- 114 —
- 115 —
- 116 —
- 117 —
- 118 —
- 119 —
- 120 —

**WARNING**  
HAZARDOUS VOLTAGE!  
DISCONNECT ALL ELECTRIC POWER INCLUDING REMOTE DISCONNECTS AND LOCKOUT TAGOUT PROCEDURES BEFORE SERVICING. INSURE THAT MOTOR CAPACITORS HAVE DISCHARGED. STORED VOLTAGE UNITS WITH VARIABLE SPEED DRIVE REFER TO DRIVE INSTRUCTIONS FOR CAPACITOR DISCHARGE. FAILURE TO DO THE ABOVE BEFORE SERVICING CAN RESULT IN DEATH OR SERIOUS INJURY.

**AVERTISSEMENT**  
TENSION DANGEREUSE!  
COUPER TOUTES LES TENSIONS ET COUVRIR LES SECTIONNEURS A DISTANCE. PUIS SUIVRE LES PROCEDURES DE VERROUILLAGE ET DES ETIQUETTES AVANT TOUTE INTERVENTION. VERIFIER QUE TOUS LES CONDENSATEURS ONT BIEN ETE DECHARGES. DANS LE CAS D'UNITES COMPORTANT DES ENTRAÎNEMENTS A VITESSE VARIABLE, SE REPORTER AUX INSTRUCTIONS DE L'ENTRAÎNEMENT POUR DECHARGER LES CONDENSATEURS. NE PAS RESPECTER CES MESURES DE SECURITE PEUT CAUSER LA MORT OU DES BLESSURES GRAVES POUVANT ETRE MORTELLES.

**ADVERTENCIA**  
¡VOLTAJE PELIGROSO!  
DESCONECTE TODA LA ENERGIA ELECTRICA INCLUIDO LAS DESCONEXIONES REMOTAS Y SIGA LOS PROCEDIMIENTOS DE CERRJE Y VERROUILLAJE Y ETIQUETAS ANTES DE SERVICIAR. ASEGURESE DE QUE TODOS LOS CAPACITORES DEL MOTOR HAYAN DESCARGADO EL VOLTAJE ALMACENADO. PARA LAS UNIDADES CON EJE DE ENTRAÎNAMIENTO A VITESSE VARIABLE, CONSULTE LAS INSTRUCCIONES PARA LA DESCARGA DEL CONDENSADOR. EL NO REALIZAR LO ANTERIORMENTE INDICADO, PODRIA OCASIONAR LA MUERTE O SERIAS LESIONES PERSONALES.

**CAUTION**  
USE COPPER CONDUCTORS ONLY!  
UNIT TERMINALS ARE NOT DESIGNED TO ACCEPT OTHER TYPES OF CONDUCTORS.  
FAILURE TO DO SO MAY CAUSE DAMAGE TO THE EQUIPMENT.

**ATTENTION**  
N'UTILISER QUE DES CONDUCTEURS EN CUIVRE!  
LES TERMINAUX DE L'UNITE NE SONT PAS CONÇUS POUR RECEVOIR D'AUTRES TYPES DE CONDUCTEURS.  
L'USAGE D'AUTRES TYPES DE CONDUCTEURS ENDOUAGERAIT L'EQUIPEMENT.

**PRECAUCIÓN**  
¡UTILICE ÚNICAMENTE CONDUCTORES DE COBRE!  
LAS TERMINALES DE LA UNIDAD NO ESTÁN ENFERMADAS PARA ACEPTAR OTROS TIPOS DE CONDUCTORES.  
SI NO LO HACE, PUEDE OCASIONAR DAÑO AL EQUIPO.

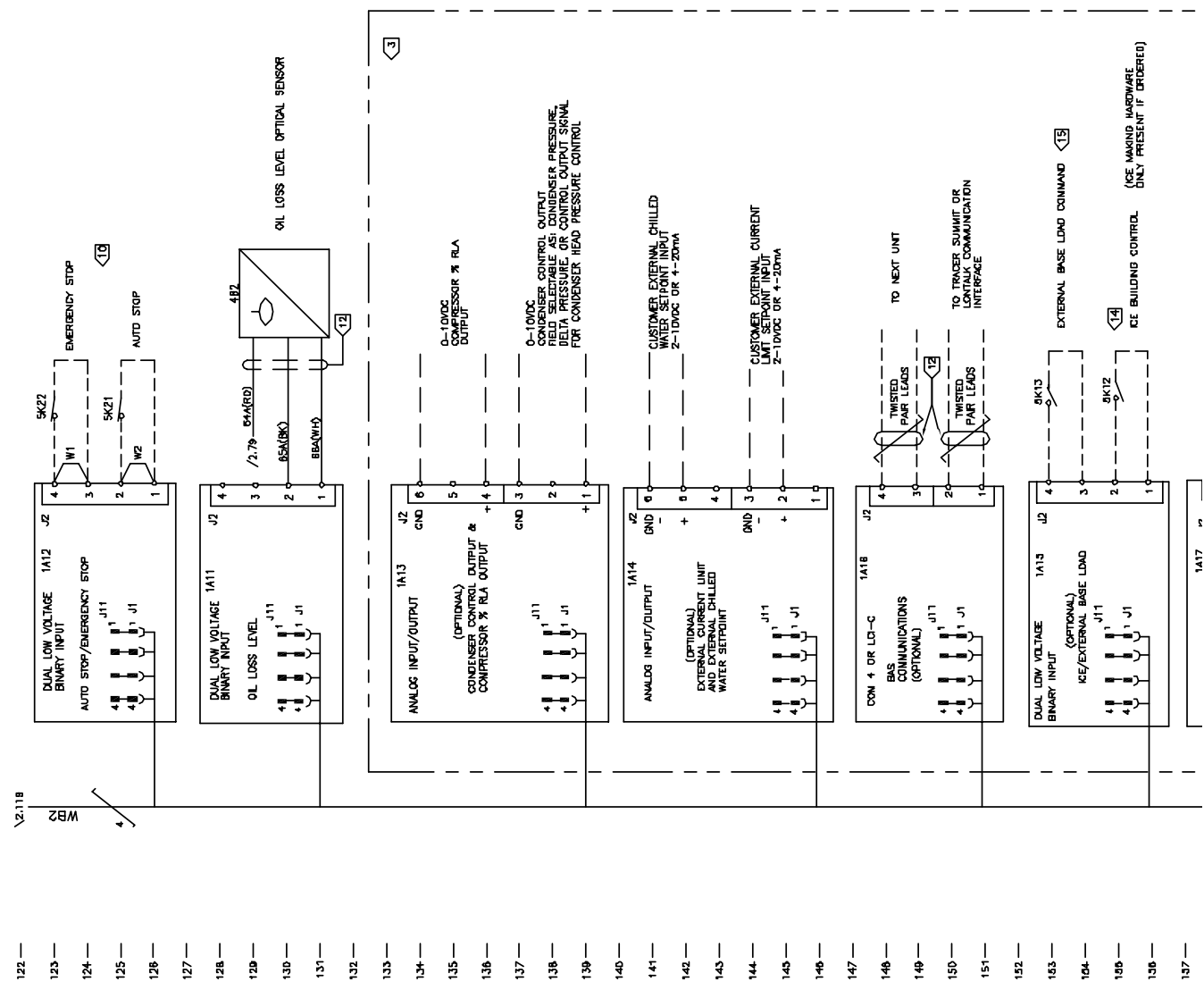

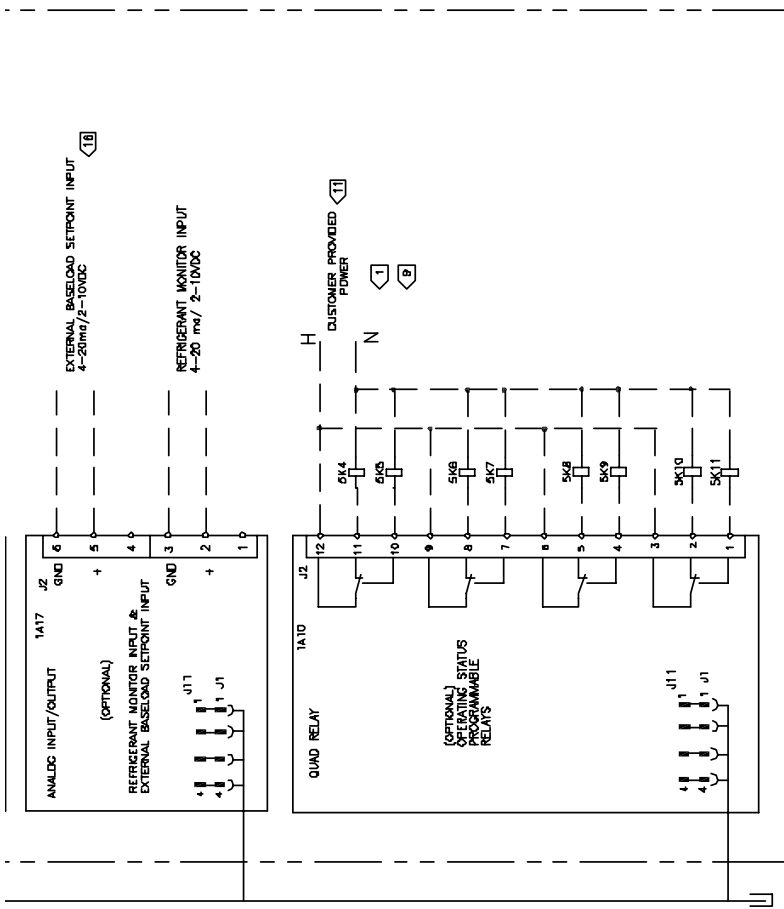

- 157 —
- 158 —
- 159 —
- 160 —
- 161 —
- 162 —
- 163 —
- 164 —
- 165 —
- 166 —
- 167 —
- 168 —
- 169 —
- 170 —
- 171 —
- 172 —
- 173 —
- 174 —
- 175 —
- 176 —
- 177 —
- 178 —
- 179 —
- 180 —

**HAZARDOUS VOLTAGE!**  
DISCONNECT ALL ELECTRIC POWER FROM THE UNIT BEFORE ATTEMPTING TO FOLLOW LOCK OUT AND TAG PROCEDURES BEFORE SERVICING. INSURE THAT ALL MOTOR CAPACITORS HAVE DISCHARGED STORED VOLTAGE. UNITS WITH VARIABLE SPEED DRIVES PERFORM A DISCHARGE RULING TO DO THE ABOVE BEFORE SERVICING COULD RESULT IN DEATH OR SERIOUS INJURY.

**AVERTISSEMENT**  
TENSION DANGEREUSE!  
COUPER TOUTES LES TENSIONS ET DIVAIR LES SECTIONNEURS A DISTANCE, PUIS SUIVRE LES PROCEDURES DE VERROUILLAGE ET DES ETIQUETTES AVANT TOUTE INTERVENTION. VERIFIER QUE TOUS LES CONDENSATEURS DES UNITES SONT DECHARGES. DANS LE CAS D'UNITES A COMPORTANT DES ENTRAINEMENTS A VITESSE VARIABLE, SE REPORTER AUX INSTRUCTIONS DE L'ENTRAIEMENT POUR DECHARGER LES CONDENSATEURS.

**ADVERTENCIA**  
VOLTAJE PELIGROSO!  
DESCONECTE TODA LA ENERGIA ELECTRICA INCLUIDO LAS DESCONEXIONES REMOTAS Y SIGA LOS PROCEDIMIENTOS DE CIERRE Y ETIQUETADO ANTES DE PROCEDER AL SERVICIO. ASEGURESE DE QUITAR TODOS LOS CONDENSADORES DE CUALQUIER UNIDAD DESMONTANDO EL VOLTAJE ALMACENADO. PARA LAS UNIDADES CON EJE DE DIRECCION DE VELOCIDAD VARIABLE, CONSULTE LAS INSTRUCCIONES PARA LA DESCARGA DEL CONDENSADOR.

**CAUTION**  
USE COPPER CONDUCTORS ONLY. UNIT TERMINALS ARE NOT DESIGNED TO ACCEPT OTHER TYPES OF CONDUCTORS. FAILURE TO DO SO MAY CAUSE DAMAGE TO THE EQUIPMENT.

**ATTENTION**  
N'UTILISER QUE DES CONDUCTEURS EN CUIVRE! LES BORNES DE L'UNITE NE SONT PAS CONÇUES POUR RECEVOIR D'AUTRES TYPES DE CONDUCTEURS. L'UTILISATION DE TOUT AUTRE CONDUCTEUR PEUT ENDOMMAGER L'EQUIPEMENT.

**PRECAUCIÓN**  
¡UTILICE ÚNICAMENTE CONDUCTORES DE COBRE! LAS TERMINALES DE LA UNIDAD NO ESTÁN DISEÑADAS PARA ACEPTAR OTROS TIPOS DE CONDUCTORES. SI NO LO HACE, PUEDE OCASIONAR DAÑO AL EQUIPO.

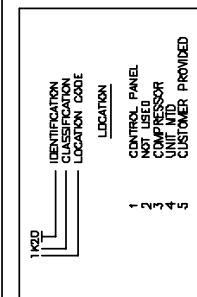

COLOR CODE	IDENTIFICATION
BK	BLACK
BRN	BROWN
BLU	BLUE
GRY	GRAY
RD	RED
WH	WHITE
GRN	GREEN
OR	ORANGE
YL	YELLOW

TRAPE WIRING	CUSTOMER WIRING	OPTIONS
---	---	---
---	---	---
---	---	---

LINE #	ITEM	DESCRIPTION
47	1A1	DYNA VIEW DISPLAY AND INTERFACE
56	1A2	POWER SUPPLY MODULE
66	1A3	STARTER MODULE
86	1A4	HIGH PRESSURE CUTOFF SWITCH
91	1A5	SLIDE VALVE UNLOAD AND LDAOI CONTROL SOLENOID VALVE
96	1A6	OIL RETURN GAS PUMP DRAIN AND FILL SOLENOID VALVE
108	1A7	CONDENSER AND CHILLED WATER FLOW SWITCH INTERLOCKS
101	1A8	ICE BUILDING STATUS OUTPUT AND MASTER OIL LINE SOLENOID VALVE
113	1A9	CONDENSER AND CHILLED WATER PUMP STARTER
164	1A10	OPERATING STATUS PROGRAMMABLE RELAYS
128	1A11	OIL LOSS LEVEL SENSOR AND LAUNDED INPUTS
123	1A12	EXTERNAL AUTO/STOP AND EMERGENCY STOP INPUT
134	1A13	CONDENSER CONTROL AND % RLA OUTPUT
141	1A14	EXTERNAL CURRENT UNIT AND CHILLED WATER
152	1A15	ICE BUILDING CONTROL AND EXTERNAL BASE LOADING COMMAND
147	1A18	QIMM 4 OR LCI-C (COMM 5)
167	1A17	REFRIGERANT MONITOR INPUT AND EXTERNAL BASE LOADING SETPOINT
73	1K1	START CONTACTOR
78	1K2	RUN CONTACTOR
70	1K3	SHUTTING CONTACTOR
82	1K4	TRANSITION CONTACTOR
4	101	MAIN CIRCUIT BREAKER
22	1E1, 1E2, 1E3	PRIMARY FUSES - DEF. LOAD
4	1E4	SECONDARY FUSE - 15A
44	1E5, 1E6	SECONDARY FUSES 27V
4	1E10	DISCONNECT SWITCH
20, 35, 38	1R1-3	TRANSITION RESISTOR
39	1T1	TRANSFORMER
12, 14, 18	1T2-1, 2, 3	CURRENT TRANSFORMERS
52	1T5-1, 2, 3	UNDER OIL VOLUME TRANSFORMERS
4	1X1	TERMINAL BLOCK
27, 28, 29	1X3	UNDER DIER VOLTAGE TERMINAL BLOCK
108	1X5	CONTROL TERMINAL BLOCK 715V
	1X6	FIELD FLOW SWITCH TERMINAL BLOCK
82	3Y1	LOAD SOLENOID VALVE
84	3Y2	UNLOAD SOLENOID VALVE
32	3M1	COMPRESSOR MOTOR
63, 64	4E1-2	DIL PUMP HEATERS
97	4Y1	FLL SOLENOID VALVE
99	4Y2	DRAIN SOLENOID VALVE
65	4Y3	MASTER OIL LINE SOLENOID
129	4B2	OIL LOSS LEVEL SWITCH
40	4B5	EVAPORATOR REFRIGERANT LIQUID LEVEL SENSOR
48	4B20	EVAPORATOR ENTERING WATER TEMP. SENSOR
48	4B21	EVAPORATOR LEAVING WATER TEMP. SENSOR
50	4B22	CONDENSER ENTERING WATER TEMP. SENSOR
52	4B23	CONDENSER LEAVING WATER TEMP. SENSOR
54	4B24	OIL PRESSURE TRANSDUCER
40	4B25	EVAPORATOR REFRIGERANT PRESSURE TRANSDUCER
42	4B26	CONDENSER REFRIGERANT PRESSURE TRANSDUCER
44	4B27	COMPRESSOR DISCHARGE TEMP. SENSOR
66	4B29	HIGH PRESSURE OUTPUT SWITCH
44, 42	4T0-21	DUAL PORT EXV ACTUATOR
62	4B28	OUTDOOR AIR TEMP. SENSOR
115	5K1	CHILLED WATER PUMP STARTER
118	5K2	CONDENSER WATER PUMP STARTER
109-176	5K4-11	UNIT STATUS RELAYS
165	5K12	ICE BUILDING CONTROL

TABLE 1



8Z	8Z65	UNLUCKY AIR HAMP - HANSUK
115	8K1	CHILLED WATER PUMP STARTER
118	8K2	CONDENSER WATER PUMP STARTER
100-176	8K4-11	DAIRY STATUS RELAYS
165	8K12	ICE BUILDUP CONTROL
163	8K13	EXTERNAL BASE LOAD EMBLE
108	8K20	ICE BUILDING STATUS
123	8K22	EXTERNAL EMERGENCY STOP
108	8K21	EXTERNAL AUTO STOP
108	8S1	CHILLED WATER FLOW SWITCH
11D	8S2	CONDENSER WATER FLOW SWITCH

NOTE6:

- 1 CLASS 1 FIELD WIRE MODULE
- 2 CLASS 1 FIELD WIRING INSULATION RATING IS REQUIRED TO BE EQUAL TO OR GREATER THAN THE EQUIPMENT SUPPLY VOLTAGE RATING.  
CLASS 2 FIELD WIRE INSULATION TO BE RATED AT 300V MINIMUM.
- 3 OPTIONAL MODULES. REFER TO FIELD WIRING DIAGRAM FOR SUGGESTED WIRING.

6 TRANSITION RESISTORS SHOWN MAY BE COMBINED OF ONE OR TWO RESISTORS, DEPENDING ON RLA RATING OF COMPRESSOR. REFER TO TABLE 1 FOR RESISTOR CONFIGURATION.

7 OPTIONAL GROUND FAULT CIRCUIT BREAKER.

8 SEE INSET "A" FOR WIRING OF 1F1, 1F2 WHEN UNDER/OVER VOLTAGE OPTION IS NOT USED.

9 FIELD ASSIGNED PROGRAMMABLE RELAYS.

10 AUTO/STOP, EMERGENCY STOP THE CONTACTS ARE JUMPED AT THE FACTORY BY JUMPEES W1 & W2 TO ENABLE UNIT OPERATION. IF REMOTE CONTROL IS DESIRED REMOVE THE JUMPEES AND CONNECT TO THE DESIRED CONTROL CIRCUIT.

11 RELAY AT 120VAC: 7.2 AMPS RESISTIVE, 2.88 AMPS PILOT DUTY, 1/3 HP, 7.2 FLA AT 240VAC; 5 AMPS GENERAL PURPOSE.

12 IF SHIELD IS PRESENT, DO NOT WIRE SHIELD TO GROUND IN CONTROL PANEL. IF USED, SHIELD IS TO BE GROUNDED EXTERNALLY TO CONTROL PANEL. REFERENCE FIELD WIRING DIAGRAM FOR RECOMMENDED WIRE TYPE.

13 RELAY ENERGIZED WHILE MAKING ICE.

14 CONTACT CLOSURE ENABLES ICE MAKING.

15 CLOSED CONTACT COMMANDS BASE LOADING OPERATION.

16 ACTUAL BASE LOADING SETPOINT USED IS SETABLE AT FRONT PANEL. REFER TO 10M FOR DETAILS.

TABLE 1

TRANSITION RESISTOR CONFIGURATION		
VOLTS	RLA	CONFIGURATION
200	477-606	6WW
	607-779	6WW
230	399-476	6WW
	477-606	6WW
	607-779	3EW
346-480	0-277	6WW
	278-364	6WW
	365-398	3EW
	399-476	3EW
	477-606	3EW
550-600	0-277	6WW
	278-364	3EW
	399-476	3EW

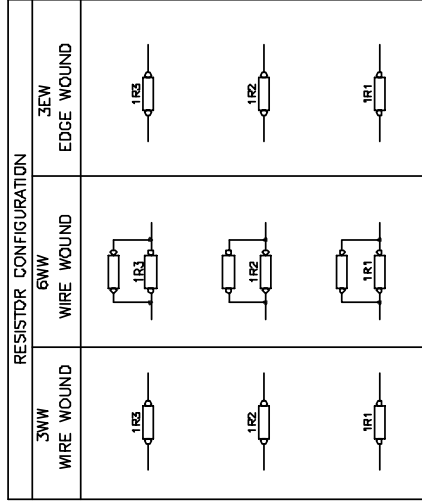

REVISIONS  
REV. NO. DATE  
REASON FOR CHANGE  
REV. NO. DATE  
REASON FOR CHANGE

**WARNING**  
HAZARDOUS VOLTAGE!  
DISCONNECT ALL ELECTRIC POWER BEFORE SERVICING. CAPACITORS HAVE DISCHARGED VOLTAGE STORED IN THEM. ALWAYS DISCHARGE CAPACITORS BEFORE SERVICING.  
FAILURE TO DO THE ABOVE BEFORE SERVICING COULD RESULT IN DEATH OR SERIOUS INJURY.

**AVERTISSEMENT**  
TENSION DANGEREUSE!  
COUPER TOUS LES TENSIONS ET SERVICER AVANT DE COMMENCER. LES CONDENSATEURS ONT DES TENSIONS STOCKEES EN EUX. TOUJOURS DECHARGER LES CONDENSATEURS AVANT DE SERVICER.  
L'EGALISATION DES TENSIONS AVANT DE COMMENCER LE TRAVAIL PEUT RESULTER EN DECES OU EN BLESSURES GRAVES.

**ADVERTENCIA**  
MOLTAJE PELIGROSO!  
DESCONECTE TODA LA ENERGIA ELECTRICA ANTES DE SERVICIAR. LOS CONDENSADORES TIENEN CARGA ALMACENADA EN ELLOS. SIEMPRE DESCARGUE LOS CONDENSADORES ANTES DE SERVICIAR.  
EL NO REALIZAR LO ANTERIORMENTE INDICADO PODRIA OCASIONAR LA MUERTE O SERIAS LESIONES PERSONALES.

**CAUTION**  
EVACUATING REFRIGERANT SYSTEM INCLUDING REMOTE DISCONNECTS PRIOR TO EVACUATING REFRIGERANT SYSTEM POWER SHALL NOT BE APPLIED TO CHILLER WHILE REFRIGERANT SYSTEM IS IN A VACUUM  
Failure to disconnect all electrical power prior to evacuating refrigerant system, or application of power while refrigerant system is in a vacuum, may cause damage due to the nature of the solid state starter.

**CAUTION**  
USE COPPER CONDUCTORS ONLY!  
UNIT TERMINALS ARE NOT DESIGNED TO ACCEPT OTHER TYPES OF CONDUCTORS.  
FAILURE TO DO SO MAY CAUSE DAMAGE TO THE EQUIPMENT.

**PRECAUCIÓN**  
N'UTILISER QUE DES CONDUCTEURS EN CUIVRE!  
LES BORNES DE L'UNITÉ NE SONT PAS CONÇUES POUR RECEVOIR D'AUTRES TYPES DE CONDUCTEURS.  
L'UTILISATION DE TOUT AUTRE CONDUCTEUR PEUT ENDOMMAGER L'EQUIPEMENT.

**ATTENTION**  
UTILICE ÚNICAMENTE CONDUCTORES DE COBRE!  
LAS TERMINALES DE LA UNIDAD NO ESTÁN DISEÑADAS PARA ACEPTAR OTROS TIPOS DE CONDUCTORES.  
SI NO LO HACE, PUEDE OCASIONAR DAÑO AL EQUIPO.

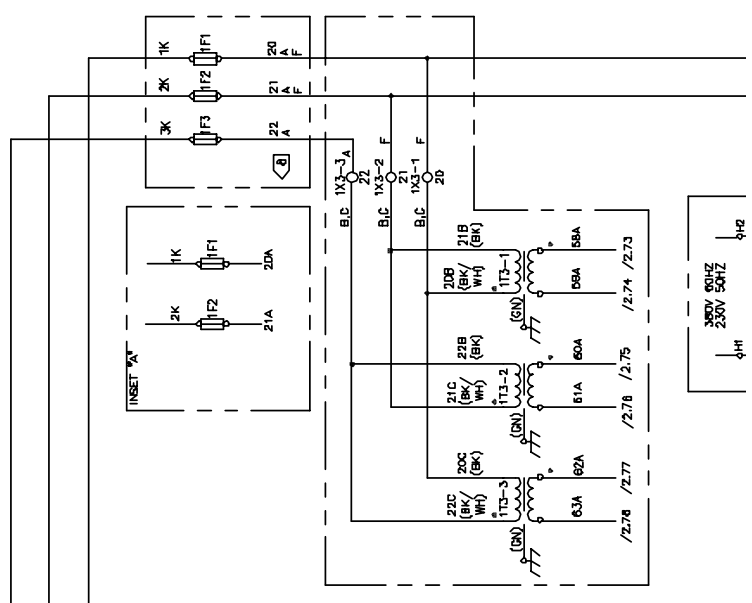
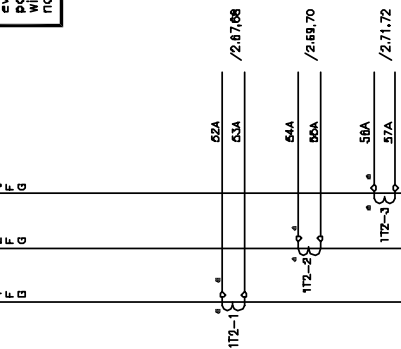
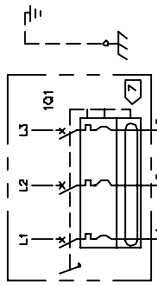

- 1 —
- 2 —
- 3 —
- 4 —
- 5 —
- 6 —
- 7 —
- 8 —
- 9 —
- 10 —
- 11 —
- 12 —
- 13 —
- 14 —
- 15 —
- 16 —
- 17 —
- 18 —
- 19 —
- 20 —
- 21 —
- 22 —
- 23 —
- 24 —
- 25 —
- 26 —
- 27 —
- 28 —
- 29 —
- 30 —
- 31 —
- 32 —
- 33 —
- 34 —
- 35 —
- 36 —
- 37 —

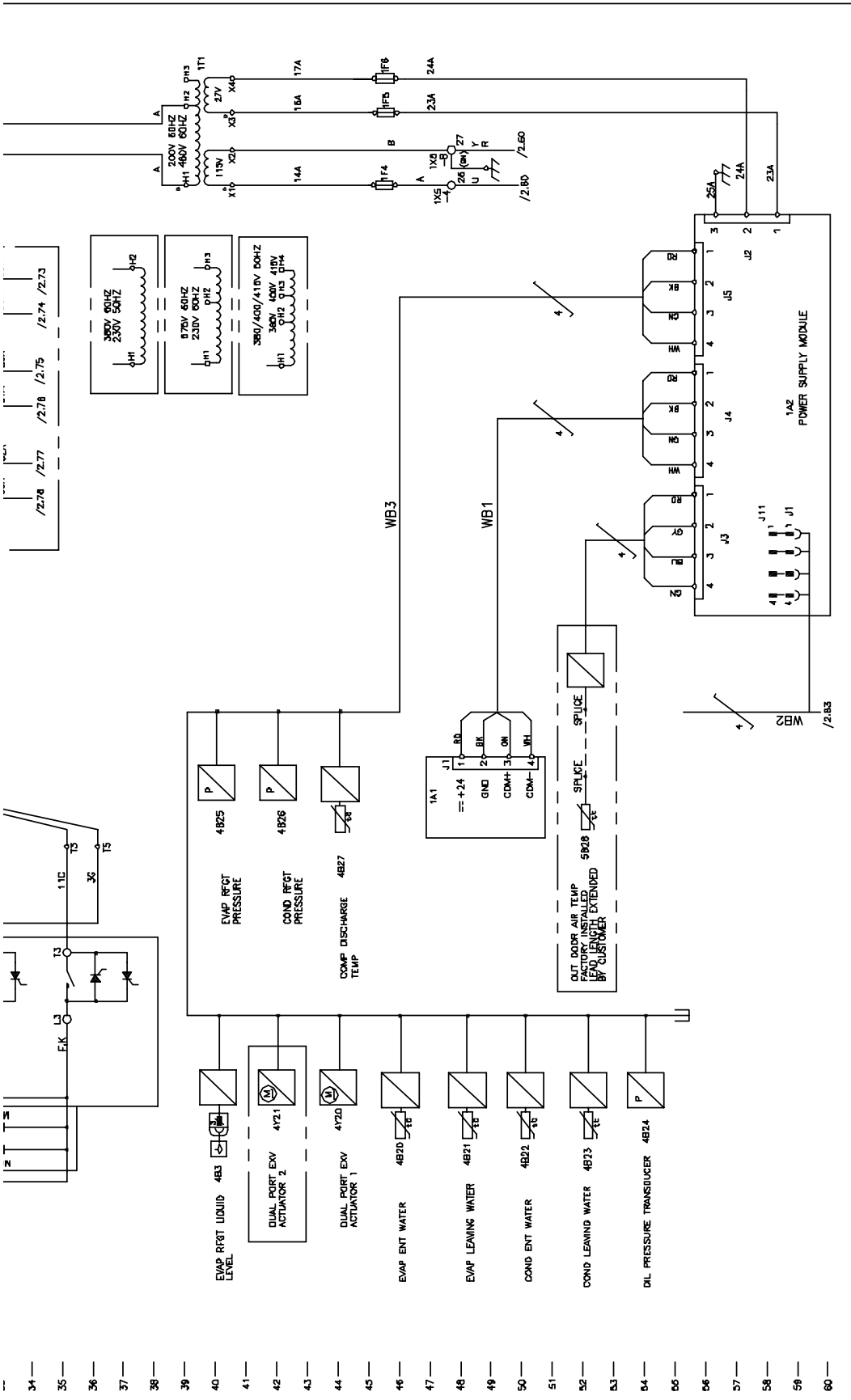

**CAUTION**  
USE COPPER CONDUCTORS ONLY.  
UNIT TERMINALS ARE NOT DESIGNED TO ACCEPT  
OTHER TYPES OF CONDUCTORS.  
FAILURE TO DO SO MAY CAUSE DAMAGE TO THE  
EQUIPMENT.

**ATTENTION**  
N'UTILISER QUE DES CONDUCTEURS EN CUIVRE!  
LES BORNES DE L'UNITÉ NE SONT PAS CONÇUES  
POUR RECEVOIR D'AUTRES TYPES DE CONDUCTEURS.  
L'UTILISATION DE TOUT AUTRE CONDUCTEUR PEUT  
ENDOMMAGER L'ÉQUIPEMENT.

**PRECAUCIÓN**  
UTILICE ÚNICAMENTE CONDUCTORES DE COBRE!  
LAS TERMINALES DE LA UNIDAD NO ESTÁN DISEÑADAS  
PARA ACEPTAR OTROS TIPOS DE CONDUCTORES.  
SI NO LO HACE, PUEDE OCASIONAR DAÑO AL EQUIPO.

**WARNING**  
HAZARDOUS VOLTAGE!  
DISCONNECT ALL ELECTRIC POWER  
INCLUDING REMOTE DISCONNECTS AND  
FOLLOW LOCK-OUT AND TAG-OUT PROCEDURES  
BEFORE WORKING ON THIS EQUIPMENT.  
MOTOR CAPACITORS HAVE DISCHARGED  
STORED VOLTAGE. UNITS WITH VARIABLE  
SPEED DRIVE REFER TO DRIVE  
INSTRUCTIONS FOR CAPACITOR DISCHARGE.  
FAILURE TO DO THE ABOVE BEFORE  
SERVICING COULD RESULT IN DEATH OR  
SERIOUS INJURY.

**AVERTISSEMENT**  
TENSION DANGEREUSE!  
DÉBRANCHER TOUS LES POUVOIRS ÉLECTRIQUES  
Y COMPRIS LES DÉBRANCHEMENTS À DISTANCE  
AVANT DE TRAVAILLER SUR CE MATÉRIEL.  
LES CONDENSATEURS DE MOTEUR ONT DES  
CHARGES ÉLECTRIQUES STOCKÉES. LES UNITÉS À  
VITESSE VARIABLE SE RÉFÈRENT AUX  
INSTRUCTIONS POUR LA DÉCHARGE DES  
CONDENSATEURS. LE NON-RESPECT DE CES  
RÈGLES PEUT CAUSER LA MORT OU DE  
GRAVES BLESSURES.

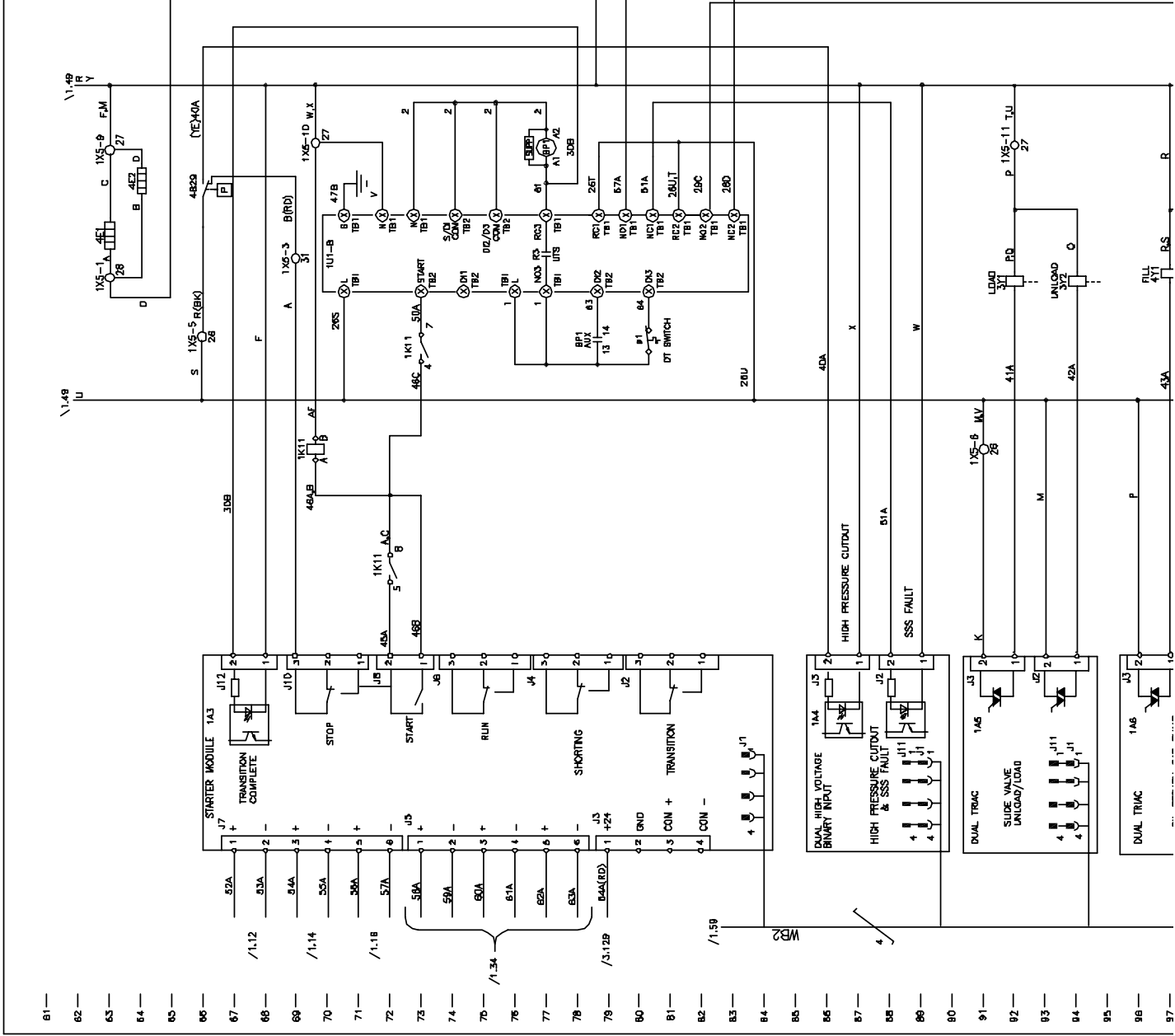

**WARNING**

HAZARDOUS VOLTAGE!  
DISCONNECT ALL ELECTRIC POWER INCLUDING REMOTE DISCONNECTS AND LOCK OUT AND TAG OUT ALL ENERGIES BEFORE SERVICING. MOTOR CAPACITORS HAVE DISCHARGED STORED VOLTAGE. UNITS WITH VARIABLE SPEED DRIVE, REFER TO DRIVE INSTRUCTIONS FOR CAPACITOR DISCHARGE. FAILURE TO DO THE ABOVE BEFORE SERVICING COULD RESULT IN DEATH OR SERIOUS INJURY.

**AVERTISSEMENT**

TENSION DANGEREUSE!  
COUPER TOUTES LES TENSIONS ET VERIFIER LA PRESENCE DE LA TENSION. PLUS SAVOIR LES PROCEDURES DE VERROUILLAGE ET DES ETIQUETTES DE TOUTE INTERVENTION. VERIFIER QUE TOUTS LES CONDENSATEURS DES MOTEURS SONT DECHARGES. LES UNITS A VITESSE VARIABLE, SE REFERER AUX INSTRUCTIONS DE L'ENTRAÎNEMENT POUR DECHARGER LES CONDENSATEURS. NE PAS RESPECTER CES MESURES DE PRECAUTION PEUT ENTRAINER DES BLESSURES GRAVES POUVANT ETRE MORTELLES.

**ADVERTENCIA**

VOLTAJE PELIGROSO!  
DESCONECTE TODA LA ENERGIA ELECTRICA, INCLUIDAS LAS DESCONECTAS REMOTAS, Y SIEMPRE PROTEGIENDO DE SERVICIO Y ETIQUETADO ANTES DE PROCEDER AL SERVICIO. ASEGURESE DE QUE TODOS LOS CAPACITORES DEL MOTOR HAYAN SIDO DESCARGADOS. LAS UNIDADES CON VELOCIDAD VARIABLE, CONSULTE LAS INSTRUCCIONES PARA LA DESCARGA DEL CONDENSADOR. EL NO REALIZAR LO ANTERIORMENTE INDICADO, PODRIA OCASIONAR LA MUERTE O SERIAS LESIONES PERSONALES.

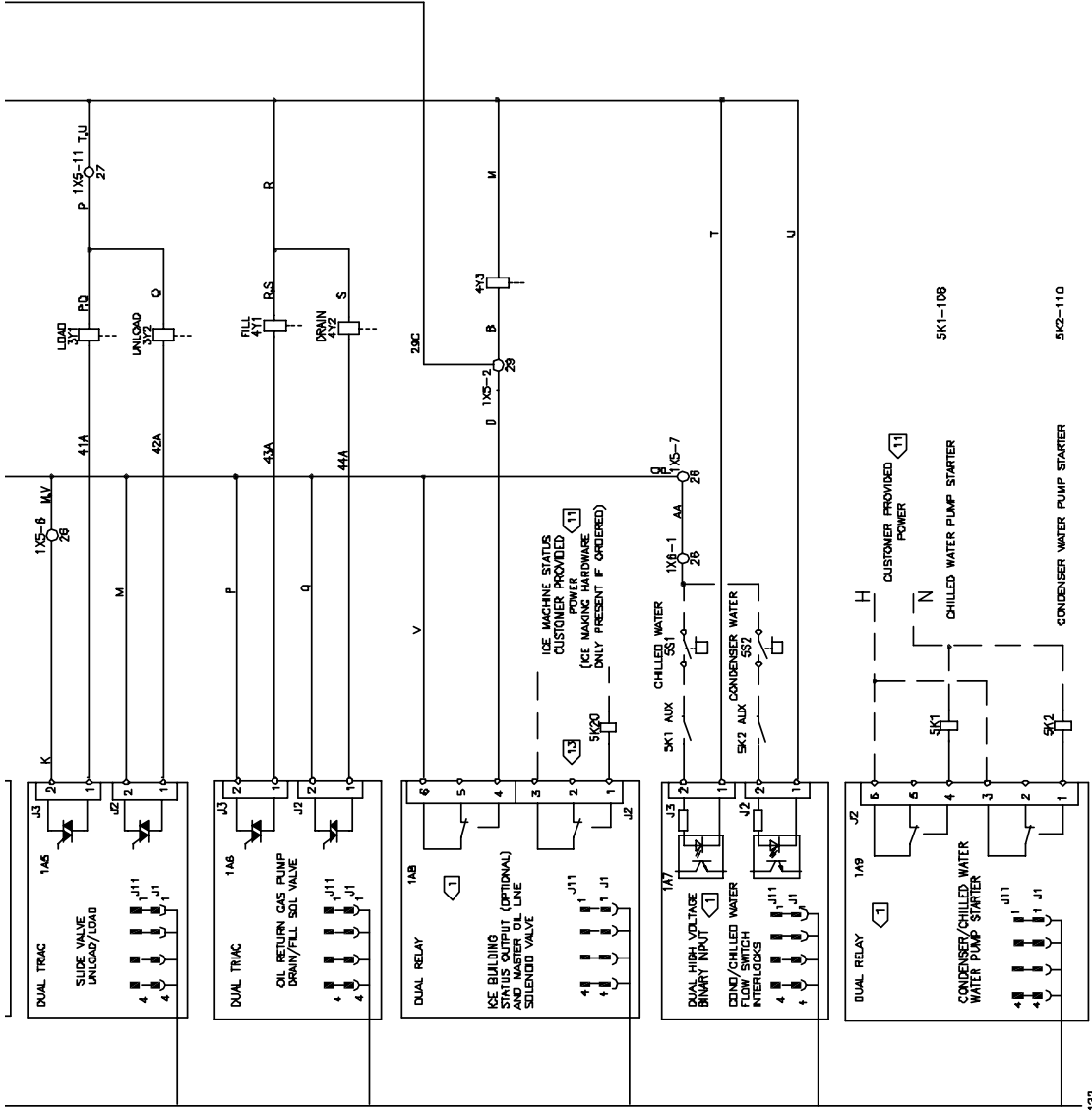

/3.122

- 90 —
- 91 —
- 92 —
- 93 —
- 94 —
- 95 —
- 96 —
- 97 —
- 98 —
- 99 —
- 100 —
- 101 —
- 102 —
- 103 —
- 104 —
- 105 —
- 106 —
- 107 —
- 108 —
- 109 —
- 110 —
- 111 —
- 112 —
- 113 —
- 114 —
- 115 —
- 116 —
- 117 —
- 118 —
- 119 —
- 120 —

**WARNING**  
 HAZARDOUS VOLTAGE!  
 DISCONNECT ALL ELECTRIC POWER  
 BEFORE SERVICING. FOLLOW THE  
 FOLLOWING LOCK OUT AND TAG PROCEDURES  
 BEFORE SERVICING. INSURE THAT ALL  
 MOTOR CAPACITORS HAVE DISCHARGED  
 STORED VOLTAGE. UNITS WITH VARIABLE  
 SPEED DRIVE MUST FOLLOW THE  
 INSTRUCTIONS FOR CAPACITOR DISCHARGE.  
 FAILURE TO DO THE ABOVE BEFORE  
 SERVICING COULD RESULT IN DEATH OR  
 SERIOUS INJURY.

**AVERTISSEMENT**  
 TENSION DANGEREUSE!  
 COUPER TOUTES LES TENSIONS ET  
 OUVRIER LES SECTIONNEURS A DISTANCE.  
 PUIS SUIVRE LES PROCEDURES DE  
 VERROUILLAGE ET DES ETIQUETTES AVANT  
 LES TRAVAUX. ASSUREZ-VOUS QUE TOUS  
 LES CONDENSATEURS DES UNITES A  
 DECHARGES, DANS LE CAS D'UNITES  
 COMPORTANT DES ENTRAINEMENTS A  
 VITESSE VARIABLE, SE REPORTER AUX  
 INSTRUCTIONS DE SERVICE POUR  
 DECHARGER LES CONDENSATEURS.  
 NE PAS SERVICER LES MESURES DE  
 PRECAUTION PEUT PROVOQUER DES  
 BLESSURES GRAVES POUVANT ETRE  
 MORTELLES.

**ADVERTENCIA**  
 VOLTAJE PELIGROSO!  
 DESCONECTE TODA LA ENERGIA ELECTRICA,  
 INCLUIDO LAS DESCONECCIONES REMOTAS Y  
 SIGA LOS PROCEDIMIENTOS DE CERRE Y  
 ETIQUETADO ANTES DE SERVICIAR.  
 SERVICIAR ASEGURADO DE QUE TODOS  
 LOS CAPACITORES DEL MOTOR HAYAN  
 DESCARGADO EL VOLTAJE ALMACENADO.  
 PARA LAS UNIDADES CON EJE DE  
 DIRECCION DE VELOCIDAD VARIABLE,  
 LEER LAS INSTRUCCIONES PARA LA  
 DESCARGA DEL CONDENSADOR.  
 EL NO REALIZAR LO ANTERIORMENTE  
 INDICADO, PODRIA OCASIONAR LA MUERTE  
 O SERIAS LESIONES PERSONALES.

**CAUTION**  
 USE COPPER CONDUCTORS ONLY!  
 UNIT TERMINALS ARE NOT DESIGNED TO ACCEPT  
 OTHER TYPES OF CONDUCTORS.  
 FAILURE TO DO SO MAY CAUSE DAMAGE TO THE  
 EQUIPMENT.

**ATTENTION**  
 N'UTILISER QUE DES CONDUCTEURS EN CUIVRE!  
 LES BORNES DE L'UNITE NE SONT PAS CONÇUES  
 POUR RECEVOIR D'AUTRES TYPES DE CONDUCTEURS.  
 L'UTILISATION DE TOUT AUTRE CONDUCTEUR PEUT  
 ENDOMMAGER L'EQUIPEMENT.

**PRECAUCIÓN**  
 UTILICE ÚNICAMENTE CONDUCTORES DE COBRE!  
 LAS TERMINALES DE LA UNIDAD NO ESTÁN DISEÑADAS  
 PARA ACEPTAR OTROS TIPOS DE CONDUCTORES.  
 SI NO LO HACE, PUEDE OCASIONAR DAÑO AL EQUIPO.

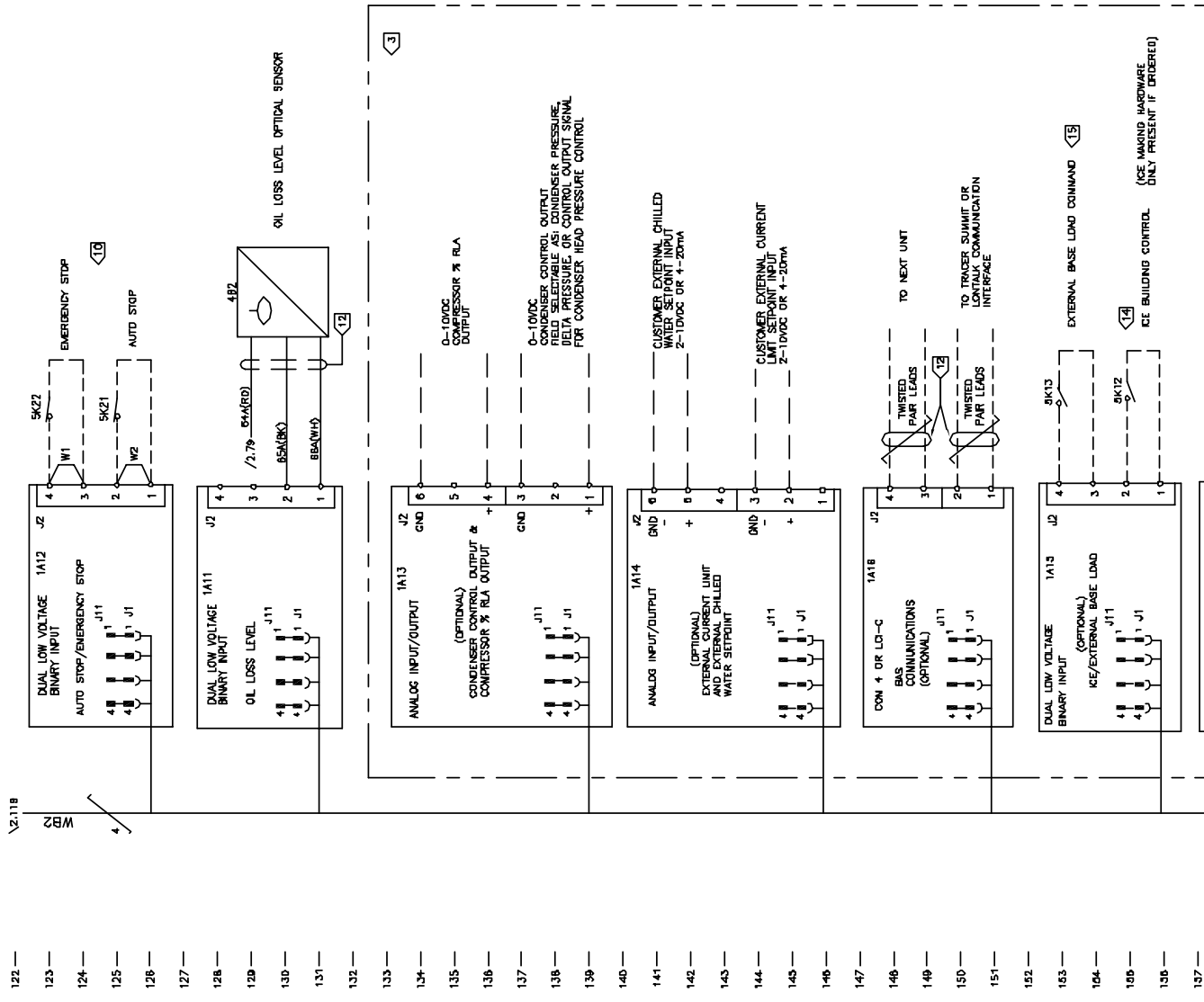

136 —  
 137 —  
 138 —  
 139 —  
 140 —  
 141 —  
 142 —  
 143 —  
 144 —  
 145 —  
 146 —  
 147 —  
 148 —  
 149 —  
 150 —  
 151 —  
 152 —  
 153 —  
 154 —  
 155 —  
 156 —  
 157 —  
 158 —  
 159 —  
 160 —  
 161 —  
 162 —  
 163 —  
 164 —  
 165 —  
 166 —  
 167 —  
 168 —  
 169 —  
 170 —  
 171 —  
 172 —  
 173 —  
 174 —  
 175 —  
 176 —  
 177 —  
 178 —  
 179 —  
 180 —

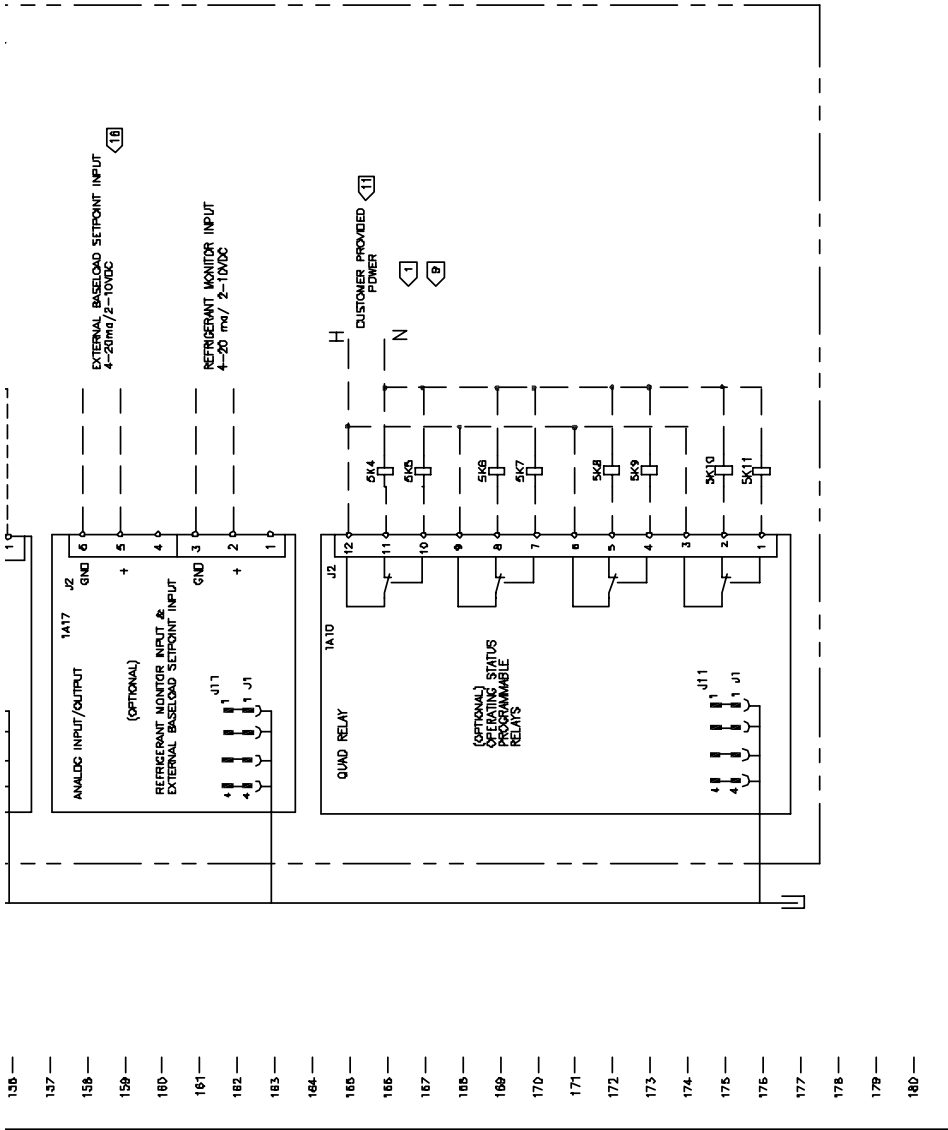

2309-1363 SCHEMATIC WIRING RTHD

REPLACES 2309-1363

REVISION DATE: 11-23-04

REPLACES: 2309-7564

QUALITY TO 2309-7564

SOLID STATE STARTER

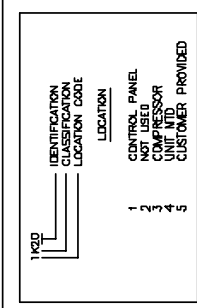

COLOR CODE	IDENTIFICATION CLASSIFICATION
BK	BLACK
BN	BROWN
BU	BLUE
GR	GRAY
RD	RED
WH	WHITE
OR	ORANGE
YL	YELLOW

TERMINAL	DESCRIPTION
1	CONTROL PANEL
2	ICE BUILDING STATUS
3	COMPRESSOR UNIT MTD
4	CUSTOMER PROVIDED
5	CUSTOMER PROVIDED

LINE #	ITEM	DESCRIPTION
47	1A1	DYNA VIEW DISPLAY AND INTERFACE
56	1A2	POWER SUPPLY MODULE
56	1A3	STARTER MODULE
56	1A4	SOLID STATE STARTER FAULT AND HIGH PRESSURE OUTPUT SWITCH
91	1A5	SLIDE VALVE UNLOAD AND LOAD CONTROL SOLENOID VALVE
96	1A6	OIL RETURN GAS PUMP DRAIN AND FILL SOLENOID VALVE
108	1A7	CONDENSER AND CHILLED WATER FLOW SWITCH INTERLOCKS
101	1A8	ICE BUILDING STATUS OUTPUT AND MASTER OIL LINE SOLENOID VALVE
113	1A9	CONDENSER AND CHILLED WATER PUMP STARTER
164	1A10	OPERATING STATUS PROGRAMMABLE RELAYS
128	1A11	OIL LOSS LEVEL SENSOR AND UNLUSED INPUTS
123	1A12	EXTERNAL AUTO/STOP AND EMERGENCY STOP INPUT
134	1A13	CONDENSER CONTROL AND % RLA OUTPUT
141	1A14	EXTERNAL CURRENT LIMIT AND CHILLED WATER
152	1A15	ICE BUILDING CONTROL AND EXTERNAL BASE LOADING COMMAND
147	1A18	COMM 4 OR L2-C (COMM 5)
107	1A17	REFRIGERANT MONITOR INPUT AND EXTERNAL BASE LOADING SETPOINT
4, 8D	101	MAN CIRCUIT BREAKER
23	1E1, 1E2, 1E3	PRIMARY FUSES - DFT, UDWM
44	1F4	SECONDARY FUSE 115V
44	1F5, 1F8	SECONDARY FUSES 27V
39	1T1	TRANSFORMER
12, 14, 16	1T2-1, 2, 3	CURRENT TRANSFORMERS
32	1T5-1, 2, 3	UNDER OVER VOLTAGE TRANSFORMERS
26, 77	1U1	SOLID STATE STARTER
27, 28, 29	1X3	UNDER OVER VOLTAGE TERMINAL BLOCK
1X5	1X5	CONTROL TERMINAL BLOCK 115V
108	1X6	FIELD FLOW SWITCH TERMINAL BLOCK
8D	1X7	CIRCUIT BREAKER SHUNT TRIP TERMINAL BLOCK
82	3Y1	LOAD SOLENOID VALVE
94	3Y2	UNLOAD SOLENOID VALVE
32	3M1	COMPRESSOR MOTOR
63, 64	4E1-2	OIL SUMP HEATERS
97	4Y1	FLL SOLENOID VALVE
90	4Y2	DRAIN SOLENOID VALVE
103	4Y3	MARSHER OIL LINE SOLENOID
129	4B2	OIL LOSS LEVEL SWITCH
40	4B3	EVAPORATOR REFRIGERANT LIQUID LEVEL SENSOR
48	4B7D	EVAPORATOR ENTERING WATER TEMP. SENSOR
48	4B21	EVAPORATOR LEAVING WATER TEMP. SENSOR
8D	4B72	CONDENSER ENTERING WATER TEMP. SENSOR
82	4B23	CONDENSER LEAVING WATER TEMP. SENSOR
54	4B24	OIL PRESSURE TRANSDUCER
40	4B25	EVAPORATOR REFRIGERANT PRESSURE TRANSDUCER
42	4B26	CONDENSER REFRIGERANT PRESSURE TRANSDUCER
44	4B27	COMPRESSOR DISCHARGE TEMP. SENSOR
68	4B7D	HIGH PRESSURE OUTPUT SWITCH
44, 42	4Y20-21	DUAL PORT EXV ACTUATOR
92	8E2B	OUTDOOR AIR TEMP. SENSOR
115	5K1	CHILLED WATER PUMP STARTER
118	5K2	CONDENSER WATER PUMP STARTER
100-176	5K4-11	UNIT STATUS RELAYS
165	5K12	ICE BUILDING CONTROL
163	5K13	EXTERNAL BASE LOAD ENABLE

**WARNING**  
HAZARDOUS VOLTAGE!  
DISCONNECT ALL ELECTRIC POWER FROM THE UNIT BEFORE SERVICING. FOLLOW LOCKOUT AND TAGOUT PROCEDURES BEFORE SERVICING. INSURE THAT ALL MOTOR CAPACITORS HAVE DISCHARGED STORED VOLTAGE. UNITS WITH VARIABLE SPEED DRIVE REFER TO DRIVE INSTRUCTIONS FOR CAPACITOR DISCHARGE PROCEDURES. FAILURE TO FOLLOW THESE SERVICING COULD RESULT IN DEATH OR SERIOUS INJURY.

**AVERTISSEMENT**  
TENSION DANGEREUSE!  
COUPER TOUTES LES TENSIONS ET QU'AVRIL LES SECTIONNEURS A DISTANCE, PLUS SUIVRE LES PROCEDURES DE VERROUILLAGE ET DES ETIQUETTES AVANT TOUTE INTERVENTION. VÉRIFIER QUE TOUS LES CONDENSATEURS AÏR AÏR AÏR SONT DÉCHARGÉS, DANS LE CAS D'UNITÉS COMPORTANT DES ENTRAÎNEMENTS A VITESSE VARIABLE, SE REPORTER AUX INSTRUCTIONS DE L'ENTRAÎNEMENT POUR DÉCHARGER LES CONDENSATEURS. NE PAS RESPECTER CES MESURES DE SÛRETÉ PEUT CAUSER LA MORT OU DES BLESSURES GRAVES POUVANT ÊTRE MORTELLES.

**ADVERTENCIA**  
VOLTAJE PELIGROSO!  
DESCONECTE TODA LA ENERGIA ELECTRICA, INCLUIDO LAS DESCONEXIONES REMOVIAS Y SIGA LOS PROCEDIMIENTOS DE CIERRE Y VERROUILLAJE ANTES DE PROCEDER CON CUALQUIER SERVICIO. VERIFIQUE QUE TODOS LOS CAPACITORES DEL MOTOR HAYAN DESCARGADO EL VOLTAJE ALMACENADO. PARA LAS UNIDADES CON EJE DE DIRECCION DE VELOCIDAD VARIABLE, REVISAR LAS INSTRUCCIONES PARA LA DESCARGA DEL CONDENSADOR. EL NO REALIZAR LO ANTERIORMENTE INDICADO PODRIA OCASIONAR LA MUERTE O SERIAS LESIONES PERSONALES.

**CAUTION**  
USE COPPER CONDUCTORS ONLY!  
UNIT TERMINALS ARE NOT DESIGNED TO ACCEPT OTHER TYPES OF CONDUCTORS.  
FAILURE TO DO SO MAY CAUSE DAMAGE TO THE EQUIPMENT.

**ATTENTION**  
N'UTILISER QUE DES CONDUCTEURS EN CUIVRE!  
LES BORNES DE L'UNITÉ NE SONT PAS CONÇUES POUR RECEVOIR D'AUTRES TYPES DE CONDUCTEURS.  
L'UTILISATION DE TOUT AUTRE CONDUCTEUR PEUT ENDOMMAGER L'ÉQUIPEMENT.

**PRECAUCIÓN**  
UTILICE ÚNICAMENTE CONDUCTORES DE COBRE!  
LAS TERMINALES DE LA UNIDAD NO ESTAN DISEÑADAS PARA ACEPTAR OTROS TIPOS DE CONDUCTORES.  
SI NO LO HACE, PUEDE OCASIONAR DAÑO AL EQUIPO.



02	4823	CONDENSER LEAVING WATER TEMP. SENSOR
54	4824	OIL PRESSURE TRANSDUCER
40	4825	EVAPORATOR REFRIGERANT PRESSURE TRANSDUCER
42	4826	CONDENSER REFRIGERANT PRESSURE TRANSDUCER
44	4827	COMPRESSOR DISCHARGE TEMP. SENSOR
66	4929	HIGH PRESSURE CUTOFF SWITCH
44, 42	4120-21	DUAL PORT EXV ACTUATOR
82	8228	OUTDOOR AIR TEMP. SENSOR
115	SK1	CHILLED WATER PUMP STARTER
118	SK2	CONDENSER WATER PUMP STARTER
108-176	SK4-11	UNIT STATUS RELAYS
165	SK12	ICE BUILDING CONTROL
163	SK13	EXTERNAL BASE LOAD ENABLE
108	SK20	ICE BUILDING STATUS
123	SK22	EXTERNAL EMERGENCY STOP
128	SK21	EXTERNAL AUTO STOP
108	SK1	CHILLED WATER FLOW SWITCH
110	SK2	CONDENSER WATER FLOW SWITCH

NOTES:

- 1 CLASS 1 FIELD WIRE MODULE
- 2 CLASS 1 FIELD WIRING INSULATION RATING IS REQUIRED TO BE EQUAL TO OR GREATER THAN THE EQUIPMENT SUPPLY VOLTAGE RATING.  
CLASS 2 FIELD WIRE INSULATION TO BE RATED AT 300V MINIMUM.
- 3 OPTIONAL MODULES. REFER TO FIELD WIRING DIAGRAM FOR SUGGESTED WIRING.
- 7 OPTIONAL GROUND FAULT CIRCUIT BREAKER.
- 8 SEE INSET "A" FOR WIRING OF 1F1, 1F2 WHEN UNDER/OVER VOLTAGE OPTION IS NOT USED.
- 8 FIELD ASSIGNED PROGRAMMABLE RELAYS.
- 10 AUTO/STOP, EMERGENCY STOP THE CONTACTS ARE JUMPED AT THE FACTORY BY THE WIRING ENGINEER. REMOVE THE JUMPS AND CONNECT TO THE DESIRED CONTROL CIRCUIT.
- 11 RELAY AT 120VAC: 7.2 AMPS RESISTIVE, 2.88 AMPS PILOT DUTY, 1/3 HP, 7.2 FLA AT 240VAC: 5 AMPS GENERAL PURPOSE.
- 12 IF SHIELD IS PRESENT, DO NOT WIRE SHIELD TO GROUND IN CONTROL PANEL. IF USED, SHIELD IS TO BE GROUNDLED EXTERNALLY TO CONTROL PANEL. REFERENCE FIELD WIRING DIAGRAM FOR RECOMMENDED WIRE TYPE.
- 13 RELAY ENERGIZED WHILE MAKING ICE.
- 14 CONTACT CLOSURE ENABLES ICE MAKING.
- 15 CLOSED CONTACT COMMANDS BASE LOADING OPERATION.
- 16 ACTUAL BASE LOADING SETPOINT USED IS SETTABLE AT FRONT PANEL. REFER TO IOM FOR DETAILS.

<b>2309-7564</b> <small>REVISIONS</small> <small>REVISION DATE</small> 9-20-00 <small>BY</small> WFE-DOLLA STARK	<b>2309-7564</b> <b>COMPONENT LOCATION</b> RTHD
---	---

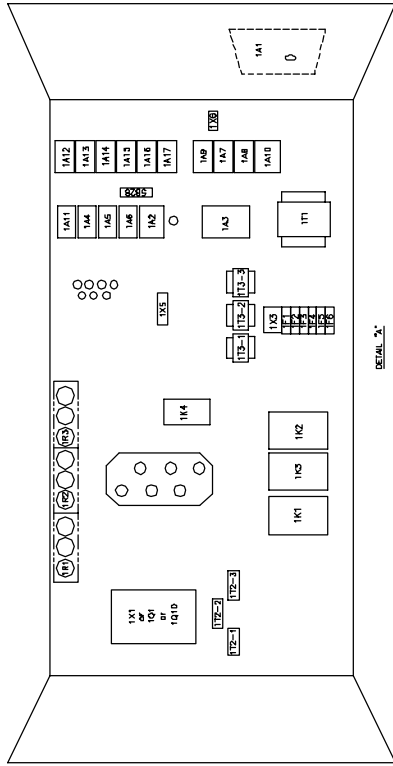

DETAIL "A"

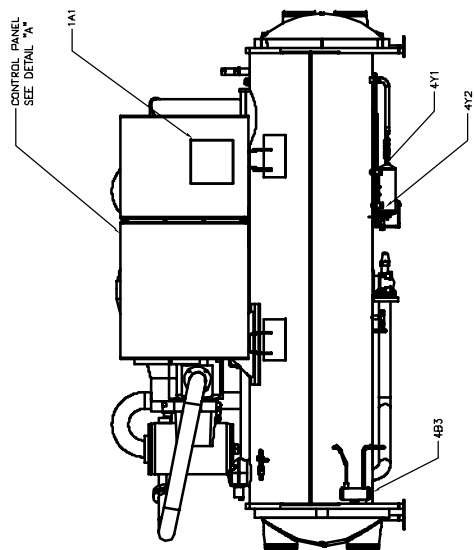
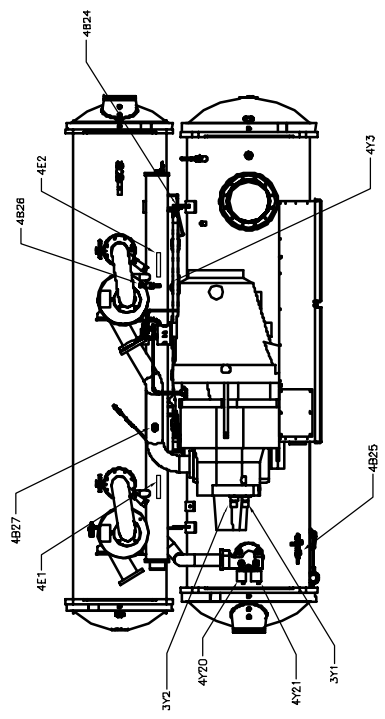
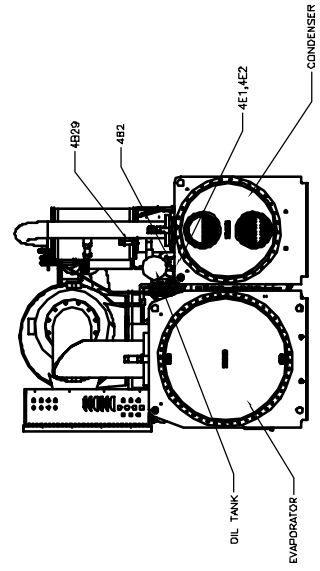

2309-7565	REF
COMPONENT LOCATION	
RTHD	
SOLID STATE STARTER	
GENERAL DIMS P-28-QD	
DRAWING NO.	

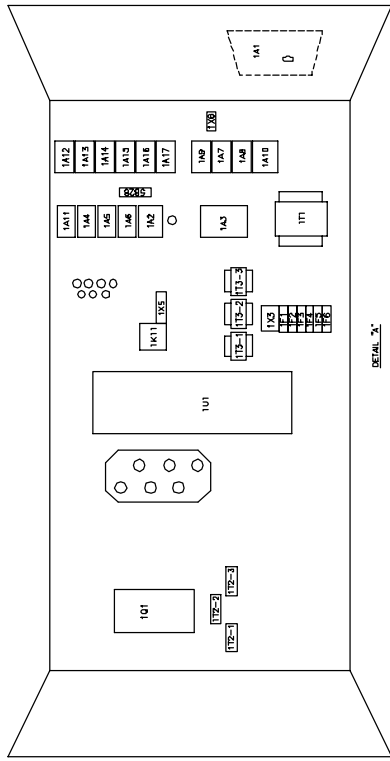

DETAIL "A"

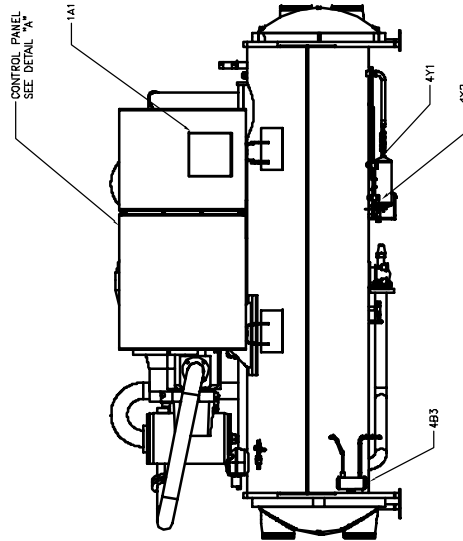
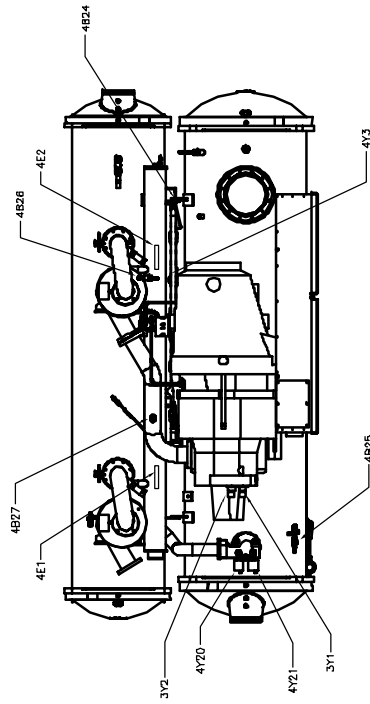
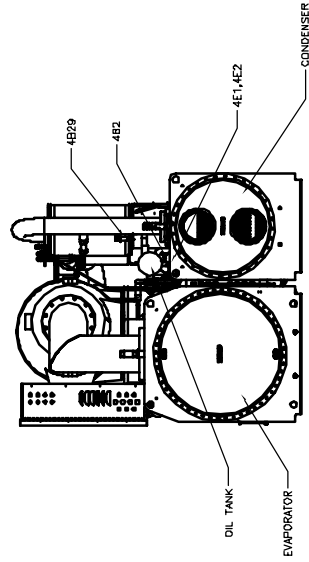

REVISED	BY
2309-4870	D
FIELD WIRING	
RTHD	
THE TRANE COMPANY	
DESIGN DATE	APPROVAL
6-24-83	FIELD WIRING
DRAWN BY	DATE
PBL	3-12-83
SIMILAR TO	

**⚠ WARNING**  
HAZARDOUS VOLTAGE!  
DISCONNECT ALL ELECTRIC POWER INCLUDING REMOTE DISCONNECTS AND REMOTE STOP DEVICES FROM THE UNIT BEFORE SERVICING. INSURE THAT ALL MOTOR CAPACITORS HAVE DISCHARGED TO ZERO VOLTAGE. UNITS WITH VARIABLE FREQUENCY DRIVES MUST FOLLOW THE INSTRUCTIONS FOR CAPACITOR DISCHARGE FAILURE TO DO THE ABOVE BEFORE SERVICING COULD RESULT IN DEATH OR SERIOUS INJURY.

**⚠ AVERTISSEMENT**  
TENSION DANGEREUSE!  
COUPER TOUS LES TENSIONS ET TOUS LES DISPOSITIFS DE DÉCONNEXION À DISTANCE, Y COMPRIS LES DISPOSITIFS DE VERROUILLAGE ET DES ÉTIQUETTES AVANT TOUTE INTERVENTION. VÉRIFIER QUE TOUS LES CONDENSATEURS LES TOUTES VITESSES VARIABLE SE DÉCHARGENT À ZÉRO VOLTAGE. LES UNITÉS À VITESSE VARIABLE SE DÉCHARGENT À ZÉRO VOLTAGE. NE PAS RÉALISER LA RÉPARATION SANS AVOIR DÉCONNECTÉ TOUS LES DISPOSITIFS DE DÉCONNEXION À DISTANCE. LA PRÉCAUTION PEUT ÊTRE ENVIÉE À LA PRÉCAUTION POUR ÉVITER DES BLESSURES GRAVES POUVANT ÊTRE MORTELLES.

**⚠ ADVERTENCIA**  
VOLTAJE PELIGROSO!  
DESCONECTE TODA LA ENERGÍA ELÉCTRICA, INCLUIDOS LOS DISPOSITIVOS DE DESCONEXIÓN A DISTANCIA Y LOS PROCEDIMIENTOS DE CIERRE Y ETIQUETADO ANTES DE PROCEDER AL SERVICIO. ASEGURESE DE QUE TODOS LOS CONDENSADORES DE LOS MOTORES SE DESCARGAN A VOLTAJE ALMACENADO. PARA LAS UNIDADES CON EJE DE DIRECCIÓN DE VELOCIDAD VARIABLE, EL SERVICIO DE LOS CONDENSADORES DE DESCARGA DEBE REALIZARSE ANTES DE LA REPARACIÓN. PARA LA UNIDAD CON MOTOR DE VELOCIDAD VARIABLE, EL NO REALIZAR LO ANTERIORMENTE INDICADO, PODRÍA OCASIONAR LA MUERTE O SERIAS LESIONES PERSONALES.

CUSTOMER PROVIDED CLASS 1 CONTROL WIRING KNOCKOUTS IN RIGHT SIDE OF CONTROL BOX.

TABLE 1	
SELECTION	CIRCUIT BREAKER
0-478	(2) 3/0-250 MCM
477-640	(3) 1/0-500 MCM
641-779	(4) 250-500 MCM
STARTER SIZE	NON-FUSED DISCONNECT SWITCH
207-476	(2) 3/0-250 MCM
500-596	(3) 1/0-500 MCM
779	(4) 250-500 MCM
STARTER SIZE (MFL)	MAIN LUGS ONLY
207-476	(2) 18-100 MCM
500-596	(3) 21-600 MCM

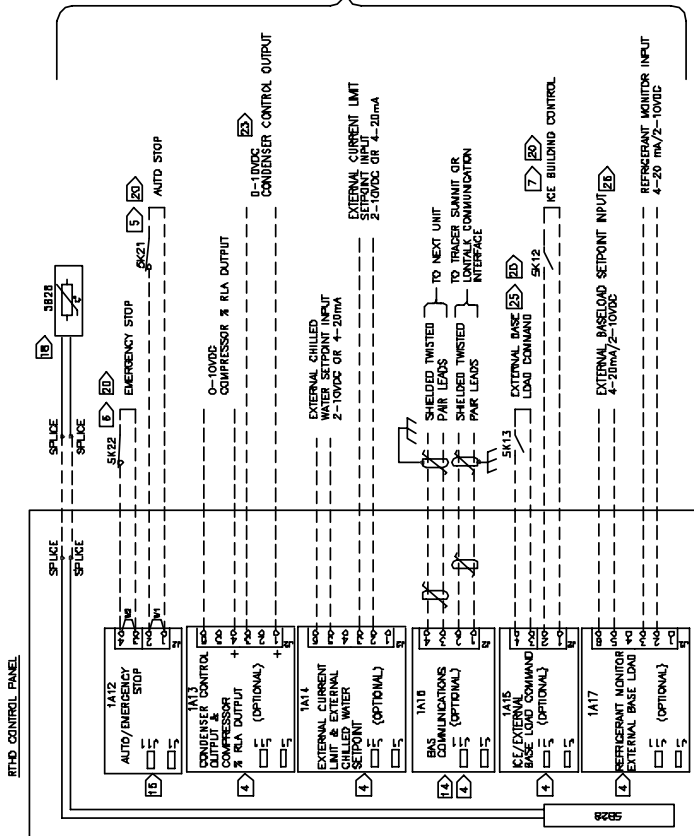

**CAUTION**  
USE COPPER CONDUCTORS ONLY!  
UNIT TERMINALS ARE NOT DESIGNED TO ACCEPT OTHER TYPES OF CONDUCTORS.  
FAILURE TO DO SO MAY CAUSE DAMAGE TO THE EQUIPMENT.

**ATTENTION**  
N'UTILISER QUE DES CONDUCTEURS EN CUIVRE!  
LES BORNES DE L'UNITÉ NE SONT PAS CONÇUES POUR RECEVOIR D'AUTRES TYPES DE CONDUCTEURS.  
L'UTILISATION DE TOUT AUTRE CONDUCTEUR PEUT ENDOMMAGER L'ÉQUIPEMENT.

**PRECAUCIÓN**  
¡UTILICE ÚNICAMENTE CONDUCTORES DE COBRE!  
LAS TERMINALES DE LA UNIDAD NO ESTÁN DISEÑADAS PARA ACEPTAR OTROS TIPOS DE CONDUCTORES.  
SI NO LO HACE, PUEDE DAÑAR O AL EQUIPO.



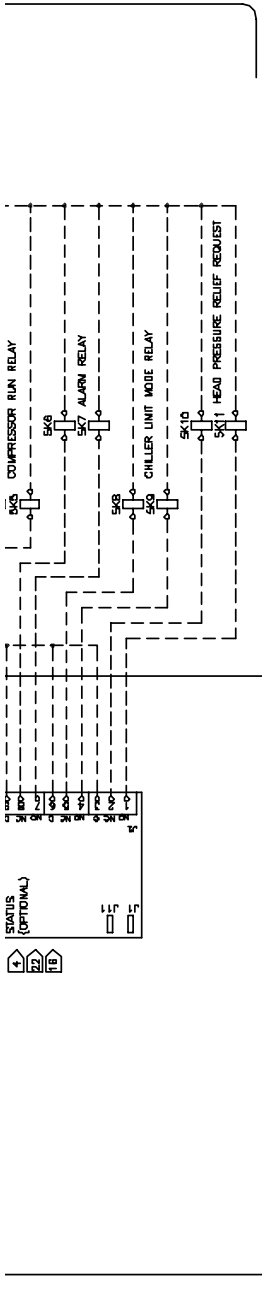

- GENERAL NOTES**
- CAUTION—DO NOT ENERGIZE THE UNIT UNTIL CHECK OUT AND STARTUP PROCEDURES HAVE BEEN COMPLETED.
  - COMPRESSOR MOTOR IS PROTECTED FROM PRIMARY SINGLE PHASE FAILURE.
  - ALL UNIT POWER WIRING MUST BE COPPER CONDUCTORS ONLY AND HAVE A MINIMUM TEMPERATURE INSULATION RATING OF 75 DEGREE C (WIRA = 0-598) OR 90 DEGREE C (WIRA = 778). SEE UNIT NAMEPLATE FOR MINIMUM CIRCUIT AMPACITY AND MINIMUM FUSE SIZE REQUIREMENTS. USE 600 VOLT COPPER CONDUCTORS ONLY, 200 TO 600 VOLT CIRCUIT. PROVIDE AN EQUIPMENT GROUND IN ACCORDANCE WITH APPLICABLE ELECTRIC CODES.
  - THESE FEATURES ARE OPTIONAL AND MAY NOT BE PROVIDED. CUSTOMER PROVIDED WIRING FOR ALL STANDARD FEATURES AND OPTIONS IS SHOWN ON THIS DIAGRAM. OPTIONAL FEATURES ARE SO NOTED.
  - OPENING THE EXTERNAL AUTO-STOP CONTACT WILL INITIATE A SHUT DOWN SEQUENCE OF THE CHILLER. CLOSURE OF THE CONTACT WILL ALLOW THE CHILLER TO RETURN TO NORMAL AUTOMATIC OPERATION.
  - AN OPENING OF THE EMERGENCY STOP CONTACT WILL SHUT THE CHILLER DOWN IMMEDIATELY AND TRIGGER AN EMERGENCY STOP CHILLER PROTECTION. CLOSURE OF THE CONTACT AND A MANUAL RESET OF THE UNIT CONTROL UNIDIRECTIONAL WILL ALLOW THE CHILLER TO RETURN TO NORMAL AUTOMATIC OPERATION.
  - ICE BUILDUP CONTROL IS OPTIONAL. THE 120 MODULE IS STANDARD FOR A SOLID STATE STARTER UNIT BUT IS OPTIONAL FOR A WYE-DELTA STARTER.
- WIRING REQUIREMENTS**
- RECOMMENDED FIELD WIRING CONNECTIONS ARE SHOWN BY DASHED LINES
  - ALL FIELD WIRING MUST BE IN ACCORDANCE WITH THE NATIONAL ELECTRIC CODE AND STATE AND LOCAL REQUIREMENTS.
  - EXCEPT UNIT WIRING VALUES BLOCK, DISCONNECT OR HACR CIRCUIT BREAKER. THE POWER WIRING LUG SIZE PROVIDED ON THE VARIOUS UNITS IS SHOWN IN TABLE 1.
  - LINE VOLTAGE OPTIONS:
  - CLASS 1 WIRING: 14 AWG, 800 VOLT CONDUCTORS, 115 VOLT CIRCUIT
  - ALL CUSTOMER CONTROL CIRCUIT WIRING MUST BE COPPER CONDUCTORS ONLY AND HAVE A MINIMUM INSULATION RATING OF 300 VOLTS EXCEPT AS NOTED. ALL CUSTOMER WIRING CONNECTIONS ARE MADE TO CIRCUIT BOARD MOUNTED BOX LUGS WITH A WIRE RANGE OF 14 TO 18 AWG.
  - DO NOT RUN LOW VOLTAGE CONTROL WIRING (50 VOLTS OR LESS) IN CONDUIT WITH 110 VOLT OR HIGHER WIRING. DO NOT EXCEED THE FOLLOWING MAXIMUM RUN LENGTHS FOR A GIVEN SIZE: 14 AWG, 5000 FT; 16 AWG, 2000 FT; 18 AWG, 1000 FT.
  - FRAME TRACER SHIELDING IS NOT RECOMMENDED.
  - FRAME IS SHIELDED TWISTED PAIR COMMUNICATION CABLE 14-18 AWG, 600V DABLE, 30 VOLT CIRCUIT. THE SUM TOTAL LENGTH OF ALL INTERCONNECTED CABLE SEGMENTS NOT TO EXCEED 6000 FEET. AROUND THE SHIELD AT THE TRACER END ONLY. REFER TO THE IOM FOR COMPLETE CABLE AND INSTALLATION REQUIREMENTS. FRAME TRACER SUMMIT MAY ALSO USE LSI WIRING RECOMMENDED BELOW.
  - CONNECTIONS TO COMMUNICATION INTERFACES (LIS) RECOMMENDED WIRE
  - UNSHIELDED COMMUNICATION WIRE RECOMMENDED. THE SUM TOTAL LENGTH OF ALL INTERCONNECTED CABLE SEGMENTS NOT TO EXCEED 6000 FEET. CONNECTIONS TO COMMUNICATION INTERFACES SHOULD BE DASH CHANNEL. REFER TO BELONGING AUTOMATION SYSTEM (BAS) COMMUNICATION INSTALLATION LITERATURE FOR END OF LINE TERMINATION RESISTOR REQUIREMENTS.

- THE CONTRACTS FOR THESE FEATURES ARE JAMPPERED AT THE FACTORY BY JUMPPERS W1 & W2 TO ENABLE UNIT OPERATION. IF REMOTE CONTROL IS DESIRED REMOVE THE JUMPPERS AND CONNECT TO THE DESIRED CONTROL CIRCUIT.
  - FIELD PROVIDED 115 VOLT 60HZ OR 220 VOLT 60HZ CONTROL POWER SUPPLIES ARE REQUIRED. THE MAX FUSE SIZE FOR ALL FIELD PROVIDED WIRING IS 15 AMPS. GROUND ALL CUSTOMER PROVIDED POWER SUPPLIES AS REQUIRED BY CODE. GREEN GROUND SCREWS ARE PROVIDED IN UNIT CONTROL PANEL.
  - CHILLED/CONDENSER WATER PUMP STARTER AUXILIARY CONTACTS TO BE WIRED IN SERIES WITH FLOW SWITCHES.
  - WHEN ORDERED THE OUTDOOR AIR TEMP SENSOR ELECTRONICS IS FACTORY MOUNTED INSIDE THE CONTROL PANEL AND THE PC BUS IS FACTORY WIRED. THE SENSOR IS TO BE FIELD WIRING EXTERNALLY WITH THE SENSOR LEADS EXTENDED BACK TO THE CONTROL PANEL. THESE WIRES CAN BE SPliced WITH TWO 14-18 AND 600V WIRES WITH A MAXIMUM LENGTH OF 1000 FEET (300 METERS). SPlice AT SENSOR END MUST BE WATER TIGHT. REFER TO UNIT IOM FOR DETAILS.
- CONTACT RATINGS AND REQUIREMENTS**
- UNIT PROVIDED DRY CONTACTS FOR THE CONDENSER/CHILLED WATER FLOW CONTROL. THE UNIT OPERATING STATUS RELAYS AND ICE MAKING STATUS RELAY ARE RATED FOR 7.5 AMPS RESISTIVE, 2400 AMPS PLUG DUTY, DR 1/3 HP, 7.2 FLA AT 120 VOLTS 60 H.Z. CONTACTS ARE RATED FOR 5 AMPS GENERAL PURPOSE DUTY AT 240 VOLTS.
  - CUSTOMER SUPPLIED CONTACTS FOR ALL LOW VOLTAGE CONNECTIONS MUST BE COMPATIBLE WITH DRY CIRCUIT 24 VOLTS DC FOR A 12 MA RESISTIVE LOAD. SILVER OR GOLD PLATED CONTACTS ARE RECOMMENDED.
  - FLOW SWITCH AND INTERLOCK CONTACTS MUST BE ACCEPTABLE FOR USE IN A 120 VOLT 1ma CIRCUIT. OR A 220 VOLT 2ma CIRCUIT.
  - THE FIELD PROVIDED INDICATORS MAY BE RELAYS, LIGHTS OR AUDIBLE BELLERS. EACH INDICATOR IS ASSOCIATED WITH A SPST RELAY. THE INDICATOR FUNCTIONS MAY BE CONNECTED TO EITHER OR BOTH OF THE NORMALLY OPEN OR NORMALLY CLOSED RELAY CONTACTS OF EACH OF THE 4 SPST RELAYS ON THE OPTIONAL UNIT OPERATING STATUS MODULE.
  - THE FUNCTIONS OF THE OPERATING STATUS MODULE RELAYS ARE PROGRAMMABLE. SEE IOM FOR DETAILS. DEFAULT FUNCTIONS ARE SHOWN. THE NORMALLY OPEN CONTACTS ON EACH RELAY OPERATE AS FOLLOWS:
- COMPRESSOR — THE NO CONTACTS CLOSE WHEN COMPRESSOR STATUS FROM STARTER MODULE IS EITHER STARTING OR RUNNING
- ALARM RELAY — THE NO CONTACTS CLOSE WHEN THERE IS A DIAGNOSTIC THAT HAS CAUSED A CHILLER SHUTDOWN WITH EITHER A MANUAL RESET REQUIRED OR AN AUTOMATIC RESET POTENTIAL.

CHILLER LIMIT — THE NO CONTACTS CLOSE WHENEVER THE CHILLER HAS BEEN RUNNING IN ONE OF THE FOLLOWING TYPES OF VALUE RELAY

HEAD PRESSURE RELIEF REQUEST — THE NO CONTACTS CLOSE ANYTIME THE CHILLER IS RUNNING IN ONE OF THE FOLLOWING MODES: ICE MAKING MODE OR CONDENSER PRESSURE UNIT CONTROL. MODE CONTINUOUSLY FOR THE DURATION SPECIFIED BY THE CHILLER HEAD RELIEF RELAY FILTER TIME.

- FIELD SELECTABLE AS: CONDENSER PRESSURE, DELTA PRESSURE OR CONTROL OUTPUT SIGNAL FOR CONDENSER HEAD PRESSURE CONTROL.
- THE FIELD WIRING FOR THE 119V HOT LEG IS TERMINATED TO THE TERMINAL BLOCK. SEE INSTRUCTION LABEL IN CONTROL PANEL FOR WIRE INSERTION INSTRUCTIONS. SHLDC FIELD WIRES TOGETHER AND WIRE TO 1M6.
- CLOSED CONTACT COMMANDS BASE LOADING OPERATION.
- ACTUAL BASE LOADING BETPOINT USED IS DETEMABLE AT FRONT PANEL. REFER TO IOM FOR DETAILS.

**NOTES**

1. DASHED LINES INDICATE FIELD WIRING BY OTHERS. PHANTOM LINES INDICATE ALTERNATE CIRCUITRY OR AVAILABLE SALES OPTIONS. CHECK SALES ORDER TO DETERMINE IF WIRING IS REQUIRED FOR SPECIFIC OPTIONS.
2. REQUIRED DEVICE AND/OR CIRCUITRY BY OTHERS.
3. REQUIRED DEVICE AVAILABLE FROM TRANE. FIELD INSTALLED.
4. OPENING THE EXTERNAL AUTO-STOP CONTACT WILL INITIATE A SHUT DOWN SEQUENCE OF THE CHILLER. CLOSURE OF THE CONTACT WILL ALLOW THE CHILLER TO RETURN TO NORMAL AUTOMATIC OPERATION.
8. AN OPENING OF THE EMERGENCY STOP CONTACT WILL SHUT THE CHILLER DOWN IMMEDIATELY AND TRIGGER AN EMERGENCY STOP INPUT DIAGNOSTIC. CLOSURE OF THE CONTACT AND A MANUAL RESET OF THE UNIT CONTROL DIAGNOSTIC WILL ALLOW THE CHILLER TO RETURN TO NORMAL OPERATION.

**GENERAL WIRING REQUIREMENTS AND PROVISIONS**

8. THE EIGHT 1/2" CONDUIT KNOCKOUTS LOCATED NEAR THE TOP OF THE RIGHT HAND SIDE OF THE CONTROL PANEL ARE FOR USE WITH LOW VOLTAGE 30 VOLT CIRCUIT WIRING.
7. THE SIX 1/2" CONDUIT KNOCKOUTS AND 4 1-1/4" KNOCKOUTS LOCATED NEAR THE BOTTOM OF THE RIGHT HAND SIDE OF THE CONTROL PANEL ARE FOR USE WITH 115 VOLT CIRCUIT WIRING.

**REQUIRED WIRING:**

8. CLASS 1 WIRING: 14 AWG, 600 VOLT CONDUCTORS, 115 VOLT CIRCUIT
9. CLASS 2 WIRING.

**TRANE TRACER SUMMIT RECOMMENDED WIRE:**

TRANE KCS SHIELDED TWISTED PAIR COMMUNICATION CABLE 14-18 AWG, 800V DAILE, 30 VOLT CIRCUIT. THE SUM TOTAL LENGTH OF ALL INTERCONNECTED CABLE SEGMENTS NOT TO EXCEED 4500 FEET. CONNECTION TOPOLOGY SHOULD BE DMSY CHAIN. REFER TO BUILDING AUTOMATION SYSTEM (BAS) COMMUNICATION INSTALLATION LITERATURE FOR END OF LINE TERMINATION RESISTOR REQUIREMENTS.

LONTALK COMMUNICATION INTERFACE (LCI) RECOMMENDED WIRE: 22 AWG LEVEL 4 UNSHIELDED COMMUNICATION WIRE RECOMMENDED. THE SUM TOTAL LENGTH OF ALL INTERCONNECTED CABLE SEGMENTS NOT TO EXCEED 4500 FEET. CONNECTION TOPOLOGY SHOULD BE DMSY CHAIN. REFER TO BUILDING AUTOMATION SYSTEM (BAS) COMMUNICATION INSTALLATION LITERATURE FOR END OF LINE TERMINATION RESISTOR REQUIREMENTS.

11. THE FIELD WIRING FOR THE 115V HOT LEG IS TERMINATED TO 1X8 TERMINAL BLOCK. SEE INSTRUCTION LABEL IN CONTROL PANEL FOR WIRE INSERTION INSTRUCTIONS. SPLICE FIELD WIRES TOGETHER AND WIRE TO 1X8.

**GENERAL NOTES:**

12. CAUTION-DO NOT ENERGIZE THE UNIT UNTIL CHECK OUT AND STARTUP PROCEDURES HAVE BEEN COMPLETED.
13. COMPRESSOR MOTOR IS PROTECTED FROM PRIMARY SINGLE PHASE FAILURE.
14. THESE FEATURES ARE OPTIONAL AND MAY OR MAY NOT BE PROVIDED. CUSTOMER PROVIDED WIRING FOR ALL STANDARD FEATURES AND OPTIONS IS SHOWN ON THIS DIAGRAM. OPTIONAL FEATURES ARE SO NOTED.

**WIRING REQUIREMENTS**

15. ALL FIELD WIRING MUST BE IN ACCORDANCE WITH THE NATIONAL ELECTRIC CODE AND STATE AND LOCAL REQUIREMENTS. EXPORT UNIT WIRING MUST COMPLY WITH LOCAL APPLICABLE CODES.
16. ALL UNIT POWER WIRING MUST BE COPPER CONDUCTORS ONLY AND HAVE A MINIMUM TEMPERATURE INSULATION RATING OF 75 DEGREE C. SEE UNIT NAMEPLATE FOR MINIMUM CIRCUIT AMPACITY AND MAXIMUM FUSE SIZE REQUIREMENTS. USE 800 VOLT COPPER CONDUCTORS ONLY, 200 TO 600 VOLT CIRCUIT. PROVIDE AN EQUIPMENT GROUND IN ACCORDANCE WITH APPLICABLE ELECTRIC CODES.
17. LINE VOLTAGE OPTIONS:  
UNIT MOUNTED TERMINAL BLOCK, DISCONNECT OR HACR CIRCUIT BREAKER THE POWER WIRING LUG SIZE PROVIDED ON THE VARIOUS UNITS IS SHOWN IN TABLE 2.
18. ALL CUSTOMER CONTROL CIRCUIT WIRING MUST BE COPPER CONDUCTORS ONLY AND HAVE A MINIMUM INSULATION RATING OF 300 VOLTS. EXCEPT AS NOTED ALL CUSTOMER WIRING CONNECTIONS ARE MADE TO CIRCUIT BOARD MOUNTED BOX LUGS WITH A WIRE RANGE OF 14 TO 18 AWG.

19. FIELD SELECTABLE AS: CONDENSER PRESSURE, DELTA PRESSURE OR CONTROL OUTPUT SIGNAL FOR CONDENSER HEAD PRESSURE CONTROL.
20. DO NOT RUN LOW VOLTAGE CONTROL WIRING (30 VOLTS OR LESS) IN CONDUIT WITH 110 VOLT OR HIGHER WIRING. DO NOT EXCEED THE FOLLOWING MAXIMUM RUN LENGTHS FOR A GIVEN SIZE: 14 AWG, 5000 FT; 18 AWG, 2000 FT; 18 AWG, 1000 FT.
21. THE CONTACTS FOR THESE FEATURES ARE JUMPERED AT THE FACTORY BY JUMPERS W1 & W2 TO ENABLE UNIT OPERATION. IF REMOTE CONTROL IS DESIRED REMOVE THE NOTED JUMPERS AND CONNECT TO THE DESIRED CONTROL CIRCUIT.
22. FIELD PROVIDED 115 VOLT 60HZ OR 220 VOLT 50HZ CONTROL POWER SUPPLIES ARE REQUIRED. THE MAX FUSE SIZE FOR ALL FIELD PROVIDED WIRING IS 10 AMPS. GROUND ALL CUSTOMER PROVIDED POWER SUPPLIES AS REQUIRED BY CODE. GREEN GROUND SCREWS ARE PROVIDED IN UNIT CONTROL PANEL.
23. CLOSED CONTACT COMMANDS BASE LOADING OPERATION.
24. ACTUAL BASE LOADING SETPOINT USED IS SETABLE AT FRONT PANEL. REFER TO IOM FOR DETAILS.

**CONTACT RATINGS AND REQUIREMENTS**

25. UNIT PROVIDED DRY CONTACTS FOR THE CONDENSER/CHILLED WATER PUMP CONTROL. THE UNIT OPERATING STATUS RELAYS AND ICE MAKING STATUS RELAY ARE RATED FOR 7.2 AMPS RESISTIVE, 2.88 AMPS FLUIT DUTY, OR 1/3 HP, 7.2 FLA AT 120 VOLTS 60 HZ. CONTACTS ARE RATED FOR 5 AMPS GENERAL PURPOSE DUTY AT 240 VOLTS.
26. CUSTOMER SUPPLIED CONTACTS FOR ALL CLASS 2 CONNECTIONS MUST BE COMPATIBLE WITH THE CIRCUIT 25 VOLTS DC FOR A 1.2 MA RESISTIVE LOAD. SILVER OR GOLD PLATED CONTACTS ARE RECOMMENDED.
27. FLOW SWITCH & INTERLOCK CONTACTS MUST BE ACCEPTABLE FOR USE IN A 120 VOLT 1 mA CIRCUIT OR A 230 VOLT 2 mA CIRCUIT.
28. CHILLED / CONDENSER WATER PUMP STARTER AUXILIARY CONTACTS TO BE WIRING IN SERIES WITH FLOW SWITCHES.

29. THE FIELD PROVIDED INDICATORS MAY BE RELAYS, LIGHTS OR AUDIBLE DEVICES. EACH FUNCTION IS ASSOCIATED WITH A SPOT RELAY. THE INDICATORS MAY BE CONNECTED TO EITHER OR BOTH OF THE NORMALLY OPEN OR NORMALLY CLOSED RELAY CONTACTS OF EACH OF THE 4 SPOT RELAYS ON THE OPTIONAL UNIT OPERATING STATUS MODULE. THE FUNCTIONS OF THE OPERATING STATUS MODULE RELAYS ARE PROGRAMMABLE. SEE IOM FOR DETAILS. DEFAULT FUNCTIONS ARE SHOWN.  
THE NORMALLY OPEN CONTACTS ON EACH RELAY OPERATE AS FOLLOWS:  
COMPRESSOR RUNNING — THE NO CONTACTS CLOSE WHEN COMPRESSOR STATUS FROM STARTER MODULE IS EITHER STARTING OR RUNNING.  
ALARM RELAY — THE NO CONTACTS CLOSE WHEN THERE IS AN DIAGNOSTIC THAT HAS CAUSED A CHILLER SHUTDOWN WITH EITHER A MANUAL RESET REQUIRED OR AN AUTOMATIC RESET POTENTIAL.  
CHILLER LIMIT MODE RELAY — THE NO CONTACTS CLOSE WHENEVER THE CHILLER HAS BEEN RUNNING IN ONE OF THE UNLOADING TYPES OF LIMIT MODES (CONDENSER, EVAPORATOR, CURRENT LIMIT OR PHASE IMBALANCE LIMIT) CONTINUOUSLY FOR THE LAST 20 MINUTES.  
HEAD PRESSURE RELIEF REQUEST — THE NO CONTACTS CLOSE ANYTIME THE CHILLER IS RUNNING IN ONE OF THE FOLLOWING MODES: ICE MAKING MODE OR CONDENSER PRESSURE LIMIT CONTROL MODE CONTINUOUSLY FOR THE DURATION SPECIFIED BY THE CHILLER HEAD RELIEF RELAY FILTER TIME.

30. WHEN ORDERED THE OUTDOOR AIR TEMP SENSOR ELECTRONICS IS FACTORY MOUNTED INSIDE THE CONTROL PANEL AND THE IPC BUS IS FACTORY WIRED. THE SENSOR IS TO BE FIELD WIRED, RELOCATED EXTERNALLY WITH THE SENSOR LEADS EXTENDED BACK TO THE CONTROL PANEL. THESE WIRES CAN BE SPLICED WITH TWO 14 - 18 AWG 800V WIRES, WITH A MAXIMUM LENGTH OF 1000 FT (305 METERS). SPLICE AT SENSOR END MUST BE WATER TIGHT. REFER TO UNIT IOM FOR DETAILS.

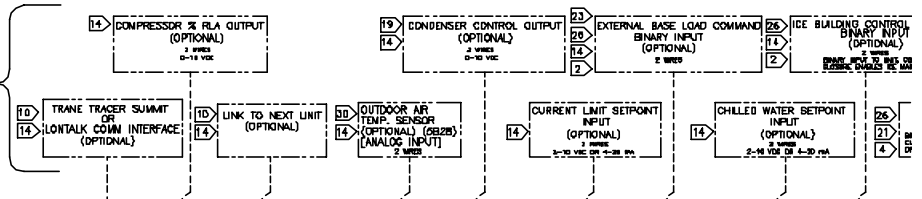

**TABLE 2**

SELECTION FLA	CIRCUIT BREAKER LUG	STARTER SIZE MRLA	NON FUSED DISCONNECT SWITCH LUG
0-478	(2) 3/0-500 MCM	207-478	(2) 3/0-500 MCM
477-640	(3) 1/0-300 MCM	500, 508	(3) 1/0-300 MCM
641-779	(4) 250-300 MCM	778	(4) 250-300 MCM
			MAIN LUGS ONLY
		207-478	(2) 3/0-500 MCM
		500-599	(2) 1/0-300 MCM

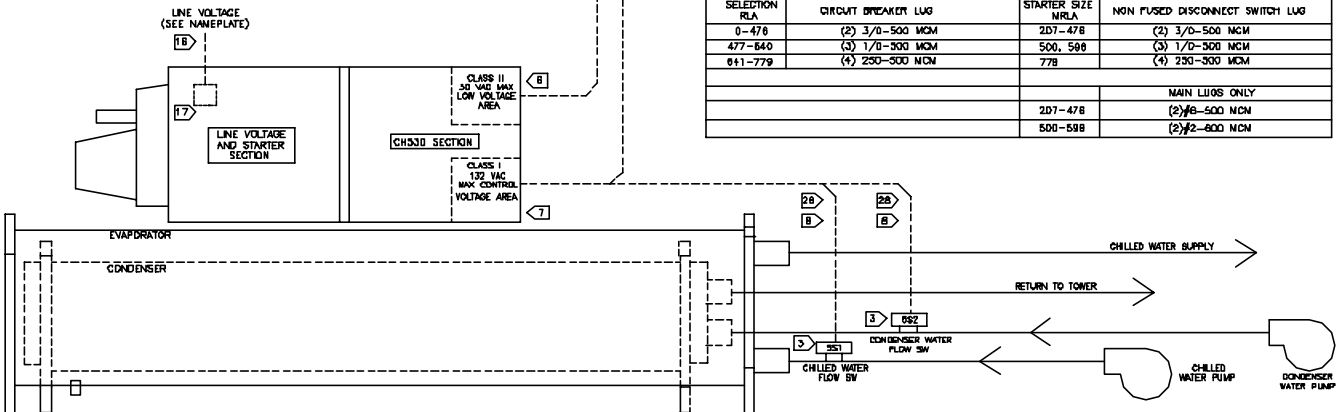

REVISED	2D CAD	FILE NUMBER	DRAWING NUMBER	REV
REVISION DATE	YOUR TRANE COMPANY AMERICAN OVERSEAS, INC. *REVIEW & APPROVE FOR FIELD SERVICE USE ONLY DO NOT REMOVE FROM THIS DRAWING		2309-4869	C
DRAWN BY PBL		RTHD	FIELD LAYOUT DIAGRAM	
DATE 1-21-03	SIMILAR TO			

22 THE FIELD PROVIDED INDICATORS MAY BE RELAYS, LIGHTS OR AUDIBLE DEVICES. EACH FUNCTION IS ASSOCIATED WITH A SPOT RELAY. THE INDICATORS MAY BE CONNECTED TO EITHER OR BOTH OF THE NORMALLY OPEN OR NORMALLY CLOSED RELAY CONTACTS OF EACH OF THE 4 SPOT RELAYS ON THE OPTIONAL UNIT OPERATING STATUS MODULE.

THE FUNCTIONS OF THE OPERATING STATUS MODULE RELAYS ARE PROGRAMMABLE. SEE IOM FOR DETAILS. DEFAULT FUNCTIONS ARE SHOWN. THE NORMALLY OPEN CONTACTS ON EACH RELAY OPERATE AS FOLLOWS:

- COMPRESSOR RUNNING — THE NO CONTACTS CLOSE WHEN COMPRESSOR STATUS FROM STARTER MODULE IS EITHER STARTING OR RUNNING.
- ALARM RELAY — THE NO CONTACTS CLOSE WHEN THERE IS AN DIAGNOSTIC THAT HAS CAUSED A CHILLER SHUTDOWN WITH EITHER A MANUAL RESET REQUIRED OR AN AUTOMATIC RESET POTENTIAL.
- CHILLER LIMIT MODE RELAY — THE NO CONTACTS CLOSE WHENEVER THE CHILLER HAS BEEN RUNNING IN ONE OF THE FOLLOWING TYPES OF LIMIT MODES (CONDENSER, EVAPORATOR, CURRENT LIMIT OR PHASE IMBALANCE LIMIT) CONTINUOUSLY FOR THE LAST 20 MINUTES.
- HEAD PRESSURE RELIEF REQUEST — THE NO CONTACTS CLOSE ANYTIME THE CHILLER IS RUNNING IN ONE OF THE FOLLOWING MODES: ICE MAKING MODE OR CONDENSER PRESSURE LIMIT CONTROL MODE CONTINUOUSLY FOR THE DURATION SPECIFIED BY THE CHILLER HEAD RELIEF RELAY FILTER TIME.

20 WHEN ORDERED THE OUTDOOR AIR TEMP SENSOR ELECTRONICS IS FACTORY MOUNTED INSIDE THE CONTROL PANEL, AND THE IPC BUS IS FACTORY WIRED. THE SENSOR IS TO BE FIELD WIRED, RELOCATED EXTERNALLY WITH THE SENSOR LEADS EXTENDED BACK TO THE CONTROL PANEL. THESE WIRES CAN BE SPliced WITH TWO 14 - 18 AWG BOND WIRES, WITH A MAXIMUM LENGTH OF 1000 FT (305 METERS). SPlice AT SENSOR END MUST BE WATER TIGHT. REFER TO UNIT IOM FOR DETAILS.

**CAUTION**  
USE COPPER CONDUCTORS ONLY!  
UNIT TERMINALS ARE NOT DESIGNED TO ACCEPT OTHER TYPES OF CONDUCTORS.  
FAILURE TO DO SO MAY CAUSE DAMAGE TO THE EQUIPMENT.

**ATTENTION**  
N'UTILISER QUE DES CONDUCTEURS EN CUIVRE!  
LES BORNES DE L'UNITÉ NE SONT PAS CONÇUES POUR RECEVOIR D'AUTRES TYPES DE CONDUCTEURS.  
L'UTILISATION DE TOUT AUTRE CONDUCTEUR PEUT ENDOMMAGER L'EQUIPEMENT.

**PRECAUCIÓN**  
UTILICE ÚNICAMENTE CONDUCTORES DE COBRE!  
LAS TERMINALES DE LA UNIDAD NO ESTÁN DISEÑADAS PARA ACEPTAR OTROS TIPOS DE CONDUCTORES.  
SI NO LO HACE, PUEDE OCASIONAR DAÑO AL EQUIPO.

**WARNING**  
HAZARDOUS VOLTAGE!  
DISCONNECT ALL ELECTRIC POWER INCLUDING REMOTE DISCONNECTS AND FOLLOW LOCK OUT AND TAG PROCEDURES BEFORE SERVICING. INSURE THAT ALL MOTOR CAPACITORS HAVE DISCHARGED STORED VOLTAGE. UNITS WITH VARIABLE SPEED DRIVE, REFER TO DRIVE INSTRUCTIONS FOR CAPACITOR DISCHARGE.  
FAILURE TO DO THE ABOVE BEFORE SERVICING COULD RESULT IN DEATH OR SERIOUS INJURY.

**AVERTISSEMENT**  
TENSION DANGEREUSE!  
COUPER TOUTES LES TENSIONS ET OUVRIRE LES SECTIONNEURS A DISTANCE, PLUS SUIVRE LES PROCEDURES DE VERROUILLAGE ET DES ETIQUETTES AVANT TOUTE INTERVENTION. VERIFIER QUE TOUTS LES CONDENSATEURS DES MOTEURS SONT DECHARGES. DANS LE CAS D'UNITES COMPORTANT DES ENTRAÎNEMENTS A VITESSE VARIABLE, SE REPORTER AUX INSTRUCTIONS DE L'ENTRAÎNEMENT POUR DECHARGER LES CONDENSATEURS.  
NE PAS RESPECTER DES MESURES DE PRECAUTION PEUT ENTRAÎNER DES BLESSURES GRAVES POUVANT ETRE MORTELLES.

**ADVERTENCIA**  
VOLTAJE PELIGROSO!  
DESCONECTE TODA LA ENERGIA ELECTRICA, INCLUIDO LAS DES CONECTORES REMOTOS, Y SIGA LOS PROCEDIMIENTOS DE CIERRE Y ETIQUETADO ANTES DE PROCEDER AL SERVICIO. ASEGURESE DE QUE TODOS LOS CONDENSADORES DEL MOTOR HAYAN DESCARGADO EL VOLTAJE ALMACENADO. PARA LAS UNIDADES CON E.E. DE DIRECCION DE VELOCIDAD VARIABLE, CONSULTE LAS INSTRUCCIONES PARA LA DESCARGA DEL CONDENSADOR.  
EL NO REALIZAR LO ANTERIORMENTE MENCIONADO, PODRIA OCASIONAR LA MUERTE O SERIAS LESIONES PERSONALES.

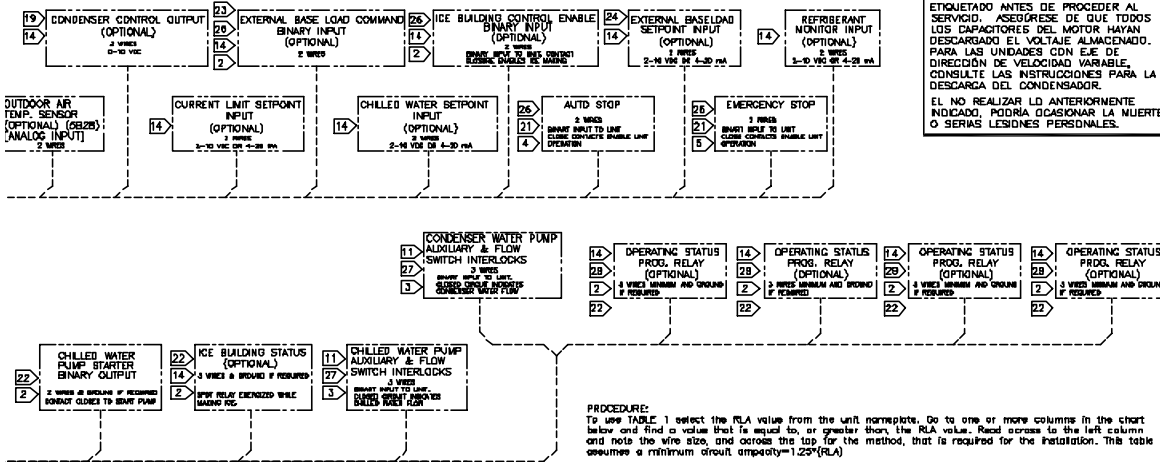

**PROCEDURE:**  
To use TABLE 1 select the RLA value from the unit nameplate. Go to one or more columns in the chart below and find a value that is equal to, or greater than, the RLA value. Read across to the left column and note the wire size, and across the top for the method, that is required for the installation. This table assumes a minimum circuit ampacity=1.25\*(RLA)

**NOTE:**  
This procedure will offer several options for providing electrical service to the starter panel. Before making a final selection, review the accompanying TABLE 2 indicating wire ranges for the available lug sizes shown on the equipment.

**TABLE 2**

BREAKER LUG	STARTER SIZE (MVA)	NON FUSED DISCONNECT SWITCH LUG
3/0-500 MCM	207-478	(2) 3/0-500 MCM
1/0-300 MCM	500, 508	(3) 1/0-300 MCM
250-300 MCM	778	(4) 250-300 MCM
MAIN LUGS ONLY		
	207-478	(2) 3/0-500 MCM
	500-508	(2) 1/0-300 MCM

**TABLE 1**

RECOMMENDED WIRE SELECTION TABLE (REF.2002 NEC)  
RATED LOAD AMPS (RLA)

MIN WIRE SIZE (COPPER) 75°C	SUPPLY LEADS FOR ALL STARTER PANELS							
	1 CONDUIT 3 WIRE	1 CONDUIT 6 WIRE	1 CONDUIT 8 WIRE	2 CONDUIT 4 WIRE	2 CONDUIT 12 WIRE	3 CONDUIT 8 WIRE	4 CONDUIT 12 WIRE	12 WIRE
B	40	**	**	**	**	**	**	**
6	62	**	**	**	**	**	**	**
4	86	**	**	**	**	**	**	**
3	80	**	**	**	**	**	**	**
2	82	**	**	**	**	**	**	**
1	104	**	**	**	**	**	**	**
D	120	192	282	240	384	360	480	
00	140	224	294	290	448	420	510	
000	160	256	336	320	512	480	640	
0000	184	294	368	368	592	552	736	
250	204	328	428	408	652	612	810	
300	228	368	478	458	730	684	912	
350	248	397	521	498	794	744	992	
400	268	428	563	538	858	804	1072	
500	304	498	638	608	972	912	1216	

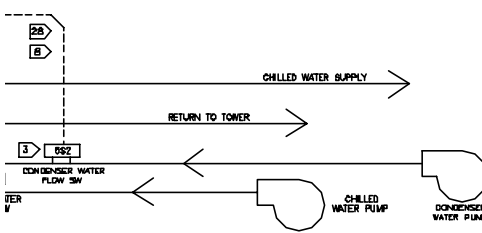

\*\* Electrical conductors may be connected in parallel only for size 1/0 wire and larger per Nec 310-4. The unit nameplate will be marked 'Maximum Fuse or Circuit Breaker Size'. The maximum fuse or circuit breaker size is calculated as follows:  
Calculated value = 2.25 \* (Compressor RLA)  
The calculated value is then used to select the fuse or circuit breaker from the standard sizes.  
Standard Sizes = 100, 110, 125, 150, 175, 200, 225, 300, 350, 400, 450, 500, 600, 700, 800, 1000, 1200, 1600, 2000.  
Maximum Fuse or Circuit Breaker Size = The standard size that is closest to the calculated value without exceeding it.



**Trane**  
A business of American Standard Companies  
[www.trane.com](http://www.trane.com)

For more information contact your local district office or e-mail us at [comfort@trane.com](mailto:comfort@trane.com)

---

Literature Order Number	RTHD-SVX01D-EN
File Number	SV-RF-RTHD-SVX01D-EN-0906
Supersedes	RTHD-SVX01C-EN
Stocking Location	Inland

---

Trane has a policy of continuous product data and product improvement and reserves the right to change design and specifications without notice. Only qualified technicians should perform the installation and servicing of equipment referred to in this bulletin.